

HANGAR 9[®]

Fly First Class™



PT-19 CL

Assembly Manual

Specifications

Wingspan: 54 in (1372mm)
Length: 28.25 in (718mm)
Wing Area: 519 sq in (33.48 sq dm)
Weight: 38-44 oz (1077-1247 g)
Engine:36 CL

Table of Contents

Contents of Kit/Parts Layout.....	2
Important Information Regarding Warranty Information ..	2
UltraCote® Covering Colors	2
Using the Manual.....	3
Before Starting Assembly	3
Power Systems Requirements.....	3
Field Equipment Required.....	3
Optional Field Equipment.....	3
Additional Required Tools and Adhesives	3
Horizontal Stabilizer Installation.....	3
Elevator Installation	6
Vertical Fin Installation.....	8
Wing Installation	9
Elevator Pushrod Installation	10
Tip Weight Installation	12
Landing Gear Installation	13
Engine Installation	15
Connecting the Lines	17
Daily Flight Checks.....	18
Safety Do's and Don'ts for Pilots	19
Safety, Precautions and Warnings	19
Warranty Information.....	19
Instructions for Disposal of WEEE by Users in the European Union	20
2008 Official Academy of Model Aeronautics Safety Code	21
Building and Flying Notes	22

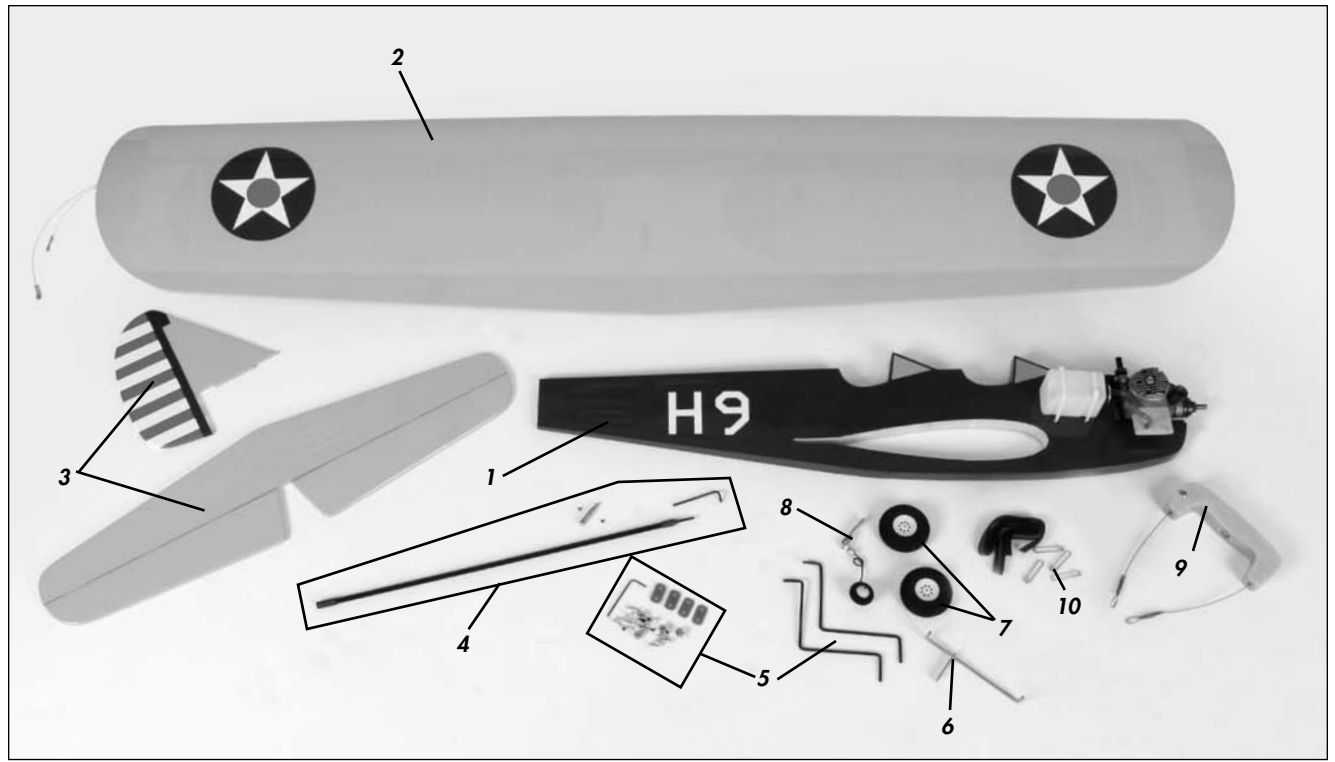

Contents of Kit/Parts Layout

Replacement Parts

- | | | |
|-----|---------|-----------------------------------|
| 1. | HAN0101 | Fuselage w/o Engine |
| 2. | HAN0102 | Main Wing Set |
| 3. | HAN0103 | Tail Set Complete |
| 4. | HAN0104 | Pushrod Assembly |
| 5. | HAN0105 | Landing gear wire and hardware |
| 6. | HAN0106 | Elevator Control Horn |
| 7. | HAN0107 | Main Wheels (2) 2 1/8-inch (54mm) |
| 8. | HAN0108 | Tailwheel Assembly |
| 9. | HAN0109 | Control Line Handle |
| 10. | HAN0111 | Control Line Connectors |

Not Shown

HAN0110 Control Lines (.015 x 60')

Note: Replacement fuselage does not come with engine. The above illustrates version with included engine.

Important Information Regarding Warranty Information

Please read our Warranty and Liability Limitations section on Page 19 before building this product. If you as the Purchaser or user are not prepared to accept the liability associated with the use of this Product, you are advised to return this Product immediately in new and unused condition to the place of purchase.

UltraCote® Covering Colors

- | | |
|--------------|---------|
| • Cub Yellow | HANU884 |
| • True Red | HANU866 |
| • Blue | HANU873 |
| • White | HANU870 |

Using the Manual

This manual is divided into sections to help make assembly easier to understand, and to provide breaks between each major section. In addition, check boxes have been placed next to each step to keep track of each step completed. Steps with a single box (☐) are performed once, while steps with two boxes (☐☐) indicate that the step will require repeating, such as for a right or left wing panel, two servos, etc. Remember to take your time and follow the directions.

Before Starting Assembly

Before beginning the assembly of your PT-19 Trainer, remove each part from its bag for inspection. Closely inspect the fuselage, wing panels, rudder and stabilizer for damage. If you find any damaged or missing parts, contact the place of purchase.

If you find any wrinkles in the covering, use a heat gun or covering iron to remove them. Use caution while working around areas where the colors overlap to prevent separating the colors.



HAN100 – Heat Gun

HAN150 – Covering Glove



HAN101 – Sealing Iron

**HAN141 – Sealing Iron
Sock**

Power Systems Requirements

- Evolution .36 Control Line Engine (EVOE0365)

Field Equipment Required

- Fuel
- Evolution Propeller 10 x 6 2-blade (EVO10060)
- Evolution Propeller 10.5 x 4.5 3-blade (EVOE100P)
- Long Reach Glow Plug Wrench (HAN2510)
- Metered Glow Driver w/Ni-Cd & Charger (HAN7101)
- 2-Cycle Sport Plug (HAN3001)
- 2- and 4-Cycle Super Plug (EVOGP1)
- Manual Fuel Pump (HAN118)

Optional Field Equipment

- Cleaner and towels
- Blue Block After Run Oil (EVOX1000)
- Power Panel (HAN106)
- 12V 7Ah Sealed Battery (HAN102)
- PowerPro 12V Starter (HAN161)
- Micro Digital Tachometer (HAN156)

Additional Required Tools and Adhesives

- 30-minute epoxy
- Adjustable wrench
- Drill
- Felt-tipped pen
- File
- Hex wrench: 3/32-inch
- Hobby knife w/#11 blade
- Mixing sticks
- Mixing cups
- Nut driver: 1/4-inch
- Rubbing alcohol
- Ruler
- Square
- Thin CA
- Threadlock
- Toothpicks
- T-pins
- Weight
- Paper towels
- Drill bit: 1/16-inch (1.5mm)
- Phillips screwdriver: #0, #1

Horizontal Stabilizer Installation

Required Parts

- Stabilizer w/elevators
- Fuselage
- Elevator joiner wire

Required Tools and Adhesives

- Felt-tipped pen
- 30-minute epoxy
- Mixing cups
- Mixing sticks
- Hobby knife w/#11 blade
- Square
- Ruler
- Paper towel
- Rubbing alcohol

☐ Step 1

Use a hobby knife and #11 blade to remove the covering from the slot in the fuselage for the horizontal stabilizer.



□ Step 2

The elevators have been shipped in position on the stabilizer with the hinges. They are not glued and will need to be removed to install the stabilizer in the fuselage.

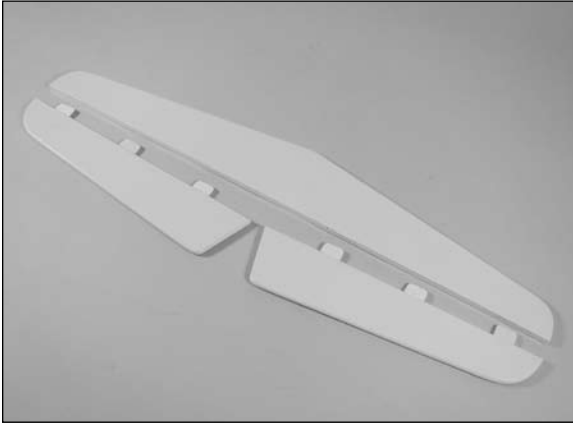

□ Step 3

Locate the notch in the stabilizer that will allow clearance for the control horn in the elevator joiner wire. Use a hobby knife and #11 blade to remove the covering to expose the notch.

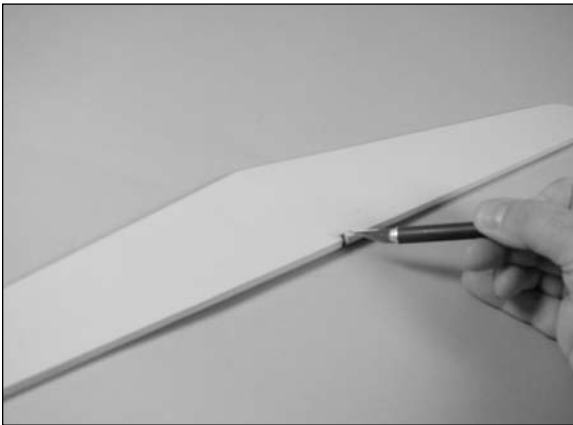

□ Step 4

Slide the stabilizer into the slot in the fuselage. Slide the stabilizer forward as far as possible in the slot. Center the stabilizer (A=A) in the fuselage. Also check the tips of the stabilizer are an equal distance from a point centered at the front of the fuselage (B=B). Make sure the notch in the stabilizer is located on the left side of the fuselage. Left is determined as if you were sitting in the cockpit piloting the aircraft.

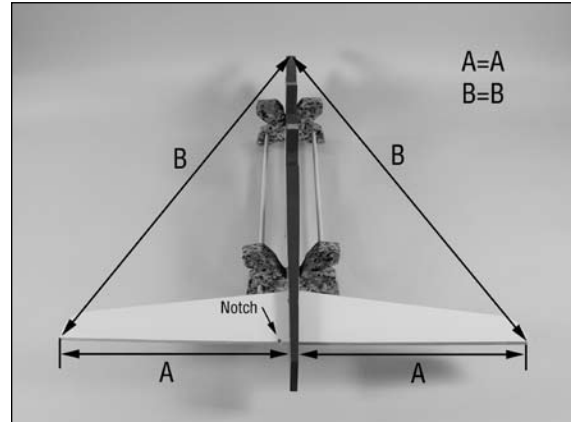

□ Step 5

Once aligned, use a felt-tip pen to trace the outline of the fuselage on the stabilizer. Mark the stabilizer on both the top and bottom, left and right.



□ Step 6

Carefully use a hobby knife to remove the covering 1/16-inch (1.5mm) from inside the lines. Use light pressure with a new #11 blade to avoid cutting into the underlying wood. You will need to trim the covering from the top and bottom of the stabilizer at this time.

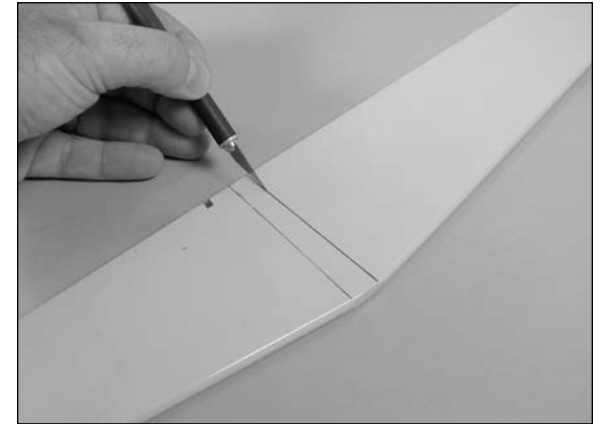

Note: Other options other than a hobby knife are to use a hot knife (with a new blade) or a soldering iron for cutting the covering. These will melt the covering and lower the chances of cutting into the wood structure of the stabilizer.

Hint: Use a paper towel and rubbing alcohol to remove the lines drawn on the stabilizer before gluing the stabilizer into the fuselage.

□ Step 6

Slide the stabilizer back into the fuselage. Check both sides of the stabilizer to make sure it is square with the fuselage. If not, lightly sand the opening in the fuselage for the stabilizer to correct any alignment issues.

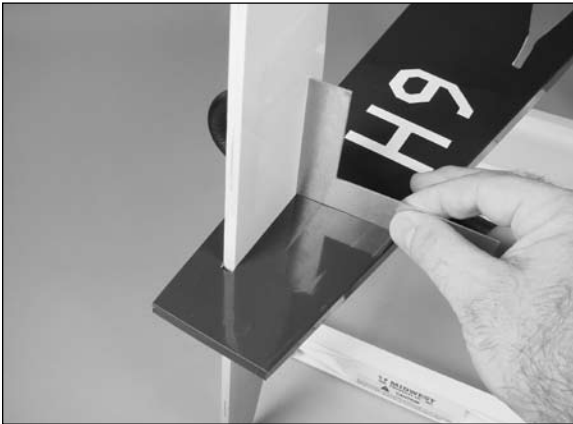
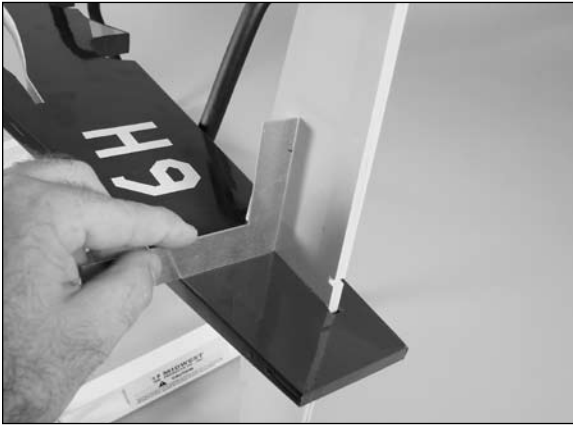

□ Step 7

Slide the stabilizer to the side so the elevator joiner wire can be positioned in the fuselage. Notice that the control horn will align in the slot in the stabilizer.

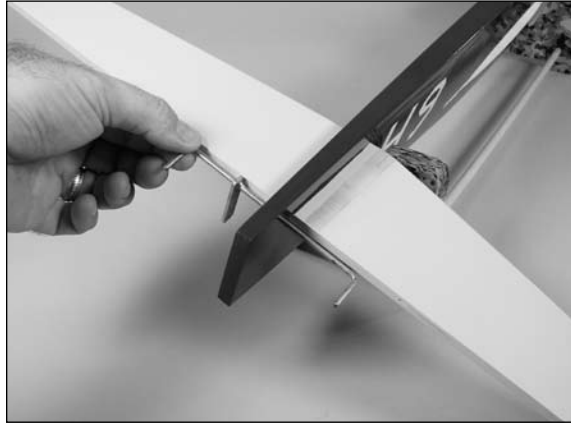

□ Step 8

Mix 1/2 ounce (15ml) of 30-minute epoxy and apply it to the exposed wood on the top and bottom of the stabilizer.



□ Step 9

Slide the stabilizer into position and check its alignment as described in Steps 4 and 6. Use a paper towel and rubbing alcohol to remove any excess epoxy that will ooze from the joint between the fuselage and stabilizer. Allow the epoxy to fully cure before continuing.



Note: If epoxy does not ooze from the joint between the fuselage and stabilizer, you have not used enough epoxy. Go back to Step 8 and apply more epoxy as the stabilizer must be glued securely to the fuselage.

Elevator Installation

Required Parts

- Elevator (right and left)
- Fuselage assembly

Required Tools and Adhesives

- 30-minute epoxy
- Thin CA
- Mixing cups
- Mixing sticks
- Toothpicks
- Hobby knife w/#11 blade
- Paper towel
- Rubbing alcohol
- T-pins

□□ Step 1

Use a hobby knife to remove the covering in the notch and where the elevator joiner wire will fit in the elevator. The elevator with the notch is the left side elevator. Remove the covering in the right elevator for the joiner wire at this time as well.

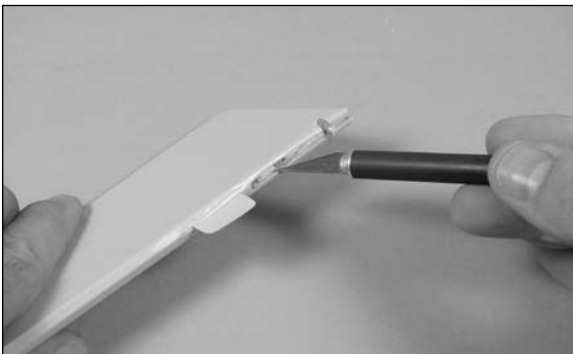
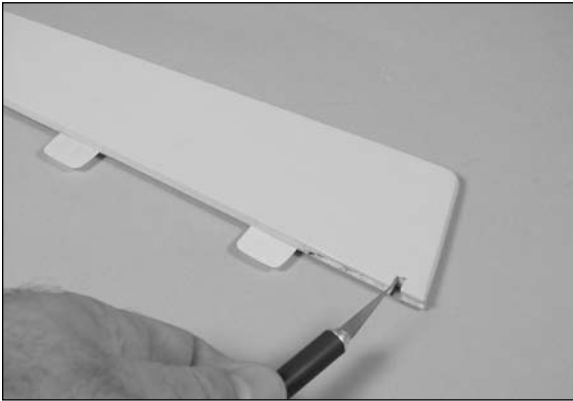

Note: Only one elevator will have the notch that fits the elevator control horn in the joiner wire.

□□ Step 2

Remove the hinges from the elevator. Place a T-pin in the center of each hinge. This will keep them centered equally between the elevator and stabilizer when they are installed.

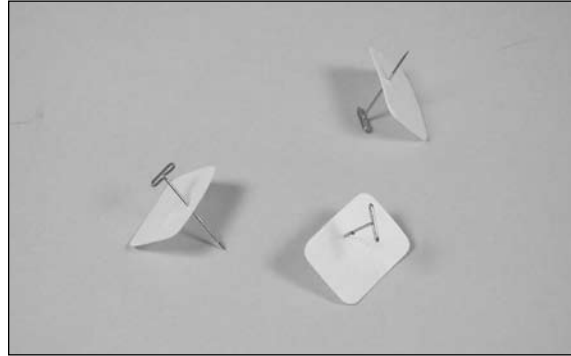

□□ Step 3

Slide the hinges back into the elevator.

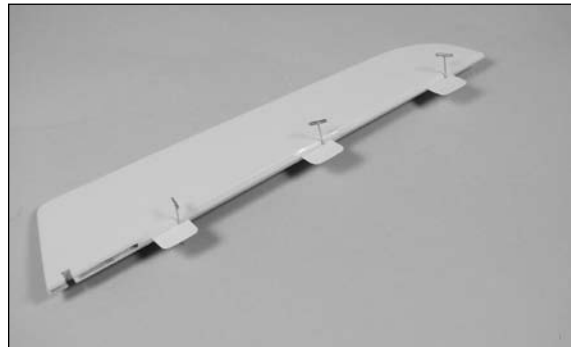
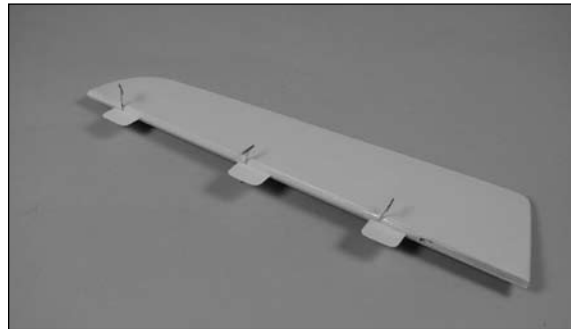

□□ Step 4

Test fit the elevator to the stabilizer by sliding the hinges from the elevator in the stabilizer. Don't forget to insert the joiner wire into the elevator as well. The elevator will rest tight against the stabilizer when installed.



□□ Step 5

Mix a small amount of 30-minute epoxy and apply it to both the elevator joiner wire and the hole in the elevator half the joiner wire fits into. Make sure not to get any epoxy where it could accidentally glue the joiner wire to the stabilizer. Reposition the elevator and make sure the tip of the elevator aligns with the tip of the stabilizer.

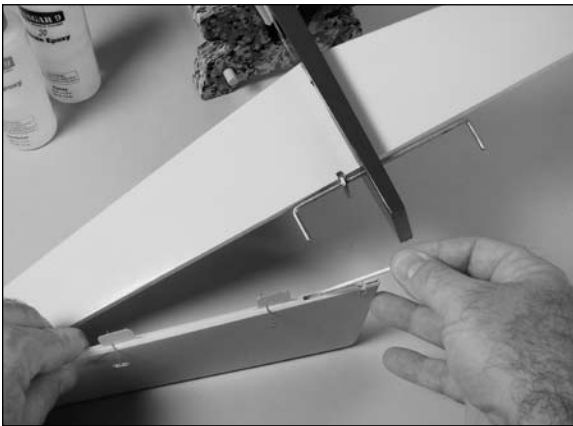

Hint: Use a paper towel and rubbing alcohol to remove any excess epoxy before continuing.

□ Step 6

Repeat Steps 1 through 5 to attach the remaining elevator half to the stabilizer,

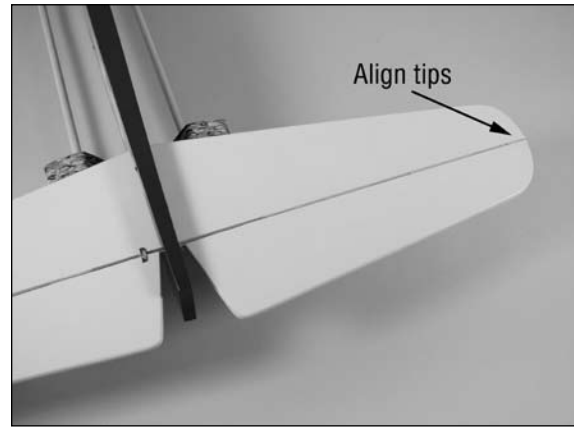

□ Step 7

Remove the T-pins from the hinges. Check to make sure you are able to achieve around 30–45 degrees of deflection for aerobatic flight. Deflect the elevator (don't move it away from the stabilizer) and apply thin CA to the top and bottom of the hinges. Use enough CA so it wicks into the hinge to bond the hinge to the surrounding wood of the stabilizer and elevator. Allow the CA to cure before proceeding.



Note: Do not use a CA accelerator on the hinges. The CA must be allowed to soak into the hinge naturally to provide the best bond between the hinge and surrounding wood.

□ Step 8

Gently attempt to separate the elevator and stabilizer to make sure the hinges are properly glued. If not, apply additional CA to secure loose hinges. Flex the elevator up and down a few times to break-in the hinges to complete the hinging process.



Vertical Fin Installation

Required Parts

- Fuselage assembly
- Vertical fin

Required Tools and Adhesives

- 30-minute epoxy
- Mixing cups
- Toothpicks
- Paper towel
- Mixing sticks
- Hobby knife w/#11 blade
- Rubbing alcohol

Step 1

Use a hobby knife and #11 blade to remove the covering from the top of the fuselage to fit the vertical fin. Also remove the covering from the very aft end of the fuselage leaving 1/16-inch (1.5mm) of covering on each side of the fuselage as shown in the second photo below.



Step 2

Use a hobby knife and #11 blade to remove the covering from the bottom of the fin where it fits into the fuselage. Also remove the covering from the fin where it meets the aft end of the fuselage.

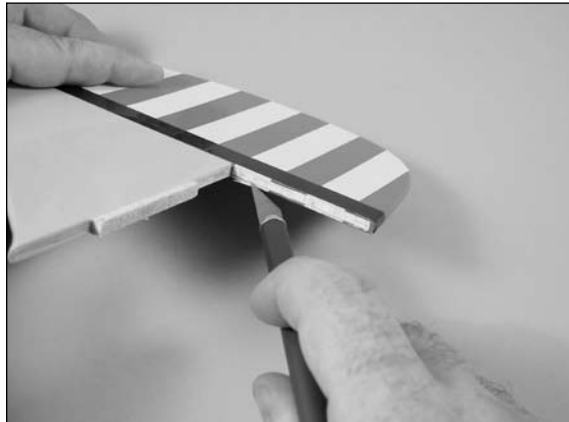
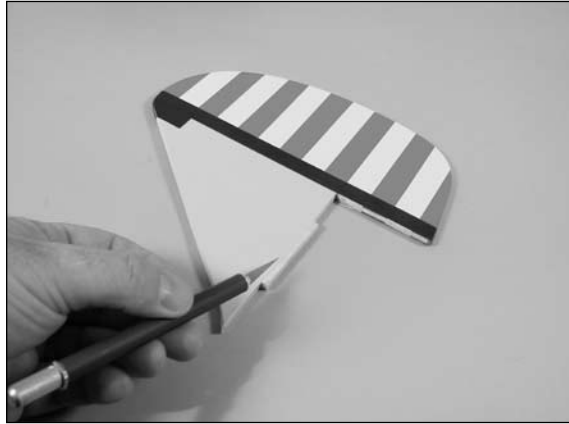

Step 3

Test fit the fin to the fuselage. Use a square to check that the fin fits square to the stabilizer. Use 30-minute epoxy to glue the fin to the fuselage. Apply epoxy to the exposed wood of the fin and fuselage. Allow the epoxy to fully cure before proceeding.



Hint: Use a paper towel and rubbing alcohol to remove any excess epoxy before continuing.

Wing Installation

Required Parts

- Fuselage assembly
- Wing

Required Tools and Adhesives

- 30-minute epoxy
- Mixing cups
- Toothpicks
- Paper towel
- Epoxy brush
- Mixing sticks
- Hobby knife w/#11 blade
- Rubbing alcohol
- Felt-tipped pen

□ Step 1

Slide the wing into the fuselage. Note the opening in the wing for the elevator pushrod is on the top of the wing. Also, the slot for the landing gear will be on the bottom of the wing.



□ Step 2

Slide the wing left and right until the wing is parallel to the stabilizer. This will also center the wing correctly in the fuselage.

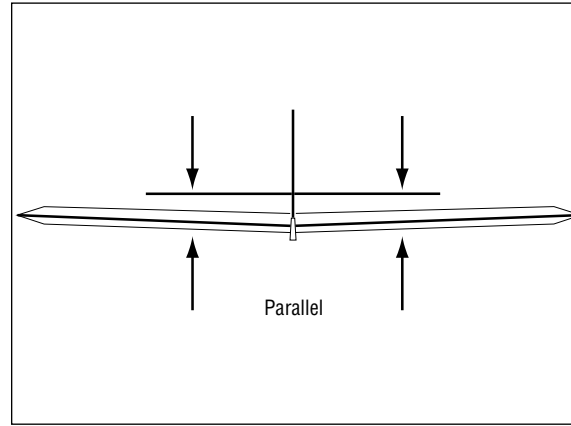

□ Step 3

Use a rule to measure out from the fuselage 21 inches (534mm) from the fuselage on both sides of the wing 3 inches (75mm) back from the leading edge.

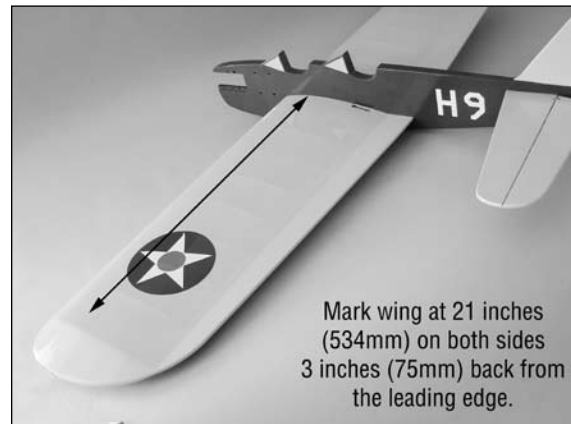

□ Step 4

Use a ruler or string to measure from mark made on the left wing panel to the tip of the stabilizer. Repeat the measurement on the right side and compare the two. They should be identical. If not, reposition the wing and measure it again until both measurements are equal.

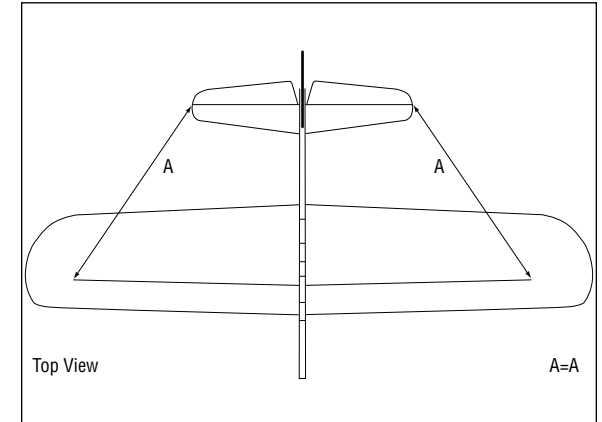

Important: You can not measure from the wing tips to the stabilizer tips as the wing is not equal in length from right to left. Doing so will result in an airframe that is not square and may not fly properly.

□ Step 5

Use a felt-tipped pen to transfer the outline of the fuselage onto the wing, both on the top and bottom.



□ Step 6

Carefully use a hobby knife to remove the covering 1/16-inch (1.5mm) from inside the lines. Use light pressure with a new #11 blade to avoid cutting into the underlying wood. You will need to trim the covering from the top and bottom of the wing at this time.

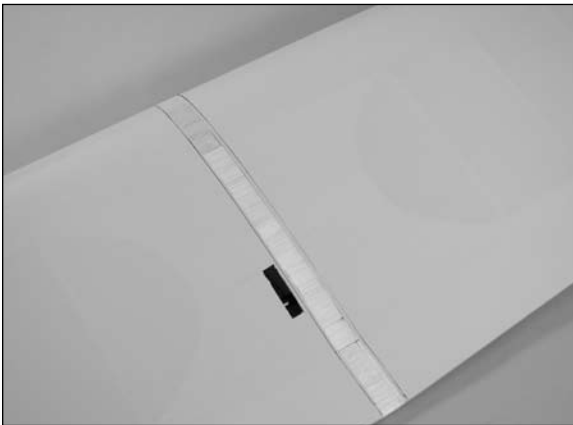
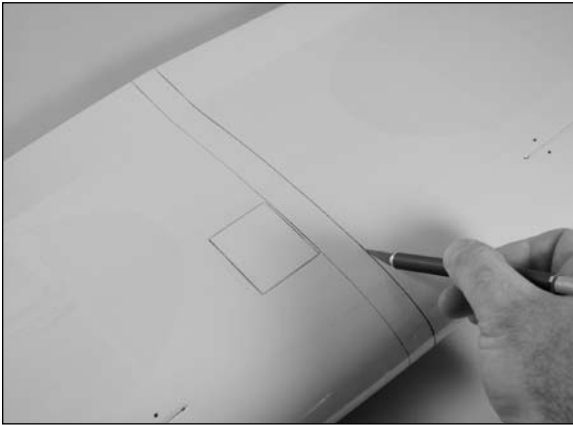

Note: Other options other than a hobby knife are to use a hot knife (with a new blade) or a soldering iron for cutting the covering. These will melt the covering and lower the chances of cutting into the wood structure of the wing.

Hint: Use a paper towel and rubbing alcohol to remove the lines drawn on the wing before gluing to the fuselage.

□ Step 7

Slide the wing in the fuselage. Leave the wing slightly askew so the exposed wood can be accessed.

□ Step 8

Mix 1/2 ounce (15ml) of 30-minute epoxy and apply it to the exposed wood on the top and bottom of the wing. Slide the wing into position and double-check the alignment as described in Steps 2 and 4. Allow the epoxy to fully cure before proceeding.



Note: If epoxy does not ooze from the joint between the fuselage and wing, you have not used enough epoxy. Go back and apply more epoxy as the wing must be glued securely to the fuselage.

Hint: Use a paper towel and rubbing alcohol to remove any excess epoxy before continuing.

Elevator Pushrod Installation

Required Parts

- Assembled airframe
- Carbon elevator pushrod
- Wire pushrod end
- 3mm nut
- Metal clevis
- 3mm setscrew (2)
- 2mm x 10mm sheet metal screw (4)

Required Tools and Adhesives

- Drill
- Threadlock
- Phillips screwdriver: #0
- Hex wrench (included)
- Drill bit: 1/16-inch (1.5mm)
- File

□ Step 1

Remove the hatch to access the bellcrank inside the wing.

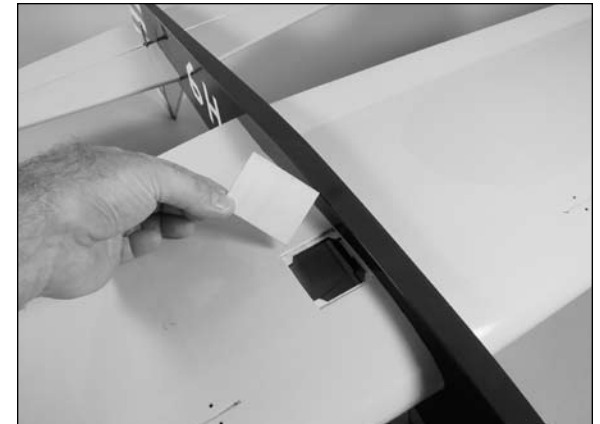

Step 2

Use a file to make a flat spot on opposite sides of the wire pushrod end. The pushrod setscrews will rest on these flat areas making a more secure connection between the wire pushrod end and the carbon pushrod.

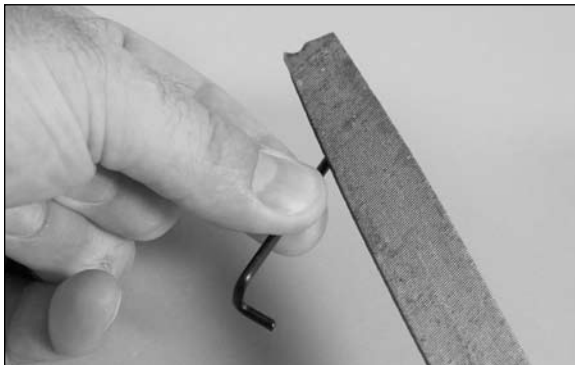
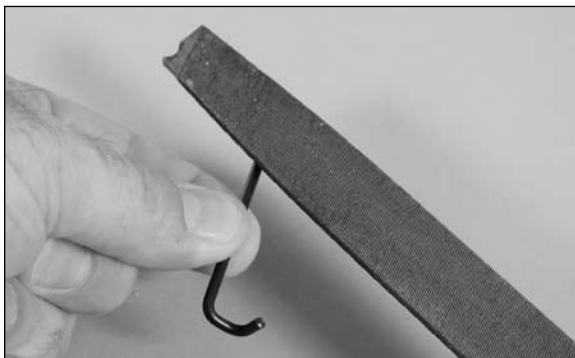

Step 3

Slide the wire pushrod end in the carbon pushrod. Use two 3mm setscrews and the included hex wrench to secure the end in the carbon pushrod.



Important: Make sure to use threadlock on the setscrews to prevent them from vibrating loose.

Step 4

Slide the wire end of the pushrod into the opening in the top of the wing.

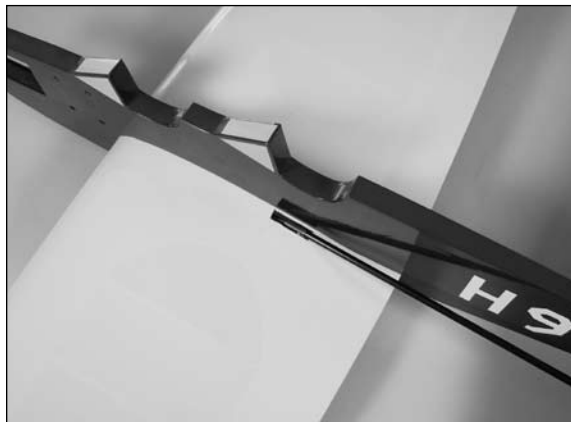

Step 5

Insert the end of the wire into the center hole (or middle) of the bellcrank inside the wing. Rotate the pushrod to completely join the wire to the bellcrank.



Step 6

Thread the 3mm nut onto the threaded fitting of the elevator pushrod. Thread the clevis onto the end at this time as well.



□ Step 7

Attach the clevis to the outside hole on the elevator control horn. Thread the clevis in or out so the elevator is centered when the bellcrank is centered. (See hint below to center the bellcrank.) Once both are aligned, tighten the 3mm nut against the clevis to keep it from vibrating and changing position.



Important: Make sure to use threadlock on the locking nut to prevent it from vibrating loose.

Hint: Slide the hex wrench through the ends of the leadout wires. Lightly pulling on the wrench will bring the bellcrank to the center position.



□ Step 8

Place the bellcrank hatch back in position on the bottom of the wing. Use a drill and 1/16-inch (1.5mm) drill bit to drill four holes in the corners of the bellcrank hatch. Use a #0 Phillips screwdriver and four 2mm x 10mm sheet metal screws to secure the hatch to the fuselage.



Tip Weight Installation

Required Parts

- Assembled airframe
- 2mm x 10mm sheet metal screw

Required Tools and Adhesives

- Drill
- Weight
- Phillips screwdriver: #0
- Paper towel
- Drill bit: 1/16-inch (1.5mm)

□ Step 1

Use a drill and 1/16-inch (1.5mm) drill bit to drill a hole through the pre-drilled hole in the tip weight hatch and into the wing. Use care not to drill through the top of the wing.

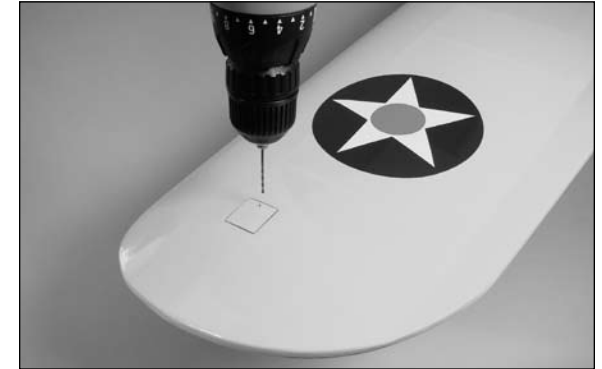

□ Step 2

Insert a 1/2 ounce (14 g) weight into the tip weight box to start. You can adjust the amount of weight later depending on your particular flying style, but we have found this to be a very good starting point.

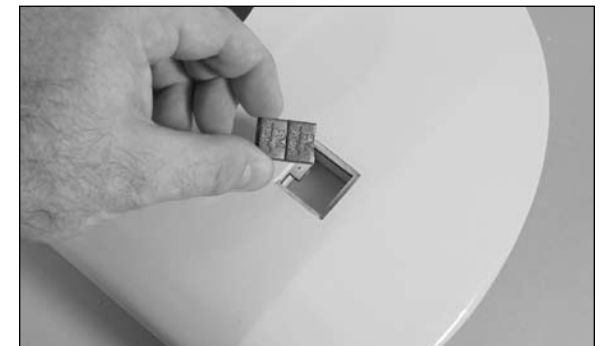

□ Step 3

Insert a small amount of paper towel into the tip weight box to keep the weight from moving around. If it does move, it could damage the weight box and possibly enter the main part of the wing or wing tip.



□ Step 4

Use a #0 Phillips screwdriver and 2mm x 10mm sheet metal screw to secure the tip weight hatch to the wing.



Landing Gear Installation

Required Parts

- Assembled airframe
- Landing gear strap (4)
- Tail wheel assembly
- 1/8-inch wheel collar (4)
- 3mm setscrew (4)
- #4 x 3/4-inch sheet metal screw (8)
- #2 x 1/2-inch sheet metal screw (2)
- 2 1/2-inch (54mm) main wheel (2)
- Main landing gear wire (right and left)

Required Tools and Adhesives

- 30-minute epoxy
- Mixing cups
- Mixing sticks
- Phillips screwdriver: #1
- Hobby knife w/#11 blade
- Hex wrench (included)
- Toothpicks
- Thin CA
- File

□□ Step 1

Use a hobby knife and #11 blade to slit the covering on the bottom of the wing for the main landing gear strut.

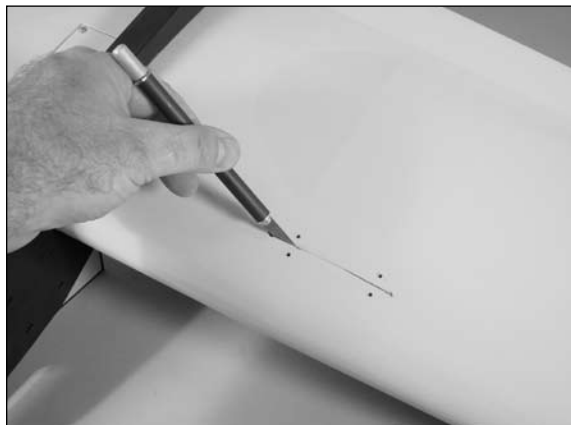

Hint: Use a covering trim iron to seal the edges of the covering down prior to installing the landing gear strut.

□□ Step 2

Locate the main landing gear struts. There is a right and left main gear strut. When installed, they will angle to the front of the aircraft that can be clearly seen in Step 6. Insert the shorter bent end of the strut into the hole in the landing gear block. Press the gear into the block so it is flush with the bottom of the wing.

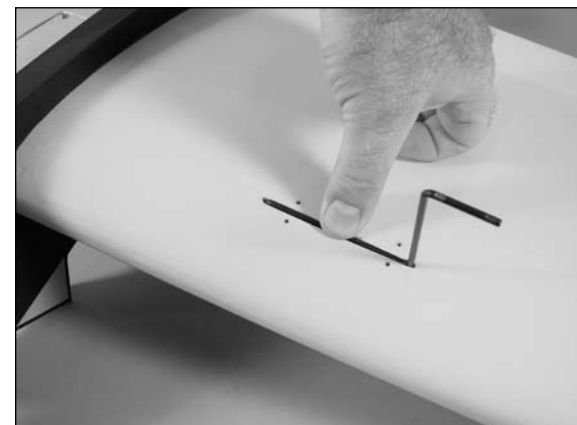
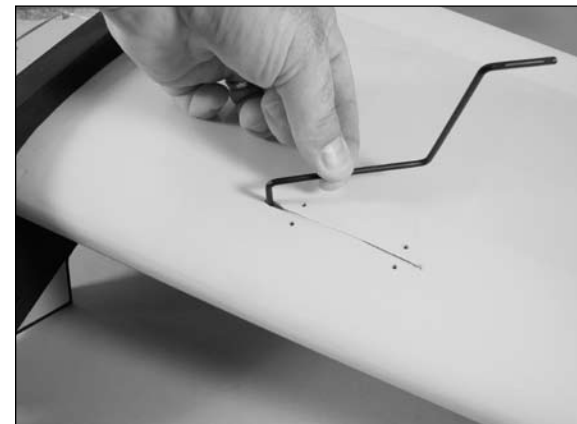

□□ Step 3

Use two landing gear straps and four #4 x 3/4-inch sheet metal screws to secure the main landing gear to the bottom of the wing. Use a #1 Phillips screwdriver to tighten the screws.

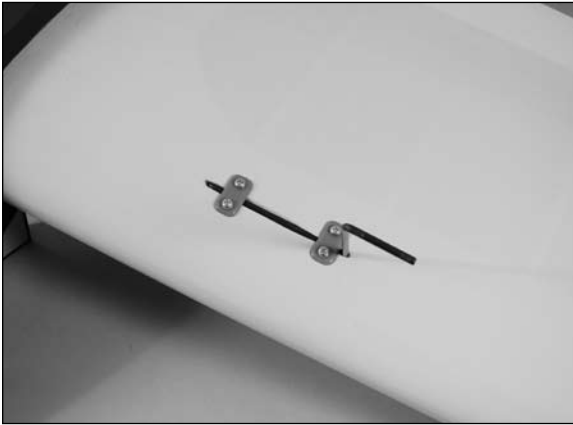

□□ Step 4

Use a file to create a flat area on the main landing gear wire for the setscrews from the wheel collars to rest. This will allow for a more secure attachment of the wheels and help prevent them from falling off in flight.



□□ Step 5

Slide a 1/8-inch wheel collar onto the main gear wire. Use a 3mm setscrew and 1.5mm hex wrench to secure the collar to the wire. Slide the main wheel in position, then use another wheel collar and setscrew to complete the wheel installation.

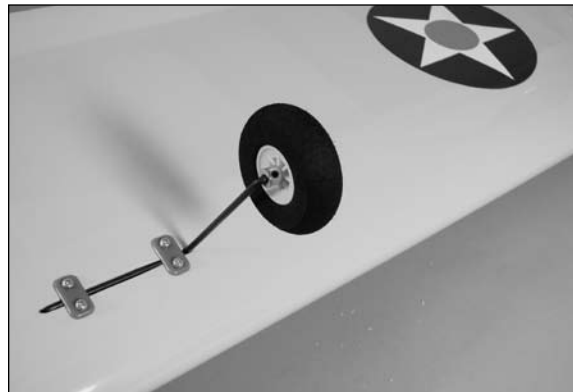
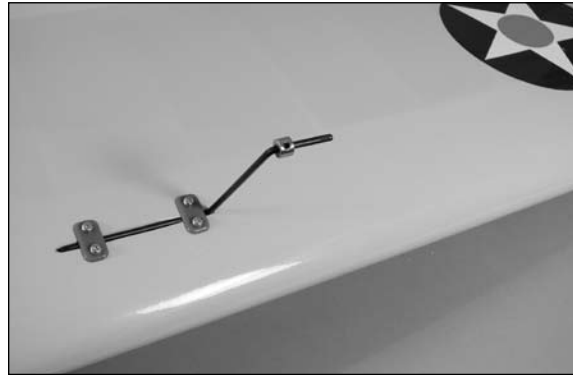

Important: Make sure to use threadlock on the setscrews to prevent them from vibrating loose.

□ Step 6

Repeat Steps 1 through 5 to install the remaining main landing gear and wheel. Note the positioning of the main gear in relationship to the aircraft.

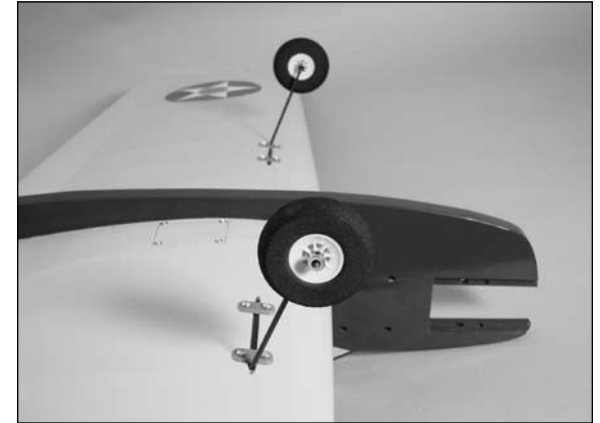

□ Step 7

Use a hobby knife and #11 blade to remove the covering at the rear of the fuselage for the tail wheel.



□ Step 8

Mix a small amount of 30-minute epoxy. Apply epoxy to the tail gear wire and the slot in the fuselage. Position the tail gear and use two #2 x 1/2-inch sheet metal screws to attach the tail gear to the fuselage. Allow the epoxy to fully cure before proceeding.

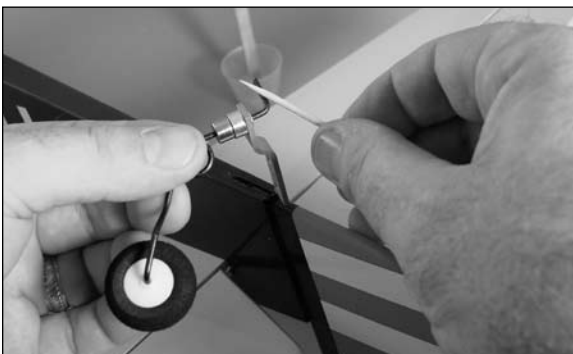

Hint: Before installing the screws, apply 2–3 drops of thin CA into each of the holes to harden the surrounding wood.

Engine Installation

Required Parts

- Assembled airframe
- Engine
- Spinner nut
- 4-40 lock nut (4)
- Aluminum engine mount plate (2)
- 4-40 x 1-inch socket head screw (4)
- Fuel tank
- Propeller
- #4 washer (4)

Required Tools and Adhesives

- Hex wrench: 3/32-inch
- Nut driver: 1/4-inch or adjustable wrench

□ Step 1

Inspect the fuel tank to determine the locations of the vent line inside the tank. Make sure the vent line of the tank is pointed towards the top left side of the fuel tank. If you need to, loosen the fuel tank cap and rotate the cap assembly until the vent is aligned properly.

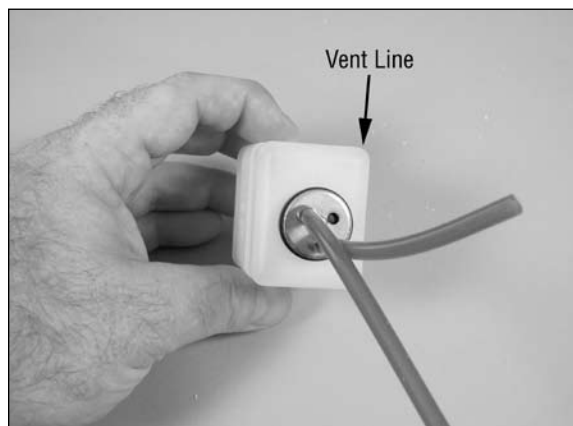

□ Step 2

Attach the fuel tank to the fuselage using the two tie wraps. Make sure the vent line is up and toward the fuselage when positioning the fuel tank.

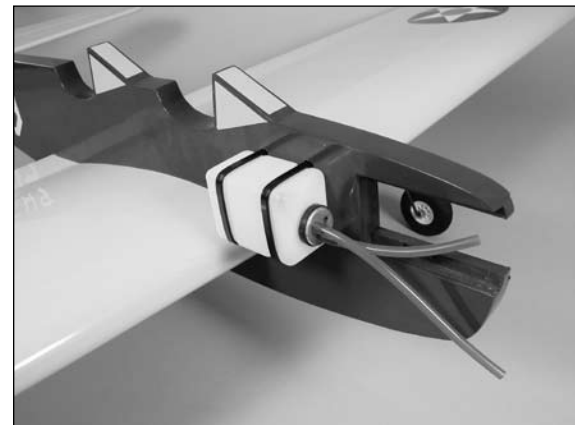

□ Step 3

Attach the engine to the fuselage using four 4-40 x 1-inch socket head screws, four #4 washers and four 4-40 lock nuts. Make sure to position the aluminum engine mounting plates between the nuts and left side of the fuselage or the nuts will dig into the wood engine mounts and become loose very quickly.

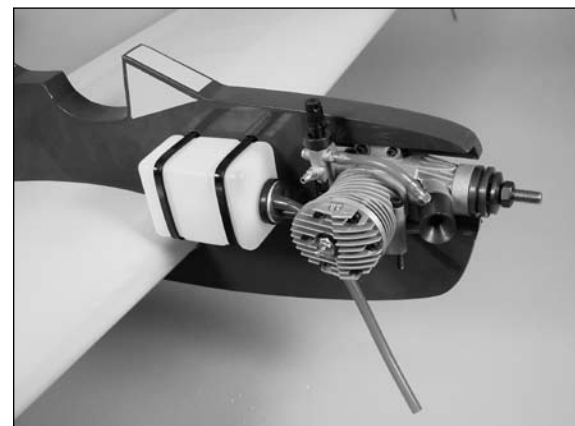

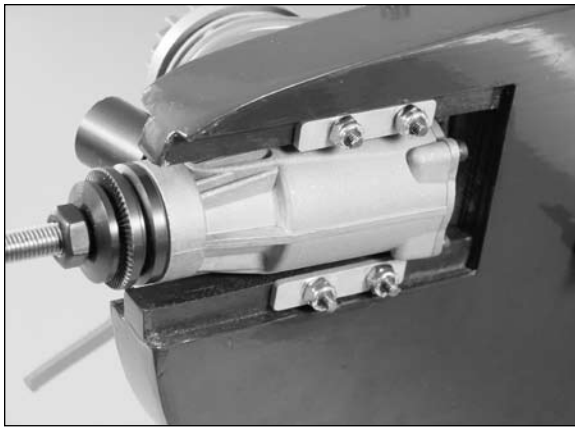

Hint: If you want more engine offset to increase the line tension, add an additional 4-40 washer between the engine mounting lugs and fuselage in the front two mounting holes. This will point the engine further to the right.

Step 4

Attach the muffler to the engine following the instructions provided with the engine. Either a standard muffler or special control line muffler can be used on your aircraft. Once installed, connect the lines from the fuel tank to the needle valve and muffler. Make sure the vent line from the tank connects to the muffler.

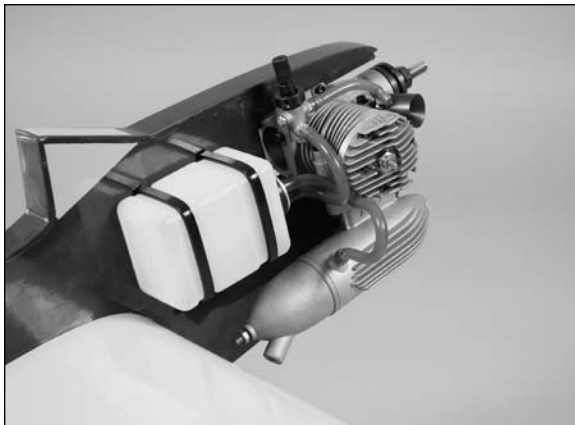

Note: The standard muffler supplied with the EVO 36CL engines provide the needed weight for proper balance.

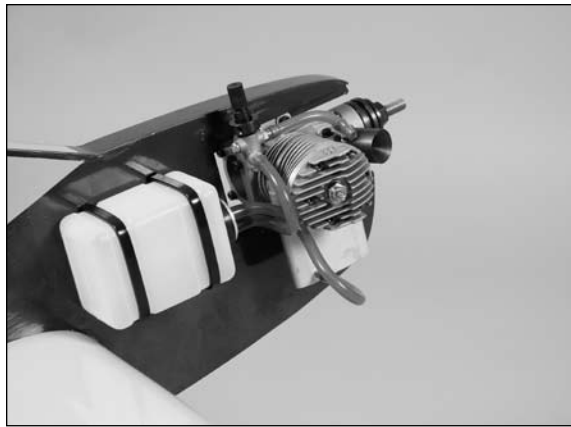

Step 5

Attach the propeller to the engine using the supplied spinner nut. Use a piece of bar stock or hex driver to tighten the nut and secure the propeller.



Hint: Install the propeller parallel to the wing when the engine is against compression. If the engine stops in flight, this will greatly reduce the chances of breaking the propeller on landing.

Handle Preparation

Required Parts

- Control handle
- Safety thong (black fabric strap)

Step 1

Attach the safety thong (black cloth strap) to the handle by tying it towards the bottom of the handle. Our preference is that the bolt through the handle is the top of the handle – but you can decide that for yourself.

Always use a safety thong when flying CL airplanes.



□ Step 2

Pass the strap through the loop so you can insert your hand through so that in the event you accidentally release the handle while flying your model, it will not free-flight away and do anyone any harm. You will only damage the model.

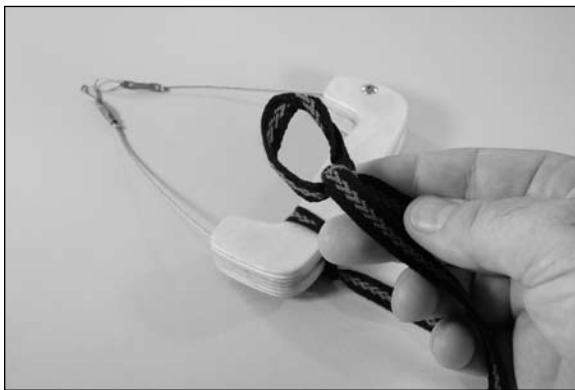

Connecting the Lines

Required Parts

- Assembled airframe
- Control handle
- Assembled control line
- Control line clip (4)

□□ Step 1

Attach the control line clip to the leadout wires from the handle.

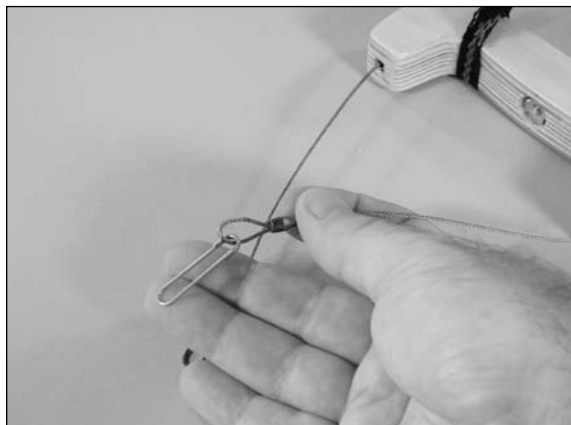

□□ Step 2

Attach the control line cables to the clips. This joins the handle to the control line cables.

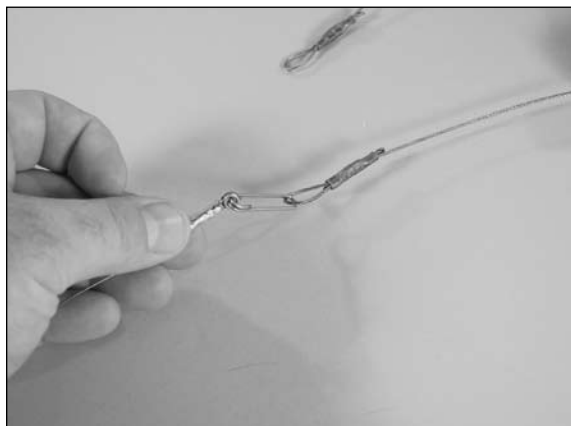

□ Step 3

Repeat Steps 1 and 2 to connect the control line cables to the leadout wires at the aircraft.

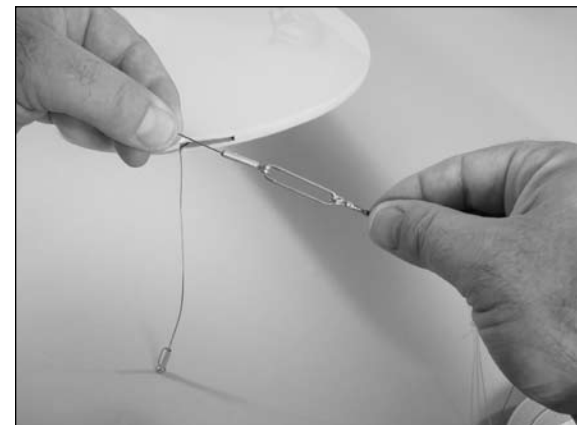

Hint: When disconnecting the control line cables, disconnect one connector from the leadout wire at the aircraft, and one from the control line cable. This will make it easy to connect the cables in their original orientation. Connecting them in reverse may result in slight trim changes to your aircraft.

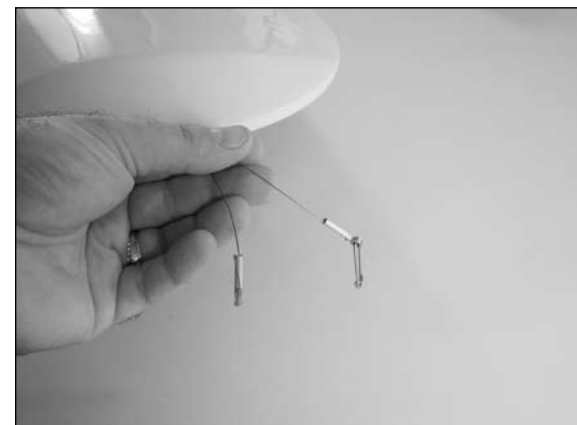

Hint: Use a 4-40 hex wrench to locate the locking screw on the moveable leadout guide inside the left wing tip. Make sure the leadout guide is slid to the forward (towards the front of the wing) position and tightened in place. This is the proper starting point for the adjustable leadout guide.

Center of Gravity

An important part of preparing the aircraft for flight is properly balancing the model.

Caution: Do not inadvertently skip this step!

The recommended Center of Gravity (CG) location for the PT-19 CL is 2 1/2-inch (63mm) back from the leading edge of the wing. Mark the location for the Center of Gravity on the top of the wing next to the fuselage as shown.

When balancing your PT-19 CL, support the plane inverted at the marks made on the top of the wing with your fingers or a commercially available balancing stand. This is the correct balance point for your model. You might find you may be required to add a small amount of weight to either the front or back of the fuselage to achieve the correct balance.

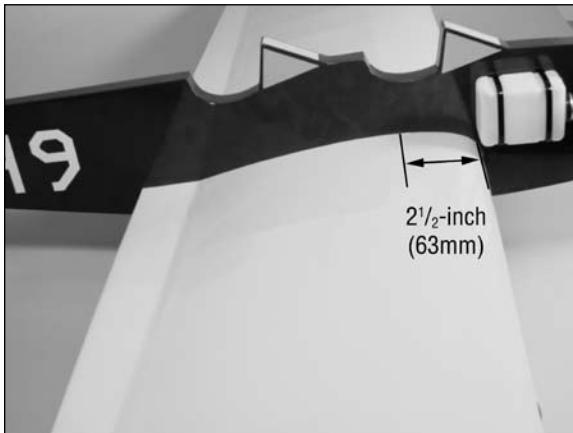

After the first flights, the CG position can be adjusted for your personal preference.

Daily Flight Checks

FLYING SITE

Your flying area should be about 150' diameter clear circle, with a smooth takeoff and landing surface. **DO NOT FLY NEAR POWERLINES!!!** Contact between the power lines and your flying lines can result in death. Be sure your flying area is clear and that transient walkers will not inadvertently walk through your flight path. It is highly recommended to mark your flying circle to warn others of the path of your aircraft to prevent injury to spectators.

HARDWARE CHECKS

Check all hardware (linkages, screws, nuts, and bolts) prior to each day's flight. Be sure that binding does not occur and that all parts are properly secured.

PREPARING FOR FLIGHT

Control Lines. Your PT-19 comes to you with a set of .015 x 60' 7-strand braided stainless steel cables for flying use. Attach these to the airplane with the supplied clips, and unroll the lines from the reel. Attach the other end of the lines to your handle, making sure that you have attached the 'up' line to the 'up' side of the handle, and vice versa for the down line.

When flying, always inspect your control line for damage, and discard any sets that have broken cables, or permanent kinks and bends in them. These areas are very weak and the possibility exists that the line will break in flight, causing the loss of your model. Keep your lines clean with alcohol and stored on the reel supplied, and you should get many flights from a set of lines.

FUEL

The fuel recommended is 5–15% nitro fuel, with 18% oil. The fuel tank we supplied is only about 2 1/2 ounces ... perfect for those of you who are just getting back into the hobby and don't (can't) spin in a circle for 5 minutes. A full fuel tank will give you about 3 1/2 minutes of flying time. The higher the nitro – the shorter the run time, the lower the nitro, the longer the run time. To increase flight times it is suggested to use a larger tank from Dubro or Sullivan. (DUB404 or SUL425).

PROPELLERS

For the first times around the circle, a good 10 x 6 or 10 x 5 prop, set at about 9500 rpm on the ground, will give you a comfortable flight speed. The EVOE100P trainer propeller (three blade 10.5 x 4.5) does a really nice job of flying this airplane and you should have a lot of fun with this combination. Propeller choice is always up to the pilot.

FIRST FLIGHTS

Remember, it does not take large movements to fly a control line airplane. For the first couple of flights concentrate on keeping your wrist and forearm locked into a position, and move your hand up and down at the elbow. This will provide the needed amount of control movement while stabilizing the airplane and leading to a very successful flight. If you start by moving your wrist up and down, the airplane will respond very rapidly and it could result in damage. Take your time and relearn the skills you used to have ... and you'll have a blast again!

Safety Do's and Don'ts for Pilots

- Check all control surfaces prior to each takeoff.
- Do not fly your model near spectators, parking areas or any other area that could result in injury to people or damage of property.
- Do not fly during adverse weather conditions. Poor visibility can cause disorientation and loss of control of your aircraft. Strong winds can cause similar problems.
- Do not take chances. If at any time during flight you observe any erratic or abnormal operation, land immediately and do not resume flight until the cause of the problem has been ascertained and corrected. Safety can never be taken lightly.
- Do not fly near power lines.

Safety, Precautions and Warnings

As the user of this product, you are solely responsible for operating it in a manner that does not endanger yourself and others or result in damage to the product or the property of others.

Carefully follow the directions and warnings for this and any optional support equipment (chargers, rechargeable battery packs, etc.) that you use.

- Make sure your flying area is clear of all utility wires or poles. Never fly a model aircraft closer than 50 feet to any above-ground electric utility lines.
- Always operate your model in an open area away from cars, traffic or people.
- Avoid operating your model in the street where injury or damage can occur.
- Never operate the model out into the street or populated areas for any reason.
- Carefully follow the directions and warnings for this and any optional support equipment (chargers, rechargeable battery packs, etc.) that you use.
- Keep all chemicals, small parts and anything electrical out of the reach of children.

Warranty Information

Warranty Period

Horizon Hobby, Inc., (Horizon) warrants that the Products purchased (the "Product") will be free from defects in materials and workmanship at the date of purchase by the Purchaser.

Limited Warranty

(a) This warranty is limited to the original Purchaser ("Purchaser") and is not transferable. REPAIR OR REPLACEMENT AS PROVIDED UNDER THIS WARRANTY IS THE EXCLUSIVE REMEDY OF THE PURCHASER. This warranty covers only those Products purchased from an authorized Horizon dealer. Third party transactions are not covered by this warranty. Proof of purchase is required for warranty claims. Further, Horizon reserves the right to change or modify this warranty without notice and disclaims all other warranties, express or implied.

(b) Limitations- HORIZON MAKES NO WARRANTY OR REPRESENTATION, EXPRESS OR IMPLIED, ABOUT NON-INFRINGEMENT, MERCHANTABILITY OR FITNESS FOR A PARTICULAR PURPOSE OF THE PRODUCT. THE PURCHASER ACKNOWLEDGES THAT THEY ALONE HAVE DETERMINED THAT THE PRODUCT WILL SUITABLY MEET THE REQUIREMENTS OF THE PURCHASER'S INTENDED USE.

(c) Purchaser Remedy- Horizon's sole obligation hereunder shall be that Horizon will, at its option, (i) repair or (ii) replace, any Product determined by Horizon to be defective. In the event of a defect, these are the Purchaser's exclusive remedies. Horizon reserves the right to inspect any and all equipment involved in a warranty claim. Repair or replacement decisions are at the sole discretion of Horizon. This warranty does not cover cosmetic damage or damage due to acts of God, accident, misuse, abuse, negligence, commercial use, or modification of or to any part of the Product. This warranty does not cover damage due to improper installation, operation, maintenance, or attempted repair by anyone other than Horizon. Return of any goods by Purchaser must be approved in writing by Horizon before shipment.

Damage Limits

HORIZON SHALL NOT BE LIABLE FOR SPECIAL, INDIRECT OR CONSEQUENTIAL DAMAGES, LOSS OF PROFITS OR PRODUCTION OR COMMERCIAL LOSS IN ANY WAY CONNECTED WITH THE PRODUCT, WHETHER SUCH CLAIM IS BASED IN CONTRACT, WARRANTY, NEGLIGENCE, OR STRICT LIABILITY. Further, in no event shall the liability of Horizon exceed the individual price of the Product on which liability is asserted. As Horizon has no control over use, setup, final assembly, modification or misuse, no liability shall be assumed nor accepted for any resulting damage or injury. By the act of use, setup or assembly, the user accepts all resulting liability.

If you as the Purchaser or user are not prepared to accept the liability associated with the use of this Product, you are advised to return this Product immediately in new and unused condition to the place of purchase.

Law: These Terms are governed by Illinois law (without regard to conflict of law principals).

Safety Precautions

This is a sophisticated hobby Product and not a toy. It must be operated with caution and common sense and requires some basic mechanical ability. Failure to operate this Product in a safe and responsible manner could result in injury or damage to the Product or other property. This Product is not intended for use by children without direct adult supervision. The Product manual contains instructions for safety, operation and maintenance. It is essential to read and follow all the instructions and warnings in the manual, prior to assembly, setup or use, in order to operate correctly and avoid damage or injury.

Questions, Assistance, and Repairs

Your local hobby store and/or place of purchase cannot provide warranty support or repair. Once assembly, setup or use of the Product has been started, you must contact Horizon directly. This will enable Horizon to better answer your questions and service you in the event that you may need any assistance. For questions or assistance, please direct your email to productsupport@horizonhobby.com, or call 877.504.0233 toll free to speak to a service technician.

Inspection or Repairs

If this Product needs to be inspected or repaired, please call for a Return Merchandise Authorization (RMA). Pack the Product securely using a shipping carton. Please note that original boxes may be included, but are not designed to withstand the rigors of shipping without additional protection. Ship via a carrier that provides tracking and insurance for lost or damaged parcels, as **Horizon is not responsible for merchandise until it arrives and is accepted at our facility**. A Service Repair Request is available at www.horizonhobby.com on the "Support" tab. If you do not have internet access, please include a letter with your complete name, street address, email address and phone number where you can be reached during business days, your RMA number, a list of the included items, method of payment for any non-warranty expenses and a brief summary of the problem. Your original sales receipt must also be included for warranty consideration. Be sure your name, address, and RMA number are clearly written on the outside of the shipping carton.

Warranty Inspection and Repairs

To receive warranty service, you must include your original sales receipt verifying the proof-of-purchase date. Provided warranty conditions have been met, your Product will be repaired or replaced free of charge. Repair or replacement decisions are at the sole discretion of Horizon Hobby.

Non-Warranty Repairs

Should your repair not be covered by warranty the repair will be completed and payment will be required without notification or estimate of the expense unless the expense exceeds 50% of the retail purchase cost. By submitting the item for repair you are agreeing to payment of the repair without notification. Repair estimates are available upon request. You must include this request with your repair. Non-warranty repair estimates will be billed a minimum of ½ hour of labor. In addition you will be billed for return freight. Please advise us of your preferred method of payment. Horizon accepts money orders and cashiers checks, as well as Visa, MasterCard, American Express, and Discover cards.

If you choose to pay by credit card, please include your credit card number and expiration date. Any repair left unpaid or unclaimed after 90 days will be considered abandoned and will be disposed of accordingly. **Please note: non-warranty repair is only available on electronics and model engines.**

United States:

Electronics and engines requiring inspection or repair should be shipped to the following address:

Horizon Service Center
4105 Fieldstone Road
Champaign, Illinois 61822

All other Products requiring warranty inspection or repair should be shipped to the following address:

Horizon Product Support
4105 Fieldstone Road
Champaign, Illinois 61822

Please call 877-504-0233 or e-mail us at productsupport@horizonhobby.com with any questions or concerns regarding this product or warranty.

United Kingdom:

Electronics and engines requiring inspection or repair should be shipped to the following address:

Horizon Hobby UK
Units 1-4 Ployters Rd
Staple Tye
Harlow, Essex
CM18 7NS
United Kingdom

Please call +44 (0) 1279 641 097 or e-mail us at sales@horizonhobby.co.uk with any questions or concerns regarding this product or warranty.

Germany:

Electronics and engines requiring inspection or repair should be shipped to the following address:

Horizon Technischer Service
Hamburger Strasse 10
25335 Elmshorn
Germany

Please call +49 4121 46199 66 or e-mail us at service@horizonhobby.de with any questions or concerns regarding this product or warranty.

2008 Official Academy of Model Aeronautics Safety Code

GENERAL

1. A model aircraft shall be defined as a non-human-carrying device capable of sustained flight in the atmosphere. It shall not exceed limitations established in this code and is intended to be used exclusively for recreational or competition activity.
2. The maximum takeoff weight of a model aircraft, including fuel, is 55 pounds, except for those flown under the AMA Experimental Aircraft Rules.
3. I will abide by this Safety Code and all rules established for the flying site I use. I will not willfully fly my model aircraft in a reckless and/or dangerous manner.
4. I will not fly my model aircraft in sanctioned events, air shows, or model demonstrations until it has been proven airworthy.
5. I will not fly my model aircraft higher than approximately 400 feet above ground level, when within three (3) miles of an airport without notifying the airport operator. I will yield the right-of-way and avoid flying in the proximity of full-scale aircraft, utilizing a spotter when appropriate.
6. I will not fly my model aircraft unless it is identified with my name and address, or AMA number, inside or affixed to the outside of the model aircraft. This does not apply to model aircraft flown indoors.
7. I will not operate model aircraft with metal-blade propellers or with gaseous boosts (other than air), nor will I operate model aircraft with fuels containing tetranitromethane or hydrazine.
8. I will not operate model aircraft carrying pyrotechnic devices which explode burn, or propel a projectile of any kind. Exceptions include Free Flight fuses or devices that burn producing smoke and are securely attached to the model aircraft during flight. Rocket motors up to a G-series size may be used, provided they remain firmly attached to the model aircraft during flight. Model rockets may be flown in accordance with the National Model Rocketry Safety Code; however, they may not be launched from model aircraft. Officially designated AMA Air Show Teams (AST) are authorized to use devices and practices as defined within the Air Show Advisory Committee Document.
9. I will not operate my model aircraft while under the influence of alcohol or within eight (8) hours of having consumed alcohol.
10. I will not operate my model aircraft while using any drug which could adversely affect my ability to safely control my model aircraft.
11. Children under six (6) years old are only allowed on a flightline or in a flight area as a pilot or while under flight instruction.
12. When and where required by rule, helmets must be properly worn and fastened. They must be OSHA, DOT, ANSI, SNELL or NOCSAE approved or comply with comparable standards.

CONTROL LINE

1. I will subject my complete control system (including the safety thong where applicable) to an inspection and pull test prior to flying. The pull test will be in accordance with the current Competition Regulations for the applicable model aircraft category. Model aircraft not fitting a specific category shall use those pull-test requirements as indicated for Control Line Precision Aerobatics.
2. I will ensure that my flying area is clear of all utility wires or poles and I will not fly a model aircraft closer than 50 feet to any above-ground electric utility lines.
3. I will ensure that my flying area is clear of all nonessential participants and spectators before permitting my engine to be started.



Fly First Class™



© 2008 Horizon Hobby, Inc.
4105 Fieldstone Road
Champaign, Illinois 61822
(877) 504-0233
horizonhobby.com
Hangar9.com