

ULTRA STICK.60

INSTRUCTION MANUAL

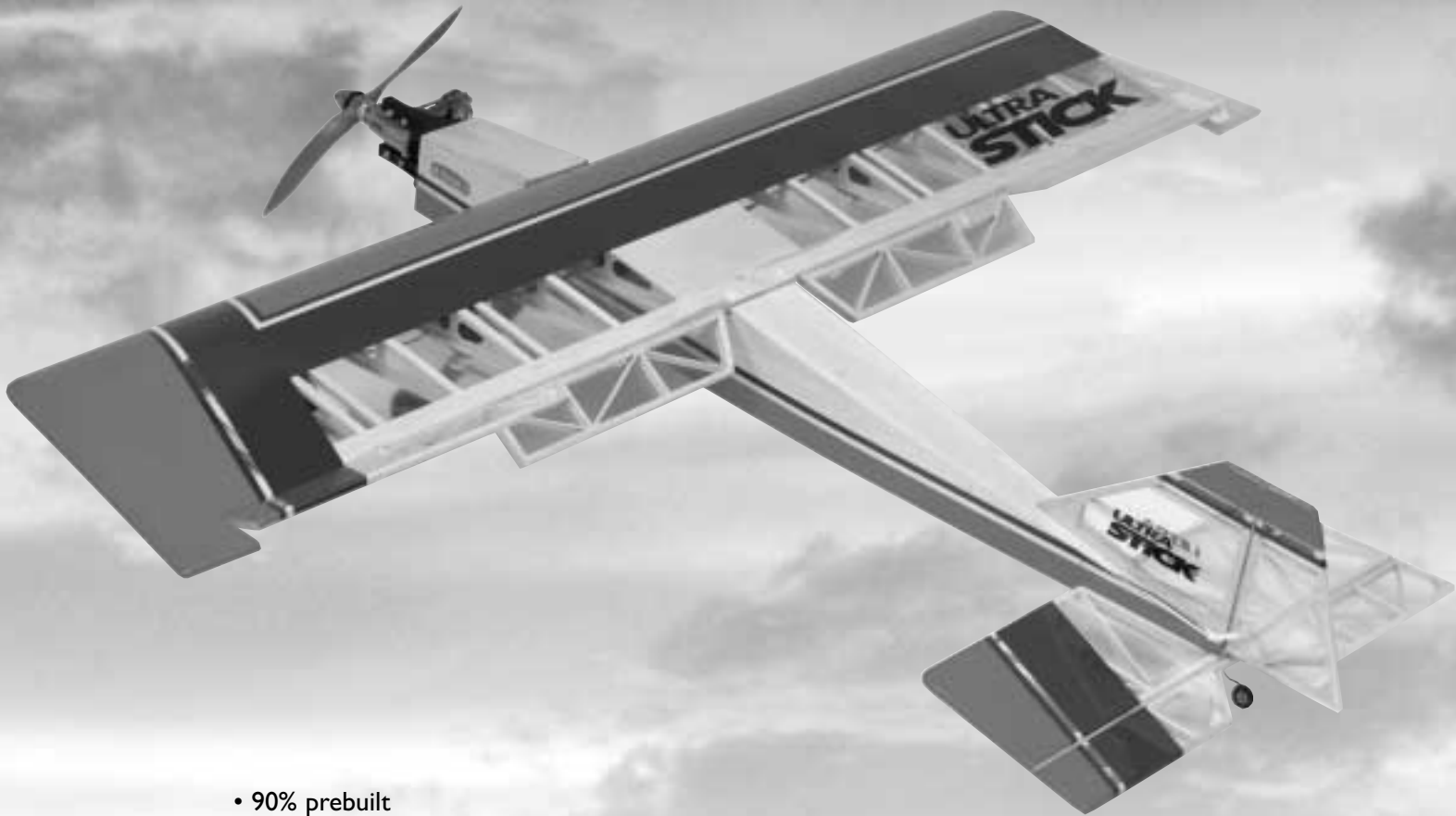

- 90% prebuilt
- Hardware included
- Precovered in genuine UltraCote®
- Everything included to build a conventional two aileron wing version or quad flap version



Specifications

Wingspan:	66 in (1676 mm)
Length:	55 in (1397 mm)
Wing Area:	2 AIL: 913 sq in (5934.5 sq dm), 4 AIL: 927 sq in (6025.5 sq dm)
Weight approximate:	6–7 lb (2.7–3.15 kg)
Recommended Engines:	2-cycle: .61–.78ci 4-cycle: .72–1.00ci

Table of Contents

- Introduction 3
- Warning 3
- Additional Required Equipment 4
- Part Needed 5
- Tools and Supplies Needed 5
- Kit Contents 6
- Section 1: Assembling the Conventional Wing 7
- Section 1a: Assembling the Quad Flap Wing 9
- Section 2: Joining the Wing Halves 11
- Section 3: Installing the Aileron/Flap Servos 14
- Section 4: Bolting the Wing to the Fuselage 17
- Section 5: Installing the Horizontal Stabilizer 20
- Section 6: Installing the Vertical Stabilizer (Fin) 22
- Section 7: Installing the Rudder and Tail Wheel Assembly 24
- Section 8: Hinging the Horizontal Stabilizer and Elevator 27
- Section 9: Installing the Rudder and Elevator Control Horns 28
- Section 10: Installing the Main Landing Gear 30
- Section 11: Assembling the Fuel Tank 31
- Section 12: Mounting the Engine 33
- Section 13: Installing the Radio System 35
- Section 14: Installing the Aileron and/or Quad Flap Linkages 37
- Section 15: Installing the Rudder, Elevator and Throttle Pushrod 40
- Section 16: Control Throw Recommendations 43
- Section 17: Balancing the Ultra Stick 40 43
- Section 18: Quad Flaps 44
- Section 19: Programming Guide 46
 - JRXP652/642 46
 - JRXP783/XP347/XP388S 52
 - JRXP8103 60
 - JRXP10X/10SXII/10SX 68
 - Futaba 8UA/S 72
- Range Test Your Radio 78
- AMA Safety Code 79

Introduction

Important

Before beginning construction of your Ultra Stick™ 60, you'll need to decide which wing configuration is best for you: the conventional two-aileron version or the quad flap version with two ailerons and two flaps.

With the conventional two-aileron wing, the Ultra Stick 60 is an outstanding sport aircraft. This configuration offers excellent slow speed and stall characteristics that even inexperienced pilots will feel right at home with in no time. Plus, it offers aerobatic capabilities that will have your flying buddies drooling. If you're using a 4- or 5-channel non-computer radio, the conventional two-aileron version is your best choice.

To get the most out of your Ultra Stick 60, we strongly suggest using a 6- to 10-channel computer radio and building the quad flap wing configuration. If you're relatively new to flying or aren't totally confident about your abilities, don't let the quad flaps scare you off. Quad flaps can actually make your Ultra Stick 60 easier to fly! Quad flaps allow your Ultra Stick 60 to perform in many amazing ways that just aren't possible with an ailerons-only equipped airplane. With a little practice, you'll be able to use crow mixing to do amazingly short landings from high altitudes. You'll do takeoffs within the length of the fuselage with takeoff flaps, high-speed rolls with aileron-to-flap mixing, and super-tight loops with elevator-to-flap mixing. Plus, you'll have fun learning about your computer radio and its capabilities.

Don't miss out on all the possible fun. Build your Ultra Stick 60 in the quad/flap configuration. If you're a bit intimidated about all of that programming complication, we've provided an easy-to-follow programming guide in the back of this manual that will walk you through every step of the way. Whether you own a JR 6-, 7-, 8-, or 10-channel computer radio or a Futaba 8, step-by-step instructions are provided, making programming easy!

If you encounter difficulty in any construction sequence, please feel free to contact one of our technicians—we stand ready to provide any assistance we can concerning the construction of your Ultra Stick 60. You can contact us at:

Horizon Hobby, Inc.
4105 Fieldstone Road
Champaign, IL 61822
(217) 355-9511
www.horizonhobby.com

Warning

An R/C aircraft is not a toy! If misused, it can cause serious bodily harm and damage to property. Fly only in open areas, preferably AMA (Academy of Model Aeronautics) approved flying sites, following all instructions included with your radio and engine.

Additional Required Equipment

Radio Equipment

4 channels (minimum)

5 servos (JR 537 or equivalent) or 7 servos for quad flap wing option

Standard 600–1100mAh receiver battery pack

Note: A Y-harness and a reversed servo is required if a 5- or 6-channel radio is used for quad flaps. A servo Y-harness with reverse, like Expert's 320 (EXRA320), can be used.

Recommended JR Systems

JR F421EX

JR XP631

JR XP652

JR XP8103

PCM10SX

PCM10SXII

PCM10X



JR 8103

Engine Requirements

.61–.78 2-cycle engines

.72–1.00 4-cycle engines

Recommended 2-Cycle Engines

MDS™ .68FS Pro/MDS .78FS Pro

Recommended 4-Cycle Engine

Saito™ .72–1.00



MDS .68FS Pro



Saito 100

Parts Needed (not included in kit)

Aileron extension - 12" (2) (JRPA100)

(Note: 4 aileron extensions will be required for the quad flap wing option)

Propeller (Refer to propeller recommendations in the operating instructions for your engine)

Foam for cushioning radio equipment

Fuel tubing (12")

Tools and Supplies Needed (not included in kit)

Adhesives

Thin CA (cyanoacrylate) glue

Medium CA (cyanoacrylate) glue

Thick CA (cyanoacrylate) glue

CA remover/debonder

6-minute epoxy

30-minute epoxy

Z-42 Threadlock

Tools

Drill

Drill Bit: 1/8", 1/16", 3/16", 3/32"

Phillips screwdriver (medium)

Z-bend pliers

Needle-nose pliers

Hobby knife with #11 blade

Mixing sticks

Epoxy brush

90-degree triangle

Sandpaper (medium)

Masking tape

Straight edge

Measuring device (e.g., ruler, tape measure)

Scissors

Paper towels

Wax paper

Rubbing alcohol

Felt-tipped pen/pencil

T-pins

Toothpicks (optional)

Moto-tool with cut-off wheel

Other

Radio packing foam

Antenna tube

Kit Contents

Large Parts

1. Fuselage (HAN2352)
2. Wing Set w/Standard Aileron (HAN2351)
3. Tail Set (HAN2353)
4. Optional Flap/Aileron Parts (for quad flap wing) (HAN2354)
5. Landing Gear (HAN2355)

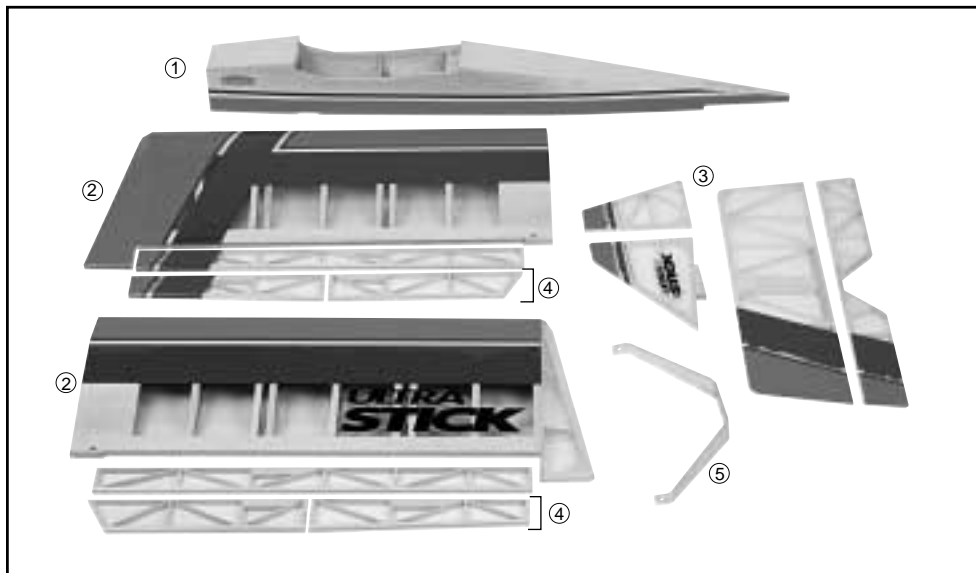

Small Parts

- A. Pushrods
- B. Wheels 2³/₄" (HAN305)
- C. Engine Mount w/Hardware (HAN90M)
- D. Fuel Tank 10.8 oz
- E. Tail Wheel Assembly
- F. Main Wheel Axles
- G. Tail Wheel 1³/₄"
- H. Wing Mounting Hardware
- I. Nylon Control Horns (6)
- J. Nylon 2-56 Clevis (6)
- K. Wire Keepers

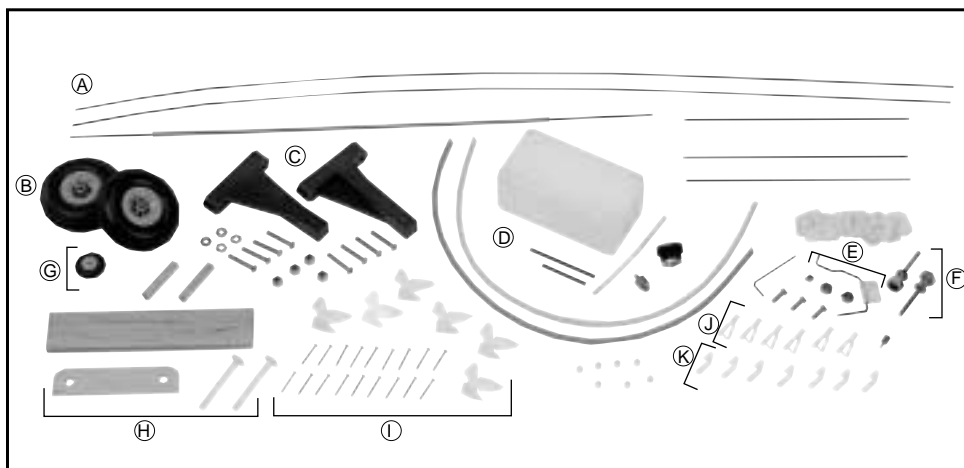

Section 1:

Assembling the Conventional Wing

Items Needed

Parts Needed

Right wing panel with aileron and hinges
Left wing panel with aileron and hinges

Tools and Adhesives Needed

Instant thin CA glue
CA remover/debonder
Paper towels
T-pins (one for each hinge)
Hobby knife with #11 blade

Before beginning construction, decide what style of wing is desired (conventional or quad flap) and what type of engine will be mounted on the model. The conventional aileron wing will be presented in this section. Each aileron will be controlled by its own servo. You will need two servos when you begin Section 3.

For a standard wing configuration, we recommend a servo that has 40 oz/in of torque or greater, such as the JR 537 servo that now comes standard with JR radio systems. The JR 531 or 8101 servos are also excellent to use for aileron servos in the wing.

Note: The control surfaces, including the ailerons, flaps, elevator, and rudder, come with the hinges installed, but the hinges are not glued in place. It's imperative that you use a high quality thin CA glue to properly adhere the hinges and control surfaces in place.

Step 1. Carefully remove one of the wing panels from its protective plastic. Save the plastic, as it will be used later in Section 2 to protect the wing panel surface from epoxy smears. Remove the aileron from the wing panel. Note the position of the hinges.

Step 2. Remove each hinge from the wing panel and place a T-pin in the center outside edge of each hinge. Slide each hinge into the wing panel until the T-pin is snug against the wing.



Step 3. Slide the aileron onto the wing until there's only a slight gap (approx. 1/32" or less). The hinges are now centered on the wing panel and aileron. Remove the T-pin and snug the aileron against the wing panel. This will ensure that the hinges are centered.



Note: The hinge is constructed of a special material that allows the CA to wick (or penetrate) and distribute throughout the hinge, securely bonding it to the wood structure. Before applying CA, make sure the aileron moves freely without binding on the wing.

Step 4. Deflect the aileron and completely saturate the hinge with thin CA glue. The aileron's front surface should lightly contact the wing during this procedure. Ideally, when the hinge is glued in place, a 1/32" gap or less will be maintained throughout the length of the aileron.



Section 1:

Assembling the Conventional Wing

CONTINUED

Step 5. Turn the wing panel over and deflect the aileron in the opposite direction from the previous step. Again apply thin CA glue to each aileron hinge, making sure the CA penetrates into both the aileron and the wing.



Step 6. Using CA remover/debonder and a paper towel, remove any excess CA glue that may have accumulated on the wing or in the aileron hinge area.



Step 7. Repeat Steps 1 through 6 for the opposite wing half before moving onto Step 8.

Step 8. After both ailerons are securely hinged, firmly grasp the wing and aileron to check that the hinges are securely glued and cannot be pulled apart. To do this, apply medium pressure to try to separate the aileron from the wing, using caution to be certain you don't crush the wing structure.



Step 9. Move the aileron up and down to "work in" the hinges and check for proper movement.

Section 1a:

Assembling the Quad Flap Wing

Items Needed

Parts Needed

Right wing panel with aileron and hinges
Left wing panel with aileron and hinges
Right wing aileron/flap
Left wing aileron/flap

Tools and Adhesives Needed

Instant thin CA glue
CA remover/debonder
Paper towels
T-pins (one for each hinge)
Sealing iron
Hobby knife with #11 blade

Note: The procedure for hinging the flap/aileron in each wing panel is the same as described for the conventional wing.

Step 1a. Locate the plastic bag containing the flap/aileron pieces for each wing panel and remove from the package. Carefully remove one of the wing panels from the protective plastic bag. Save the plastic bag for use in Section 2. Remove the conventional aileron from the wing panel.

Step 2a. Remove the hinges from the wing panel and place a T-pin in the center outside edge of each hinge. Slide each hinge into the wing panel until the T-pin is snug against the wing.



Step 3a. Slide the aileron and flap control surface onto the wing panel until there's only a slight gap (approximately 1/32"). The hinges are now centered on the wing panel and the control surfaces. Remove the T-pins and snug each control surface to the wing panel. This will ensure the hinges are centered.



Note: The hinge is constructed of a special material that allows the CA to wick (or penetrate) and distribute throughout the hinge, securely bonding it to the wood structure. Before applying CA, make sure the flap and aileron move freely without binding on the wing or with each other.

Section 1a:

Assembling the Quad Flap Wing

CONTINUED

Step 4a. Deflect the aileron and flap and completely saturate each hinge with thin CA glue. The aileron and flap's front surface should lightly contact the wing during this procedure. Ideally, when the hinges are glued in place, a 1/32" gap or less will be maintained throughout the length of the aileron and flap.



Step 5a. Turn the wing panel over and deflect the aileron and flap in the opposite direction from the previous step. Apply thin CA glue to each aileron hinge, making sure the CA penetrates into the aileron, flap, and the wing.



Step 6a. Using CA remover/debonder and a paper towel, remove any excess CA glue that may have accumulated on the wing aileron or flap hinge area.



Step 7a. Repeat Steps 1A through 6A for the opposite wing panel.

Step 8a. After both the aileron and flap control surfaces are securely hinged, firmly grasp the wing, flap, and aileron to check that they are securely glued and cannot be pulled apart. To do this, apply medium pressure to try to separate the control surfaces from the wing. Use caution to be certain you don't crush the wing structure.



Step 9a. Move the control surfaces up and down to "work in" the hinges and check for proper movement.

Important: If any binding has developed between the control surfaces, it must be removed. You may have to trim away some covering or balsa to make each control surface move freely.

Section 2:

Joining the Wing Halves

Items Needed

Parts Needed

Right/left wing panels
Plastic wing bags (optional)
Wing joiner brace

Tools and Adhesives Needed

30-minute epoxy	Rubbing alcohol
Epoxy brush	Paper towels
Mixing stick	Wax paper
T-pin	Ruler
Masking tape	Pencil
Hobby knife	

Step 1. Locate the wing joiner. Using a ruler, determine the center of the brace and mark it with a pencil.



Step 2. Trial fit the wing joiner into one of the wing panels. It should insert smoothly up to the centerline marked in Step 1. Now slide the other wing panel onto the wing joiner until the wing panels meet. If the fit is overly tight, it may be necessary to sand the wing joiner.



Step 3. The Ultra Stick™ 60 is designed with "0" dihedral. Place the wing on a large flat surface. The spar, (highpoint of the wing), should be flat on the surface.

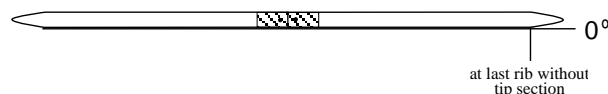

Step 4. Separate the wing halves and remove the wing joiner. Once you're satisfied with the trial fit of the wing panels, you can prepare to epoxy the wing panels together.

Note: Use the plastic wing bags as a means of keeping epoxy from smearing on the wings. Just slip one on each panel and use masking tape to hold them in place.

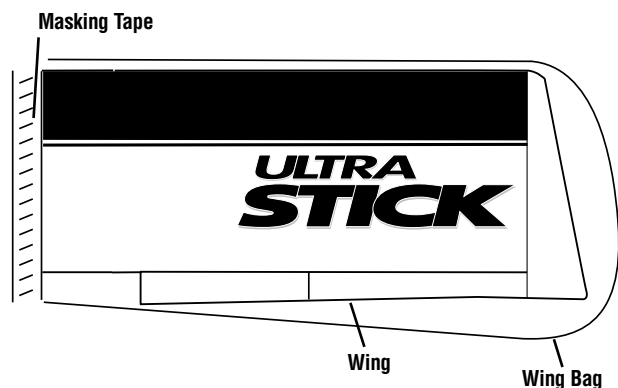

Important: Read through each of the remaining steps of this section before proceeding to epoxy the wing halves together

Step 5. Mix approximately 1 ounce of 30-minute epoxy.

Note: It's extremely important to use plenty of epoxy when gluing the wing halves together.

Section 2:

Joining the Wing Halves

CONTINUED

Step 6. Place one wing half right side up on a flat work surface.

Note: It's helpful to put wax paper under the wing.

Using an epoxy brush, smear a generous amount of epoxy into the wing joiner cavity in the wing panel.



Step 7. Coat one half of the wing joiner with epoxy up to the pencil line drawn in Step 1. Install the epoxy-coated half of the wing joiner into the wing joiner cavity up to the marked center-line. Any excess epoxy can be cleaned up with rubbing alcohol and paper towels.



Note: You will need to mix an additional 1-2 ounces of epoxy to complete the wing joining process

Step 8. Apply a generous amount of epoxy into the wing joiner cavity of the other wing panel.



Step 9. Install a T-pin into the wing joiner at the center mark. This will allow you to keep the brace "in the center" of the wing when joining the two wing halves. Next, apply epoxy to all sides of the exposed area of the wing joiner and uniformly coat both wing roots with epoxy.



Section 2:

Joining the Wing Halves

CONTINUED

Step 10. Carefully slide the two wing halves together and firmly press them together, allowing the excess epoxy to run out. Check to make sure the wing panels align properly. Wipe any excess epoxy away with rubbing alcohol and paper towels. The plastic wing bag can be removed from the wing halves after the epoxy has been applied.

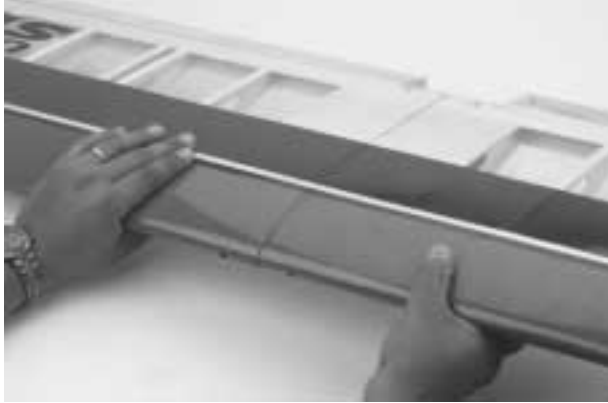

Note: It's helpful to use wax paper underneath the wing center while the epoxy is curing to prevent excess epoxy from adhering to the work surface area.

Step 11. Apply masking tape at the wing joint to hold the wing halves together securely. Place the wing right side up on a flat surface. With the wing lying flat on a surface without any dihedral, apply more masking tape to the wing center joint and recheck that the wing remains flat. Also make sure the wing halves are still properly aligned. Allow the wing joint epoxy to cure completely (overnight).

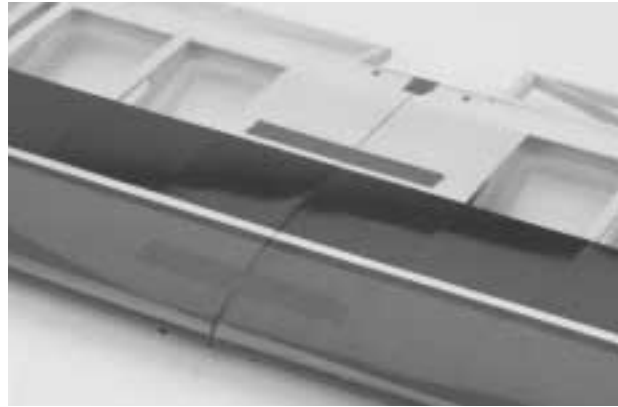

Step 12. Once the epoxy has cured completely, remove the masking tape.

Section 3:

Installing the Aileron/Flap Servos

Items Needed

Parts Needed

Assembled wing
Servo extension - 12" (2)
(2 additional 24" for quad-flap configuration wing)
Standard size servos with mounting hardware (2)
(4 for quad/flap configuration)

Note: The flap servo must be reversed if using a Y-harness for flaps.

Tools and Adhesives Needed

Hobby knife
Phillips screwdriver (medium)
Drill
Drill Bit: 1/16"
Masking tape
Pencil
String with weight on end
Needle-nose pliers

Step 1. Locate the servo openings in the bottom of each of the wing halves. Use a sharp hobby knife to trim away the covering over the openings. If you're building the conventional wing, you will only cut out the openings that are closest to the wing root for the aileron servos. If you build the quad flap wing, trim away the covering on all four servo openings in the wing. Use care not to cut away too much of the covering.



Step 2. Install the recommended servo hardware supplied with your radio system onto your servos, (grommets and eyelets). Install 12" servo extensions on the flap servo lead and 24" extensions on the aileron servo leads. Secure the connectors with either masking tape or a commercial connector that prevents the servo lead connections from becoming disconnected.

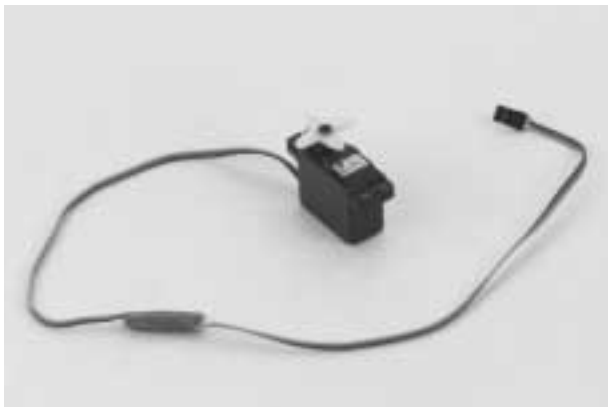

Hint: It's always a good idea to tape or secure the servo connectors and servo extension together to prevent the wires from becoming unplugged inside the wing.

Step 3. Trial fit the servo into the servo opening. Depending upon the type of servo installed, some trimming may be required. Note that the servo is orientated so the servo output shaft is closer to the trailing edge of the wing.



Step 4. With the servo in place, mark the location of the servo screws and then remove the servo.



Section 3:

Installing the Aileron/Flap Servos

CONTINUED

Step 5. Using a 1/16" drill bit, drill the servo screw locations marked in Step 4.



Step 6. Repeat the procedure for the other servo(s).

Step 7. Before mounting the servos in the wing, it's suggested that the servo extensions be run through the wing and out the opening near the root rib.

Step 8. Locate the two circular servo lead exits near the center of the wing bottom. Using a sharp hobby knife, trim away the covering to expose the openings, making sure to use caution so you don't cut into the wing sheeting.



Step 9. To thread the servo lead extensions/servo leads through the wing, we suggest using a 24" piece of string with a weight attached (such as one of the wheel collars in the kit). Thread it from the servo opening down through the wing structure and out the exit opening at the center of the wing.



Step 10. Once the string is threaded through the wing, you can fish it out with your fingers or let the weight drop out the opening. Tape each end to the wing to keep it from falling back into the opening. When you're ready to thread the servo extension and servo lead through the wing, simply tie the string to the extension and carefully thread them through the wing by pulling the string/lead through the openings.

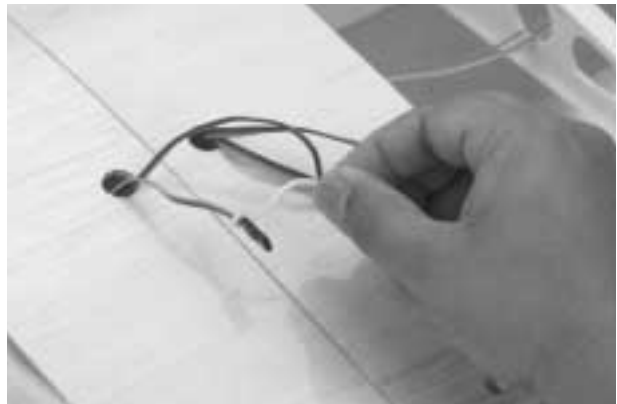

Section 3:

Installing the Aileron/Flap Servos

CONTINUED

Step 11. Tape the lead to the wing to keep it from falling back into the opening. It may be easier if you thread one servo lead at a time.



Step 12. Securely fasten the servo in the opening with four of the servo mounting screws supplied with your radio system. We suggest you mark which lead is an aileron lead and which is a flap lead. Apply masking tape to the appropriate lead and mark either "F" for flap or "A" for aileron.

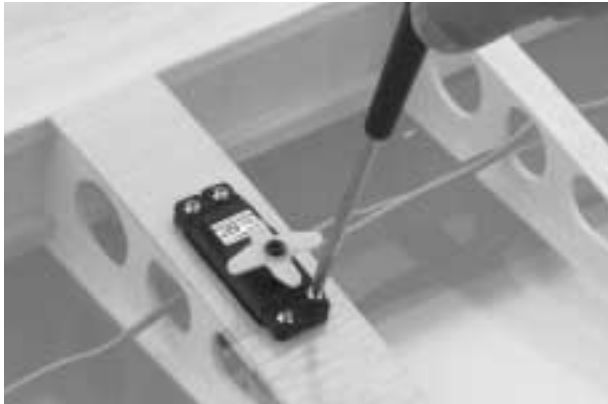

Step 13. Repeat the procedure for the other servo(s).

Note: It was intended to have each servo connected to a specific channel in the receiver, however you can use a Y-harness to connect two ailerons to one aileron channel or two flaps to one flap channel, which will require one of the flap servos to be a reversed servo. This will reduce your programming options. Please refer to Section 19 for computer radio programming for the Ultra Stick™ 60.

Installing the linkages and control horns to the ailerons/flaps will be addressed later in the manual.

Section 4:

Bolting the Wing to the Fuselage

Items Needed

Parts Needed

Fuselage	Wing-bolt plate
Wing	Wing bolts
Leading edge wing dowels	

Tools and Adhesives Needed

Hobby knife	Ruler (36" or tape measure)
File (round)	6-minute epoxy
Flat screwdriver	Rubbing alcohol
Felt-tipped pen/pencil	Paper towels

Note: Your Hangar 9™ Ultra Stick™ 60 comes from the factory with two predrilled holes in the leading edge of the wing for the alignment dowels, and two predrilled holes for the wing hold down bolts. The Ultra Stick 60 comes with the wing bolt T-nuts preinstalled in the fuselage.

Step 1. Locate the predrilled leading edge dowel holes located on both sides of the center joint of the wing.

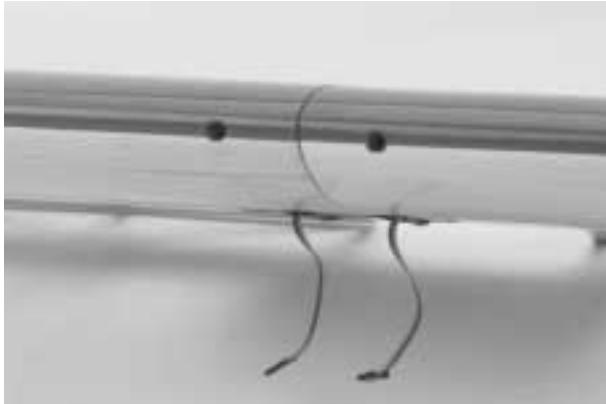

Step 2. Locate and trial fit the leading edge wing dowels into the holes in the leading edge. There should be approximately 1/2 of dowel protruding from the leading edge of the wing, (trim the dowels as necessary). Mark each dowel where it exits the leading edge of wing.



Step 3. Remove the wing dowels and mix about 1/2 ounce of 6-minute epoxy. Use a generous amount of epoxy in the leading edge holes and on the portion of the dowels that will be inserted into the wing. Insert dowels into the wing and wipe off any excess epoxy. Set wing aside and allow epoxy to cure.



Step 4. After the epoxy has cured for the leading edge alignment dowels, trial fit the wing to the fuselage by inserting the dowels into the former in front of the wing saddle of the fuselage. If the wing dowel fit is too tight, carefully enlarge the holes in the former just enough to get the wing dowels inserted.



Section 4:

Bolting the Wing to the Fuselage

CONTINUED

Step 5. Locate the wing-bolt hold-down plate. Note the wing-bolt hold-down plate has the holes already drilled out for the wing bolts. The holes in the wing bolt plate have the same spacing as the preinstalled blind nuts in the fuselage. Carefully remove the covering over the predrilled openings using a sharp hobby knife.



Step 6. Using a ruler and felt-tipped pen, measure and mark the center of the fuselage at the tail end just above the horizontal stabilizer mounting saddle. Insert a T-pin at the mark you made.



Step 7. Insert the wing bolts through the wing-bolt plate (covered side up) and insert the bolts through the wing-bolt holes in the wing. Install the wing onto the fuselage and snug the wing bolts down finger tight.



Step 8. Check the alignment of the wing by measuring the distance from the wing tip to the T-pin you installed in Step 6. Make sure to measure from the same spot on both wing tips. Once satisfied with alignment, tighten the wing bolts securely.

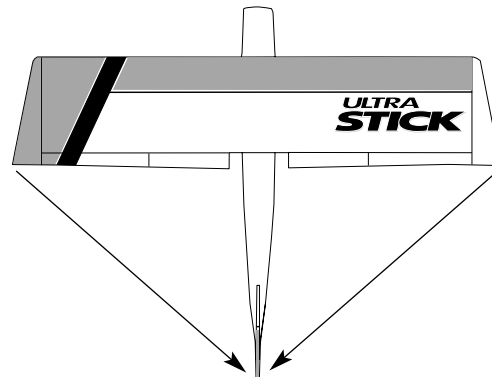

Section 4:

Bolting the Wing to the Fuselage

CONTINUED

Step 9. Using a felt-tipped pen or pencil, carefully mark around the outside of the wing bolt plate.



Step 10. Remove the wing from the fuselage and using a sharp hobby knife, carefully trim away the covering on the wing 1/8" inside the lines you marked for the wing-bolt plate. Be sure to avoid cutting into the balsa wood.

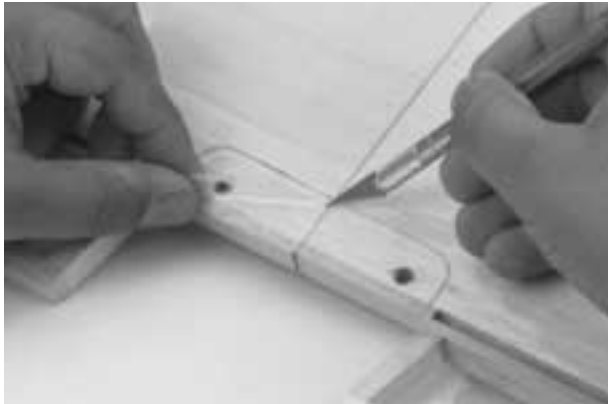

Step 11. Mix approximately 1/4 ounce of 6-minute epoxy and glue the wing hold-down plate onto the wing. Wipe off any excess epoxy and remove any epoxy from the wing-bolt holes. Allow the epoxy to completely cure before proceeding.



Section 5:

Installing the Horizontal Stabilizer

Items Needed

Parts Needed

Horizontal stabilizer
Fuselage
Assembled wing

Tools and Adhesives Needed

Hobby knife
Ruler
Felt-tipped pen
Pencil
30-minute epoxy

Paper towels
Rubbing alcohol
Mixing stick
Epoxy brush
Masking tape

Note: Before assembling the tail, be sure the elevator and the CA hinges are removed from the horizontal stabilizer. The hinges and elevator will be installed later.

Step 1. Measure and mark the center of the horizontal stabilizer on its trailing edge.



Step 2. On the bottom of the aft end of the fuselage is a saddle cut out for the horizontal stabilizer to be mounted. Make a center mark on the back of the saddle and place the horizontal stabilizer into the horizontal stabilizer saddle. Align the two marks you made. Tape the leading edge and trailing edge of the horizontal stabilizer to the fuselage to secure it for now.



Step 3. Install the wing onto the fuselage.

Step 4. With the fuselage and horizontal stabilizer resting on a flat surface, align the horizontal stabilizer by measuring from fixed points on the wing to the outside of the trailing edge tip of the horizontal stabilizer. Be sure that the trailing edge of the horizontal stabilizer stays on its center mark.

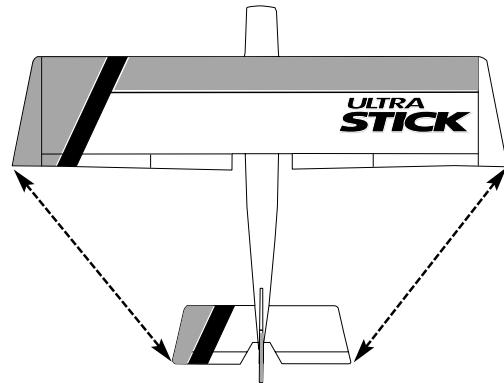

Step 5. Adjust the stabilizer until you have an equal distance on both the right and left sides of the stabilizer to the wing.

Step 6. When you're satisfied with the alignment of the horizontal stabilizer to the wing, carefully mark the position with a pencil at the junction where the horizontal stabilizer meets the fuselage. The pencil should leave a slight indentation in the covering.



Section 5:

Installing the Horizontal Stabilizer

CONTINUED

Step 7. Remove the horizontal stabilizer from the fuselage and using a sharp hobby knife and a straight edge, carefully trim away the covering approximately 1/16 " inside the lines you just marked.

Caution: It's extremely important that you do not press hard enough to cut into the wood structure as doing so could weaken the horizontal stabilizer.



Step 8. Install the wing onto the fuselage. With the fuselage and horizontal stabilizer together on a flat surface, check to be sure the wing and horizontal stabilizer are parallel with each other. If adjustments to the horizontal stabilizer saddle are necessary because the wing and stabilizer are not parallel, carefully sand the horizontal stabilizer saddle to adjust if necessary. Be absolutely sure that the fuse and stabilizer are on a flat surface and the wing is installed correctly before removing any material from the saddle area.

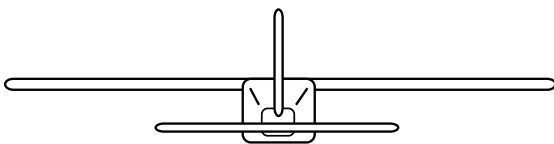

Step 9. Mix approximately 1/2 ounce (minimum) of 30-minute epoxy to install the horizontal stabilizer to the fuselage. Using an epoxy brush or mixing stick, spread the epoxy onto the top of the horizontal stabilizer where it comes into contact with the fuselage. Coat the stabilizer saddle area of the fuselage.



Note: Be sure when joining the horizontal stabilizer to the fuselage that they are assembled on a firm, flat surface and that they are level with each other.

Step 10. Lay the horizontal stabilizer onto a flat surface and position the fuselage onto it, making sure it's centered and aligned as in Steps 3 and 4. Reference the bare wood you just exposed to re-align the stabilizer. Place a heavy object (one that won't damage the fuselage structure) on top of the fuselage to press the stabilizer and fuselage together.



Step 11. Wipe off any excess epoxy using a paper towel and rubbing alcohol. Allow the epoxy to cure fully before proceeding to the next step.

Section 6:

Installing the Vertical Stabilizer (Fin)

Items Needed

Parts Needed

Vertical stabilizer
Fuselage

Tools and Adhesives Needed

Paper towels	Hobby knife
90-degree triangle	Pencil
Epoxy brush	Masking tape
Mixing stick	Rubbing alcohol
30-minute epoxy	

Step 1. On the rear of the fuselage a slot is precut in the wood structure for the vertical stabilizer. Using a sharp hobby knife cut away the covering on the top rear of the fuselage where the vertical stabilizer will insert.



Step 2. Remove the rudder and hinges from the vertical stabilizer if you have not already done so. The rudder will be hinged to the vertical stabilizer later.

Step 3. Insert the vertical stabilizer into the slot in the top of the fuselage and make sure it's firmly seated against the top of the fuselage. Check that the rear of the vertical stabilizer (where the hinge slots are located) is aligned with the rear of the fuselage.



Step 4. Use a pencil to carefully mark the position of the vertical stabilizer on both sides where it exits the fuselage. Also mark onto the fuselage where it contacts. The pencil should leave a slight indentation in the covering.



Step 5. Remove the vertical stabilizer. Using a sharp hobby knife and straightedge, carefully cut away the covering on the vertical fin and fuselage approximately 1/16" inside the lines marked in Step 4.

Caution: It's very important that you do not press hard enough to cut into the wood structure, as doing so could weaken the vertical stabilizer.



Section 6:

Installing the Vertical Stabilizer (Fin)

CONTINUED

Step 6. Mix approximately 1/4 ounce of 30-minute epoxy and apply it to the vertical stabilizer where it comes into contact with the fuselage. Also apply epoxy to the base of the vertical stabilizer where it comes in contact with the fuselage.

Important: It is essential the vertical stabilizer base be epoxied to the inside the fuselage to provide adequate strength. Be sure to use plenty of epoxy!



Step 7. Insert the fin into the fuselage and wipe away any excess epoxy using a paper towel and rubbing alcohol.

Step 8. Using a 90-degree triangle, make sure the fin is perpendicular to the horizontal stabilizer. Use masking tape to hold the vertical stabilizer in place until the epoxy cures.

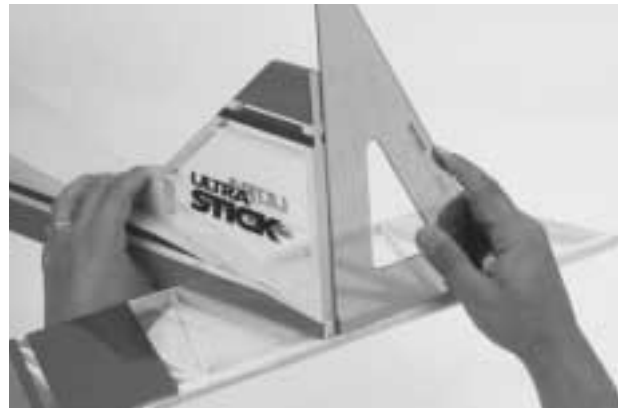

Section 7:

Installing the Rudder and Tail Wheel Assembly

Items Needed

Parts Needed

Fuselage
Rudder
Hinges
Tail wheel wire assembly
Tail wheel
Tail wheel collar

Tools and Adhesives Needed

Drill	Paper towels
Drill Bits: 3/32 ", 1/16 "	30-minute epoxy
Hobby knife	Rubbing alcohol
Felt-tipped pen	Mixing stick
Toothpicks (optional)	Threadlock Z-42
Thin CA glue	Petroleum jelly or oil
Needle-nose pliers	Masking tape
CA remover/debonder	Keyhole saw blade

Step 1. Trial fit the rudder on to the vertical fin with the hinges in place. Locate the tail wheel wire assembly and hold it up to the fuselage making sure the bottom of the nylon bushing is flush with the bottom of the horizontal stabilizer. Note where the wire rests in relation to the rudder. Using a felt-tipped pen, mark the position where the hole is to be drilled into the rudder. Also mark the location for the slot where the bushing tab will be epoxied into the back of the fuselage. This slot should be positioned centered on the fuselage tail.



Step 2. Remove the rudder from the vertical fin and use a 3/32" drill bit to drill the hole for the tail wheel wire. Drill into the exact center of the rudder where you marked in Step 1. It may be helpful to first drill a 1/16" pilot hole as a guide.



Step 3. Cut a slot and groove in the back of the fuselage where the tab of the tail wheel bushing will be epoxied. There are several methods to accomplish this; we used a Dremel cutting wheel to first cut a slot in the fuselage as marked in Step 1. Next use a keyhole saw blade to enlarge the opening for the tail wheel bushing.



Section 7:

Installing the Rudder and Tail Wheel Assembly

CONTINUED

Step 4. Trial fit the rudder and tail wheel assembly to the vertical fin. Note that the rudder will require trimming to allow clearance for the tail wheel wire/bushing. Mark the rudder and using a sharp hobby knife, trim back the rudder only a small amount and refit the rudder to the fin. Repeat this process until you achieve a perfect fit with virtually no gap between the vertical fin and rudder. Remove the rudder from the vertical fin.



Step 5. Reinstall the hinges in the vertical fin using T-pins to ensure the hinges are centered. The hinges will be CA'd in Step 7.



Step 6. Mix approximately 1/2 ounce of 30-minute epoxy and apply it to both the nylon bushing of the tail wheel assembly where it goes in the back of the fuselage and to the hole drilled in the rudder for the wire. A tooth pick applicator may be helpful in getting the epoxy into the hole. Install the rudder and tail wheel assembly to the vertical fin and fuselage and remove the T-pins. Make sure the rudder is positioned properly (up and down). Wipe away any excess epoxy with alcohol and paper towels. Allow the epoxy to completely cure before gluing the hinges in place.

Note: Do not get epoxy on the bushing where it contacts the rudder. The rudder must move freely on the bushing.



Step 7. After the epoxy has completely cured, apply thin CA to the hinges by first deflecting the rudder in one direction, saturating each hinge, and then repeat the process by deflecting the rudder in the opposite direction. Wipe away any excess CA by using a paper towel and CA remover/debonder. Allow the glue to completely cure.



Section 7:

Installing the Rudder and Tail Wheel Assembly

CONTINUED

Step 8. Once the CA has cured, check for security of the rudder by gently trying to pull the rudder from the fin. Also move the rudder several times left and right to "work in" the hinges.



Step 9. Slide the tail wheel onto the tail wheel wire. Next secure the wheel with the included wheel collar and set screw. Use blue Loctite 242 to secure the setscrew in place.

Note: The wheel must rotate freely with only a small amount of side play. It may be necessary to drill out the tail wheel slightly so the wheel can spin freely.



Section 8:

Hinging the Horizontal Stabilizer and Elevator

Items Needed

Parts Needed

Fuselage
Elevator
Hinges

Tools and Adhesives Needed

Thin CA glue
CA remover/debonder
Paper towels
T-pins

Step 1. Locate the elevator and hinges. Trial fit the elevator into the proper position on the horizontal stabilizer using the same hinging technique used in Section 1. Remember to remove the T-pins before applying the CA glue. Also, make sure the tail wheel is free to move its full range. You will also need to file a small notch in the elevator to clear the tail wheel wire.

Important: Do not remove more material than is necessary. Check to make sure there is sufficient elevator movement without any binding.



Step 2. With the elevator aligned (left and right), apply thin CA glue to the hinges on both sides. Wipe away any excess CA with CA remover/debonder and a paper towel.

Note: Try to maintain virtually no gap throughout the length of the elevator-to-horizontal stabilizer hinge line.



Step 3. After the hinges are dry, check to make sure they are securely in place. Try to pull the elevator from the horizontal stabilizer. Use care not to crush the structure.

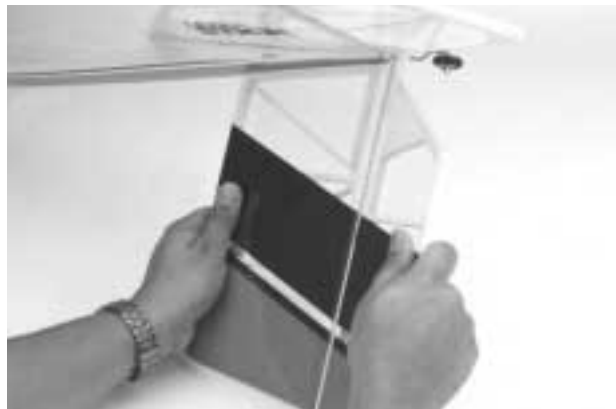

Step 4. Move the elevator up and down several times to "work-in" the hinges and check for proper movement.

Section 9:

Installing the Rudder and Elevator Control Horns

Items Needed

Parts Needed

Control horns (2)
Control horn backplates (2)
Control horn screws (6)
Fuselage

Tools and Adhesives Needed

Drill
Drill Bit: 1/16"
Felt-tipped pen/pencil
Phillips screwdriver (medium)
Ruler

Important: When installing the control horns, make sure the holes in the control horns, where the pushrod attaches, are directly in line with the control surface hinge line.

Step 2. Place the center of the control horn on the elevator at the mark made in the previous step. Mark the hole positions of the control horn with a felt-tipped pen or pencil.

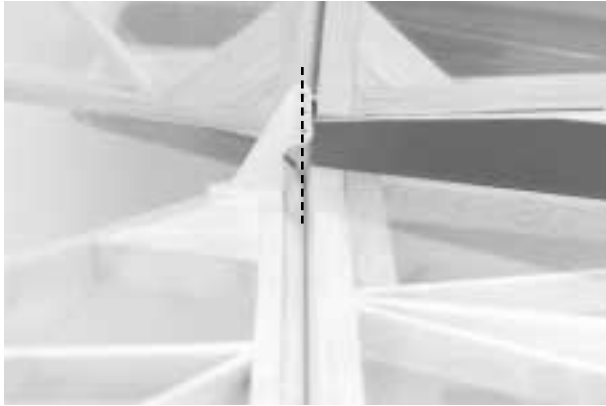

Step 1. To locate the elevator control horn position, measure over 1" from the fuselage on the top right side of the horizontal stabilizer. Mark the elevator as shown with a felt-tipped pen or a pencil. This mark will be the center of the elevator control horn location.

Step 3. Remove the control horn and drill 1/16" holes through the elevator as marked. Make sure to drill these holes parallel to each other to allow the back plate of the horn to fit properly.

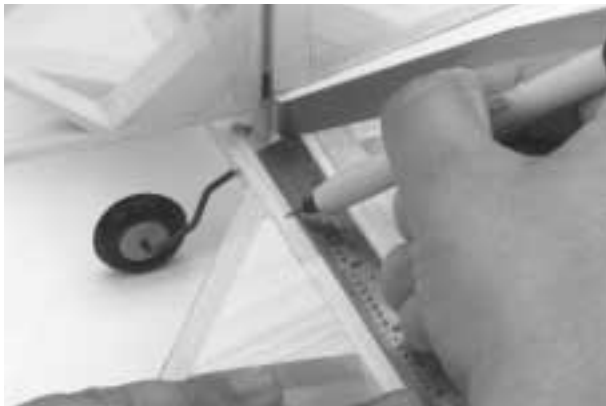

Section 9:

Installing the Rudder and Elevator Control Horns

CONTINUED

Step 4. Using the screws and backplate provided, attach the elevator control horn and fasten in place with a Phillips screwdriver.



Step 5. Measure 1" up from the bottom of the rudder on the left side. Mark the location with a felt-tipped pen or pencil. This mark will be the center of the rudder control horn.



Step 6. Center the control horn over the mark you've just made. Make sure the horn is positioned over the hinge line, just like you did for the elevator. Using a felt-tipped pen or pencil, mark the mounting hole locations onto the rudder.



Step 7. Drill these holes with a 1/16" drill bit and install the rudder control horn, using the screws and backplate provided.



Section 10:

Installing the Main Landing Gear

Items Needed

Parts Needed

Main landing gear
Fuselage
Landing gear axles with locknuts (2)
Wheel collar with screw (2)
Wheels, 2³/₄" (2)
Landing gear bolts (2)
Washers (2)

Tools and Adhesives Needed

Hobby knife
Phillips screwdriver
Moto-tool
Threadlock

Step 1. Attach the axles to the aluminum landing gear, using the locknuts provided. Slide on the wheel and use the wheel collar to secure the wheel on the axle.

Note: It is always a good idea to use Locktite 242 on the wheel collar setscrews to keep them from coming loose.



Note: You can use a Moto-tool to cut the extra length off the axle. Be very careful not to get the axle too hot during the cutting process or you may melt the wheel hub.



Step 2. Locate the three predrilled mounting holes in the bottom of the fuselage for mounting the landing gear. The blind nuts are also preinstalled from inside the fuselage. If the covering is over the holes, use a sharp hobby knife and carefully remove the covering over the predrilled holes.



Step 3. Bolt the landing gear onto the fuselage with the included hardware. Thread the mounting bolts into the preinstalled blind nuts and securely tighten.

Note: It is a good idea to use Locktite 242 on the landing gear mounting bolts.



Section 11:

Assembling the Fuel Tank

Items Needed

Parts Needed

Metal tubes (2)
Clunk (fuel pickup)
Fuel pickup tubing
Fuel tank

Metal caps (2)
Rubber stopper
3mm screw

Tools and Adhesives Needed

Hobby knife
Medium screwdriver

Step 1. Locate the tank parts.



Note: The stopper provided with the Ultra Stick™ 60 has three holes that are not completely through the stopper. You will only be using two holes: one for the fuel pickup and one for the fuel vent. Make sure not to open the third hole, as this will cause a fuel leak.

Step 2. Locate the rubber stopper. Insert the short brass fuel tube into one of the holes in the stopper so that an equal amount of tube extends from each side of the stopper. This tube will be the fuel tank pickup that provides fuel to the engine.



Step 3. Slide the smaller of the two caps over the tube on the smaller end of the rubber stopper. The small end will be inserted into the fuel tank. The larger cap is placed on the other side of the rubber stopper that makes the cap. Insert the 3mm screw through the large cap and rubber stopper. Loosely thread the screw into the small cap as shown.



Step 4. Locate the longer brass fuel tube and bend it using your fingers as shown. This will be the fuel tank vent tube.



Section 11:

Assembling the Fuel Tank

CONTINUED

Step 5. Slide the vent tube into one of the two remaining holes in the stopper from the tank (small cap) side.



Step 6. Locate the short piece of silicone fuel tubing and the fuel tank clunk. Install the clunk onto one end of the silicone tubing and the other end onto the brass fuel tank pickup tube (straight tube) in the stopper.



Step 7. Carefully insert the assembly into the fuel tank. Note the position of the vent tube. It must be at the top portion of the fuel tank to function properly. Also, it may be necessary to shorten the length of the fuel pickup tubing to make sure the clunk does not rub against the back of the fuel tank. You should be able to turn the tank upside down, which allows the clunk to freely drop to the top of the tank.



Step 8. Tighten the 3mm screw carefully — do not over tighten. This allows the rubber stopper to form a seal by being slightly compressed, thus sealing the fuel tank opening.

Important: Be sure to differentiate between the vent and the fuel pick-up tube. Once the tank is mounted inside the fuselage, it will be difficult to tell the tubes apart. We have included two different color pieces of fuel tubing to help you tell them apart. We suggest using the green tubing for the fuel line to the carburetor of your engine and the red tube for the vent tube.

Note: The fuel tank will be installed into the fuselage after the engine mount is installed.

Section 12:

Mounting the Engine

Items Needed

Parts Needed

Fuselage
Hangar 9™ nylon engine mount w/hardware
Engine
Assembled fuel tank
Protective foam (not included)
Throttle pushrod tube

Tools and Adhesives Needed

Drill
Drill Bits: 3/16", 1/8"
6-minute epoxy
Phillips screwdriver
Threadlock

Note: When the engine is properly mounted to the Ultra Stick™ 60, the distance from the firewall to the front of the engine drive washer should be 5" to 5 1/4".

Step 1. Locate the nylon engine mount rails and temporarily install the mounts using the four engine mount screws and washers as shown. Note that the engine is mounted with the cylinder head to the right of the fuselage.

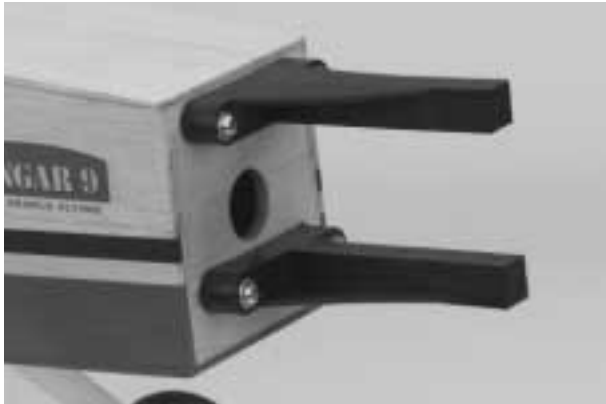

Step 2. Place your engine onto the installed mounting rails and measure the distance from the firewall to the engine drive washer (5" to 5 1/4"). Carefully mark the mounting hole locations for the engine as shown. Using a felt-tipped pen, mark the location where the throttle pushrod will come through the firewall. This will vary with engine type; you want a straight shot from the firewall to the throttle arm of the engine.



Step 3. Remove nylon engine mounting rails from the firewall and using a 3/16" drill bit, drill the mounting holes in the mount. Use caution to make sure you drill straight through the mount as not to cause any side load on the mounting screws when installed.



Section 12:

Mounting the Engine

CONTINUED

Step 4. Locate the throttle pushrod tube included with the kit. Drill a 1/8" hole in the firewall at the mark you made in Step 2. Mix a small amount of 6-minute epoxy and glue the pushrod tube through the firewall leaving approximately 1/8" protruding through the firewall. Allow the epoxy to cure before proceeding.

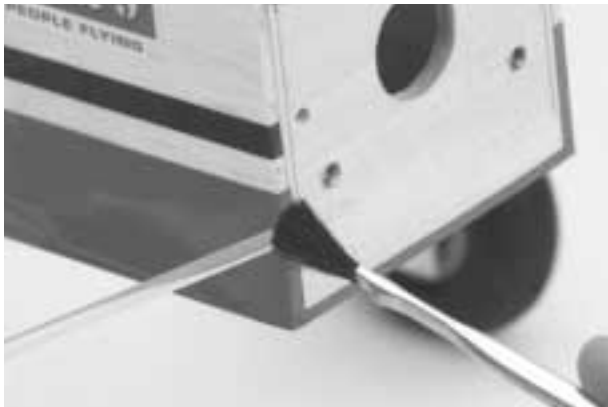
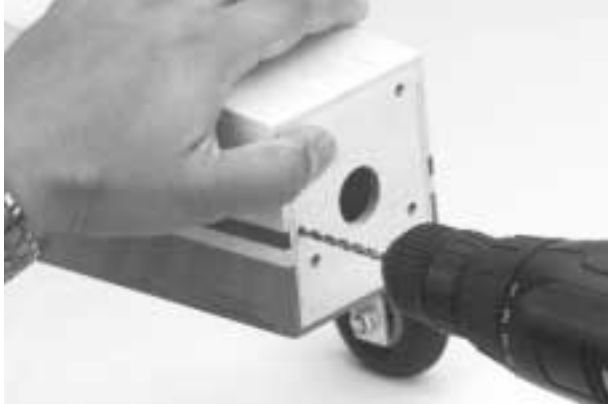

Step 5. Before installing your engine and engine mount, insert the fuel tank into the fuselage. The two pieces of fuel tubing should exit through the center hole in the firewall. Use foam (not included) under and behind the fuel tank and/or around the fuel tank to secure it in place.



Step 6. Using Loctite Z-42 on the engine mount screws, install the engine mount to the firewall. Mount the engine using the supplied hardware (four screws, washers, and locknuts).



Step 7. Install the fuel pick-up line to the carburetor. The fuel tank vent line will be installed onto your engine's muffler.



Section 13:

Installing the Radio System

Items Needed

Parts Needed

Radio system with 3 servos and hardware (not included)
Fuselage
Radio packing foam (not included)
Antenna tube (optional, not included)

Tools and Adhesives Needed

Medium Phillips screwdriver
Hobby knife
Drill
Drill Bit: 1/16"

Note: Before installing the servos in the servo tray, we suggest the servo leads be identified by marking masking tape with the appropriate letter to designate each servo ("T" = Throttle, "R" = Rudder, and "E" = Elevator).

Step 1. Install the rubber grommets and eyelets in three servos, per the instructions with your radio equipment. Position the servos in the fuselage servo tray as shown, noting that the elevator servo is positioned on the right side of the fuselage. Mark the location of the servo mounting screws, remove the servos, and drill pilot holes for the screws using a 1/16" drill bit. Screw the servos in place using the 12 servo screws included with the servos.

Hint: To strengthen the servo screw mounting holes, place a drop of thin CA on each hole and allow to dry before mounting the servos to the servo tray.

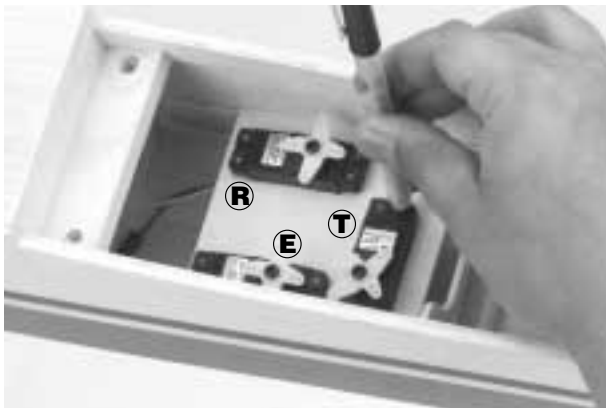

Step 2. Use radio packing foam (not included, available at your local hobby shop) when installing the receiver and battery.



Step 3. Be sure to attach the servo leads to the receiver prior to installing the receiver into the fuselage (refer to Radio Set-Up section). Route the antenna back through the fuselage using an antenna tube (not included) or route it outside the fuselage back to the stabilizer. If using an antenna tube, lightly tape the receiver antenna to the outside of tube (or route inside of tube) and route the antenna tube inside the AFT section of the fuselage. Be sure to avoid the elevator and rudder linkages.



Step 4. Wrap the receiver battery in foam and place it in the fuselage area forward of the servo tray and receiver. We suggest using layers of foam to hold the battery. Using a sharp hobby knife, cut a solid layer of foam the size of the compartment area that is in front of the servo tray. Cut another layer of foam that is identical in size, however, cut an opening the center that is the size of the battery pack. Cut another layer of foam identical in size to the compartment and place on top of the battery. Cut slits in the foam to allow the battery lead to exit the foam.

Section 13:

Installing the Radio System

CONTINUED

Step 5. The switch should be mounted on the left side of the fuselage, away from the exhaust of the engine.

Hint: Use the switch plate as a template.

Look inside the fuselage and pick a location to mount the switch in the opening of the fuselage side doubler. (Mount only through the fuselage sheeting, not through the ply doubler.)



Step 6. Using a 1/16" drill bit, drill two mounting holes for the switch as marked. Using a hobby knife, carefully cut out the opening for the switch between the screw holes.

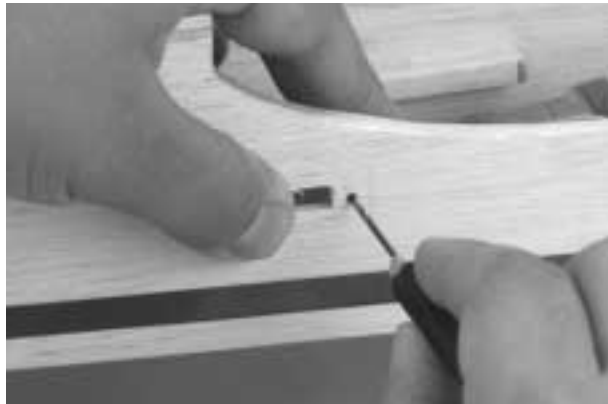

Step 7. Reposition the switch plate as shown and place the switch on the inside of the fuselage. Using the two screws supplied with the switch, attach the switch to the fuselage. Plug in the switch to the receiver/receiver battery.

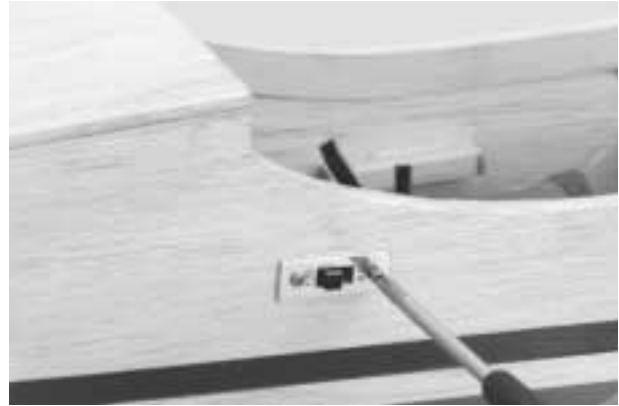

Section 14:

Installing the Aileron and/or Quad Flap Linkages

Items Needed

Parts Needed

Wing assembly w/servos installed
7 1/2" rods, threaded on one end
(2 for conventional wing, 4 for quad flaps)
Clevis (2 for conventional aileron, 4 for quad flaps)
Wire keepers (2 for conventional aileron, 4 for quad flaps)
Control horn (2 for conventional wing, 4 for quad flaps)
Control horn mounting screws
Clevis keepers (2 for conventional wing, 4 for quad flaps)

Tools and Adhesives Needed

Phillips screwdriver
Drill
Drill Bit: 1/16"
Felt-tipped pen
Thin CA glue (optional)

Step 1. Locate the short rods threaded on one end, clevis, and wire keepers. You will also need a control horn, control horn backplate, and mounting screws to mount the control horn to the control surface. Instructions will refer to construction of just one linkage and control horn. Assembly and installation for both ailerons and/or all four will follow this same sequence.

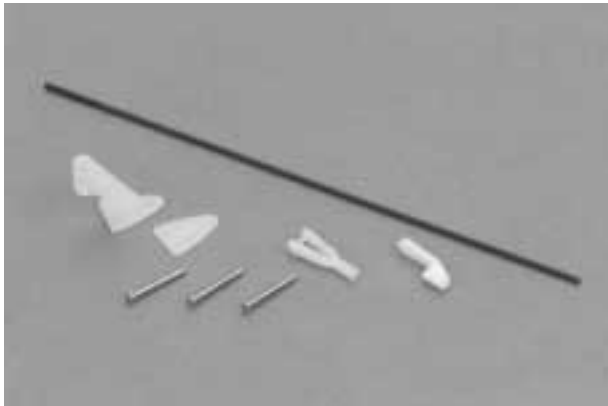

Step 2. Before assembly and mounting the linkages/control horns, it's a good idea to center the wing servos. Connect them to the receiver, turn on your transmitter, then the receiver. Once the servos have moved to their electrical center, you can position the servo control arm so that it will be approximately 90 degrees to the linkage when it's attached. Fine-tuning of the servo arm position can be done by adjusting the linkages in or out. It's important that the mechanical adjustments are made as closely as possible before attempting to make any electrical adjustments through the transmitter programs.

Important: The aileron/flaps servo arms should be positioned outboard toward the wing tips. Failure to do this can cause radio programming difficulties, resulting in the flaps or ailerons moving in the wrong direction.

Note: If you are using a Y-harness to connect servos to a receiver and if you are setting up a quad/flap configuration, refer to the "Radio Set-Up" section of this manual for further instruction on position of the servo control arms.

Step 2

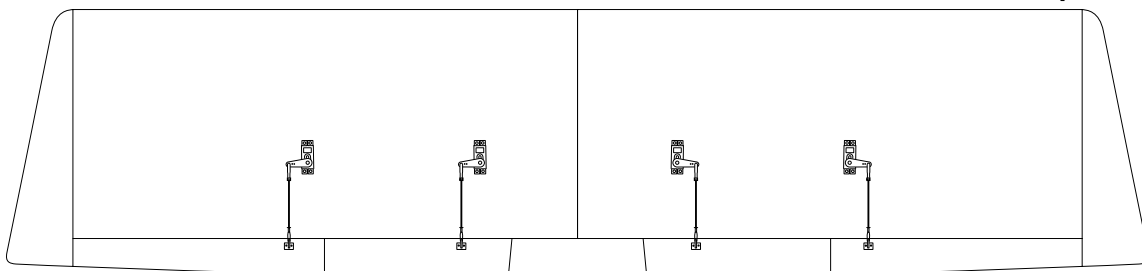

Section 14:

Installing the Aileron and/or Quad Flap Linkages

CONTINUED

Step 3. The control horn should be positioned so the holes the clevis connects into are over the hinge line of the control surface.



Step 4. Once satisfied with the horn location, (it should be a straight line from the servo arm to the horn), mark the location with a felt-tipped pen.



Step 5. Using a 1/16" drill bit, drill the screw holes for mounting the control horn. Use caution to drill straight through at a 90-degree angle to the control surface.



Step 6. Attach the control horn to the aileron (flap) using the screws and the control horn backplate. Be careful not to accidentally puncture the covering with the screwdriver.

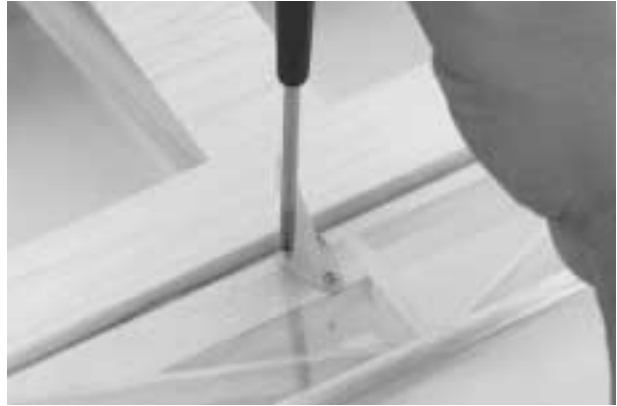

Step 7. Thread a 2-56 clevis on the threaded end of the control rod. Screw the clevis on a minimum of 7-10 turns. Install the clevis with wire on the control horn into the third hole from the mounting base. Be sure to install the clevis keeper (fuel tubing) over the clevis.



Section 14:

Installing the Aileron and/or Quad Flap Linkages

CONTINUED

Step 8. With the linkage attached to the control horn, center the control surface and hold the linkage wire directly over the electronically centered servo arm. Place a mark on the rod directly over the hole (second hole from the end of arm) in the servo control arm that it will connect to.



Step 9. Remove the clevis from the control horn. Make a 90-degree bend in the rod at the marked location and cut off the excess rod, leaving 5/16" of rod past the 90-degree bend.



Step 10. Attach a wire keeper to the end of the rod with the 90-degree bend. Insert the 90-degree bend through the second hole from the end of the servo arm and install the end of the wire keeper over the end of the wire. Install the clevis back onto the control horn. Be sure to slide on the silicon clevis keeper onto the end of the clevis.



Step 11. Repeat the process for the remainder of the aileron/flaps linkages.

Section 15:

Installing the Rudder, Elevator, and Throttle Pushrod

Items Needed

Parts Needed

Fuselage
30" pushrod wire, 2-56 threaded on one end (2)
19 1/2" pushrod wire, 1.5mm
Control horn (2)

Wire keeper (2)
Clevis (2)
Easy connector
Clevis keeper (2)

Tools and Adhesives Needed

Felt-tipped pen/pencil
Hobby knife
Needle-nose/Z-bend pliers

Step 1. Locate one of the long 30" pushrod wires threaded on one end, a 2-56 clevis, wire keeper, and a clevis keeper. The rudder and elevator pushrods are made using these parts shown below. The throttle linkage will be made from the shorter 19 1/2" rod.

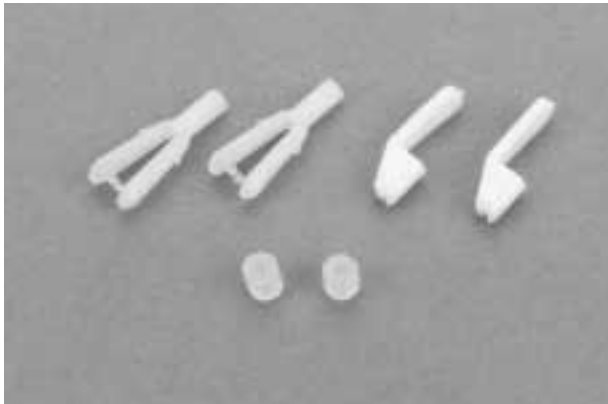
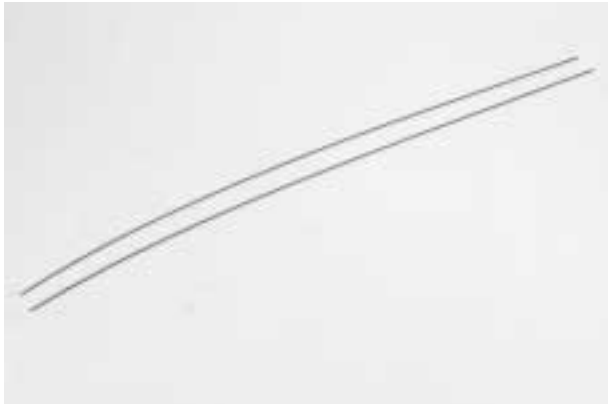

Step 2. Note that the pushrod wire guide tubes are preinstalled in the fuselage. On the aft end of the fuselage find the pushrod exits for the rudder and elevator pushrod. Using your hobby knife, carefully cut away the covering over the pushrod exit on the top left side of the fuselage next to the vertical stabilizer and the opening on the right side of the fuselage where the elevator pushrod will exit. Be careful not to cut the pushrod guide tube.



Step 3. Insert one of the 30" pushrod wires through the guide tube with the threads exiting the tube at the aft end of the fuselage. Screw on a clevis 7-10 turns and snap it onto the control horn.



Section 15:

Installing the Rudder, Elevator, and Throttle Pushrod

CONTINUED

Step 4. With the clevis attached to the control horn, center the control surface and hold the pushrod wire directly over the electronically centered servo arm. Place a mark on the rod directly over the hole (second hole from the end of arm) in the servo control arm it will connect to.



Step 5. Remove the clevis and slide the pushrod wire out of the guide tube. Make a 90-degree bend in the rod at the location you just marked and cut off the rod leaving 5/16" extending out from the 90-degree bend.



Step 6. Attach a wire keeper to the end of the rod with the 90-degree bend you just made. Insert the threaded end of the pushrod wire through the wire guide tube from the wing saddle opening of the fuselage. Install the 90-degree bend through the second hole from the end of the servo arm and install the end of the wire keeper over the end of the wire.



Step 7. Install the clevis back onto the pushrod wire and connect it to the control horn. Be sure to slide the silicone clevis keeper onto the end of the clevis before attaching the clevis to the control horn. After the clevis is attached to the control horn, slide the clevis keeper onto the end of the clevis to insure it will not prematurely open.



Step 8. Repeat the process for either the rudder or elevator, whichever one you have not done.

Section 15:

Installing the Rudder, Elevator, and Throttle Pushrod

CONTINUED

Installing the Throttle Pushrod

The sequence to install the throttle pushrod in this manual is for most four-stroke engines. Installation may vary depending on the type/brand of engine you use to power your Ultra Stick™ 60.

Step 9. Locate the smaller 1.5mm, 19¹/₂" pushrod and thread a clevis onto the threaded end. Insert the rod into the throttle pushrod tube previously installed.



Step 10. Install the easy connector to the throttle servo arm by inserting the bottom post through the second hole from the end in the throttle arm. Install the snap washer on the easy connector stem securing it to the arm.



Step 11. Connect the clevis end of the pushrod to the throttle arm.



Step 12. Turn on your radio system and center your transmitter's throttle stick and trim and center your throttle servo arm. Put the throttle arm of your engine to the 1/2-open/closed position.

Step 13. With your radio system on, the throttle controls centered, and throttle arm in the 1/2 open/closed position, secure the throttle pushrod wire to the easy connector by tightening the screw in the top of the connector to the pushrod wire. Trim off the excess wire.



Section 16:

Control Throw Recommendations

The following control throw recommendations offer positive response and are a good place to begin setting up the aircraft. After you have become more familiar with the flight characteristics of the Ultra Stick 60, adjust the control throws to meet your flying style.

Aileron

Low Rate

3/4" Up, 3/4" Down

High Rate

1 1/4" Up, 1 1/4" Down (both wing types)

Elevator

Low Rate

1" Up, 1" Down

High Rate

1 1/2" Up, 1 1/2" Down

Rudder

Low Rate

2 1/2" Right, 2 1/2" Left

High Rate

4" Right, 4" Left

Flaps

1 1/2" Down

Section 17:

Balancing the Ultra Stick 60

An important part of preparing the aircraft for flight is properly balancing the model. This is especially important when various engines are mounted.

Caution: Do not inadvertently skip this step!!

The recommended Center of Gravity (C.G.) location for the Ultra Stick 60 is 4 1/8" behind the leading edge of the wing.

If necessary, move the battery pack or add weight to either the nose or the tail until the correct balance is achieved. Stick-on weights are available at your local hobby shop and work well for this purpose.

Section 18:

Quad Flaps

CONTINUED

The quad flap option allows your Ultra Stick™ 60 to perform in ways that are just not possible with the conventional ailerons-only setup. With the quad flaps and a computer radio, different wing configurations can be programmed to extend the flight performance envelope. It's also a great way to learn more about your computer radio. Some of these configurations include the following:

Crow

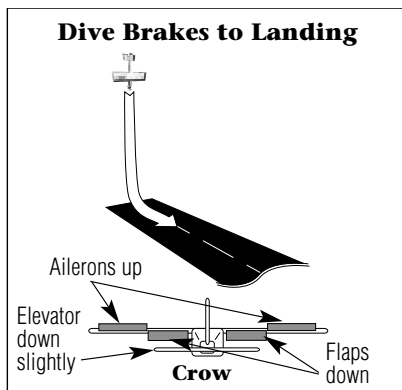

What is Crow?

Ailerons up, flaps down, elevator down

What does Crow do?

Crow is a very high drag configuration that is commonly used as dive brakes to prevent the airplane from building up speed during steep descents/dives. Crow is great for bleeding off excess airspeed and/or altitude, making short landings from high altitudes possible. With a little practice, it's easy to shoot landings in front of yourself from 500 feet or more of altitude and just 100 feet downwind from where you're standing. Just deploy Crow, push the nose straight down, and then pull elevator to level at about 10 feet and land right in front of yourself at a slow walking speed. The drag caused from Crow will prevent the Ultra Stick from gaining speed on the down line and, when the airplane is pulled to level, it will slow to a crawl within a short distance.

Another favorite maneuver that Crow allows is to fly nose high at very slow speeds with a high angle of attack (nearly 45°). Use full up elevator and jockey the throttle position to maintain level flight. This maneuver is sometimes called a Harrier. With Crow activated, the Ultra Stick 60 has reduced tendency to tip stall.

This is because the up ailerons at the tips of the wings (washout) help to keep the wing tips from stalling. Use the rudder only to steer the Ultra Stick during this maneuver and be careful if you turn off the Crow at these slow, high-angle-of-attack speeds, as there may not be enough airspeed to fly in the conventional mode. Anytime Crow is activated, the nose pitches up slightly, so it's recommended to mix some down elevator (about 1/4") whenever Crow is used.

First Flight Profile with Crow

On the first test flights, deploy the Crow at fairly high altitudes at various throttle settings to get a feel for what effects Crow has. You'll likely notice some reduction in roll control (ailerons) and the extra drag will drastically slow the airplane, no matter what throttle position or maneuver you're doing. Check to see if the nose pitches up or down and adjust the elevator mixing value after landing if necessary. Try some steep descents with Crow and notice that the Ultra Stick 60 builds up very little speed on the way down. Shoot some landings with Crow activated. You'll likely come up way short on your first few full Crow landings, so don't be surprised if you've got to add throttle. With a little practice, you'll confidently be able to do full-up elevator, tail-first landings.

On your first attempts to do the Harrier, start high. Deploy Crow and throttle back to idle; then, start adding up elevator smoothly. As full-up elevator is reached, increase the throttle just enough to maintain altitude. You can fly around in the nose-high attitude using rudder only to steer and, with some practice, you'll be doing Harrier landings with ease.

What to Watch For

In Crow, the wing tips are effectively washed out due to the fact that the up ailerons reduce the tendency to tip stall, making for very stable slow flight when the airplane is upright. When inverted or doing outside maneuvers, this washout effectively becomes wash-in (ailerons are down) and, if you're not careful, a tip stall can occur. Be careful when flying inverted or doing outside maneuvers with Crow deployed, as an unexpected tip stall could occur. Also, when doing high angle-of-attack flight or the Harrier at very slow speeds, it's recommended that you keep the Crow turned on.

Crow allows the Ultra Stick 60 to actually fly slower and at higher angles of attack than in the conventional configuration.

Section 18:

Quad Flaps

CONTINUED

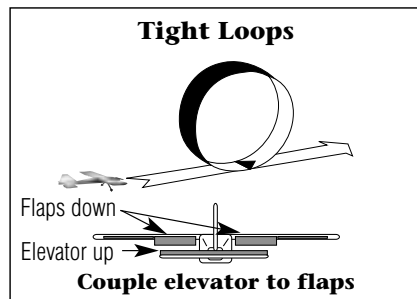

Elevator-to-Flaps

An up elevator command causes the flaps to go down, while a down elevator command causes the flaps to go up.

What does elevator-to-flap do?

Elevator-to-flap mixing causes more aggressive pitching when elevator is applied, making for tighter inside and outside loops. Using the recommended throws, the Ultra Stick™ 60 is capable of very tight 15-foot diameter loops.

First Flight Profile

It's a good idea to start up high then turn on the elevator-to-flap mixing to get accustomed to the increased pitch (elevator) sensitivity. You may find it necessary to increase the elevator expo to tame the aggressiveness around center. Now try some full up loops first with the mixing on and then off to see just how effective elevator-to-flaps can be. With practice, you can bring these tight loops right down to the deck and even do tight head-high outside loops.

Things to Watch For

The only real place you may run into trouble here is getting used to the increased pitch sensitivity and thus over-control the airplane. Just take it easy, staying at least two mistakes high until you're comfortable with the way the Ultra Stick 60 responds. Later you may want to try differing amounts of flap travel with elevator to see the effects.

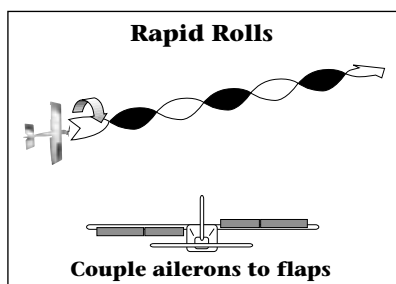

Aileron-to-Flaps

An aileron input causes the flaps to operate in the same direction as ailerons (i.e., a right aileron input causes the right aileron and right flap to go up and the left aileron and left flap to go down).

What does it do?

Aileron-to-flap mixing gives a more aggressive roll rate for doing rapid rolls. This mix also increases the rotation rate of snaps, spins, or any other maneuver that uses ailerons.

First Flight Profile

Start high and turn on the aileron-to-flap mix. Now do a couple of full-deflection, high-rate rolls and note the difference in roll rate. You should see about a 30% increase in roll speed. Now try a couple of snaps (full up, full right aileron, and full right rudder). You'll find snaps and spins tighter, faster, and more aggressive.

What to Watch For

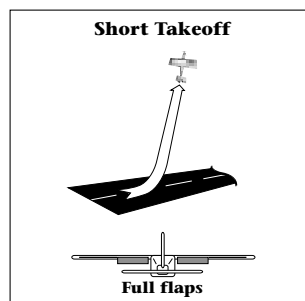

Be careful not to over-control the ailerons on your first attempts.

Short Takeoff Flaps

The flaps are set to a down position.

What does it do?

Short takeoff flaps create a high-lift wing that allows the Ultra Stick to do very short takeoffs, in some instances (from asphalt with a powerful engine) within the length of the fuselage.

First Flight Profile

After you have become comfortable with the flight characteristics of your Ultra Stick 60, it's time to give the short takeoff flaps a try. On the runway drop the flaps, then punch the throttle and hold some up elevator. Be ready for the Ultra Stick to break ground and head for the skies! It's important to release up elevator when the airplane breaks ground, then turn off the flaps to resume flights. On later flights try holding full up elevator to shorten the roll out even more.

What to Watch For

On your first flap takeoffs, you may be surprised at just how quickly the Ultra Stick 60 pops off the ground, especially with a strong engine. Be ready to release any up elevator quickly. Also, you'll notice that the flap causes the nose to pitch up a bit. We normally don't recommend mixing in elevator compensation (a bit of down elevator), as the intention of short takeoff flaps is to get off the ground in as short a distance as possible. Just turn off the flap shortly after takeoff.

Section 19:

Programming Guide

Following is a programming guide that provides step-by-step illustrations on how to program quad flap configurations for JR's XP652/642, XP783/347/388S, XP8103, and 10X/10SxII/10Sx radios, as well as for Futaba's 8-Channel 8UA/S radio.

Once you understand your computer radio, you'll soon discover that there are many other possible programming configurations (e.g., right rudder causes the right aileron to go up and the right flap to go down, causing a severe right yaw). We challenge you to try as many possibilities as you can think of — just remember, start high!

If you come up with any interesting ideas, we'd like to hear from you.

Note: If you have a computer radio that's not listed, please consult the instructions included with that radio or contact the radio's manufacturer for programming information.

JR XP652 or XP642	pages 46–51
JR XP783 or XP347 or XP388S	pages 52–59
JR XP8103	pages 60–67
JR 10X, 10SxII, 10Sx	pages 68–71
Futaba 8UA/S	pages 72–77

Section 19:

Programming Guide — JR XP652/642

Programming Your JR XP652/642 in 10 Easy Steps

JR's XP652 and XP642 feature the same base level of programming, so the procedure for setting up quad flaps for each radio is identical.

Note: Because these are 6-channel radios, it's necessary to use one reversed servo and an Y-harness to connect the flap servos in the wing. This allows the Crow, takeoff flaps, and elevator-to-flap configurations to be used. However, the aileron-to-flap configuration is only available with 7-channel or more computer radios.

First, it's important to plug each servo into the correct port in the receiver.

Note: When setting up a new aircraft, it's important to reset the programming to the factory defaults.

Note: One flap servo must be reversed.

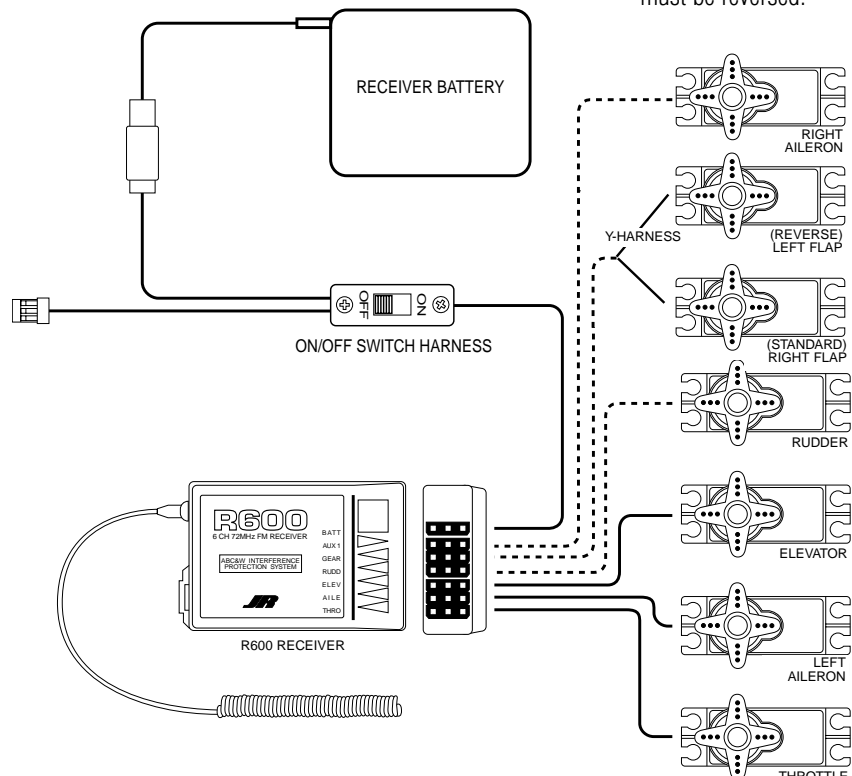

Section 19:

Programming Guide — JR XP652/642

CONTINUED

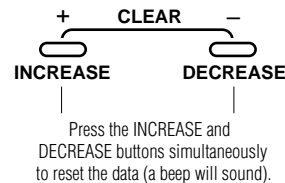
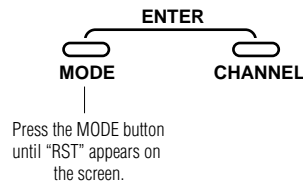
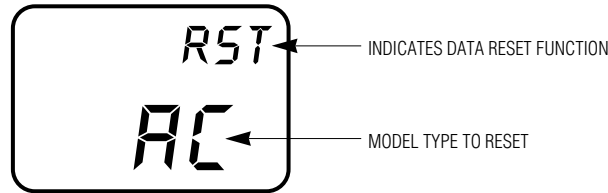

Step 1. Resetting the programming to factory defaults: Hold down both the *Mode* and *Channel* keys and turn on the radio to enter System Setup mode. Now press the *Mode* key

until "RST" appears on your screen. Now press the *Increase* and *Decrease* keys simultaneously to reset the programming to factory defaults.

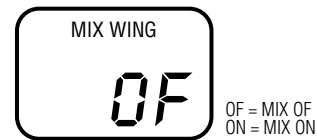
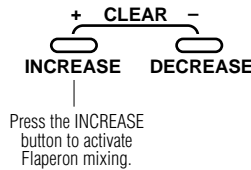
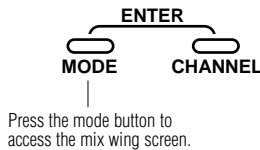

Step 2. Setting wing type to flaperons: In System Setup mode, press the *Mode* key until the "MIX WNG" screen appears.

(See above) Now press the *Increase* key until "FPR ON" appears on the screen.

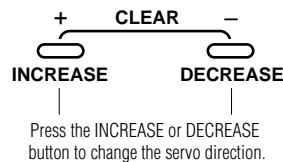
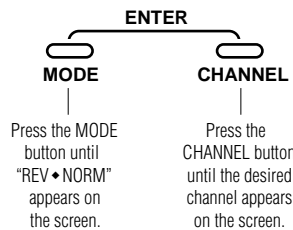
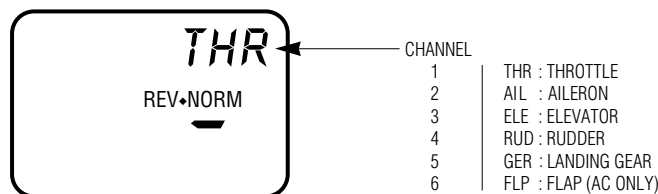

THR : THROTTLE
 AIL : AILERON LEFT
 ELE : ELEVATOR
 RUD : RUDDER
 GER : FLAPS
 FLP : AILERON RIGHT

Step 3. Set reversing switches: Turn the transmitter off then back on again. Now press the *Mode* and *Channel* key simultaneously to access the Function mode. Now press the *Mode* key to access the "REV-Norm" screen. Press the *Channel* key to access each channel, then check that the selected channel is moving in the correct direction (e.g., a right aileron command cause the right aileron to go up and the left aileron to go down).

To change the servo direction, press the *Increase* key. Check all channels and adjust as necessary.

Note: With the gear channel pulled toward you, the flaps should go down. With the flap switch pulled toward you, both ailerons should go up.

Section 19:

Programming Guide — JR XP652/642

CONTINUED

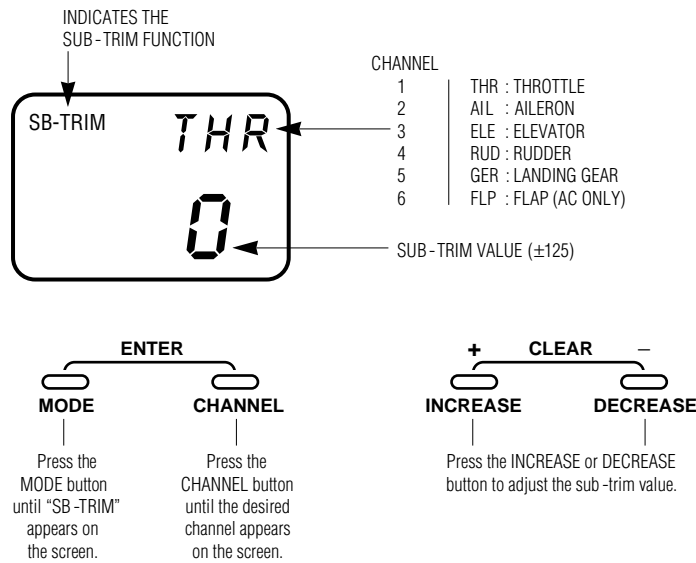

Step 4. Sub-trim: With the flap and gear switches in the rearward position and the mechanical trims centered, reposition any of the servo arms if necessary such that all control surfaces are at neutral or as close to neutral as possible. Now press the

Mode key to access the SB-TRM function. The *Channel* key allows you to select the desired channel, while the *Increase* and *Decrease* keys change the center position. Adjust the sub-trim as necessary until all control surfaces are neutral.

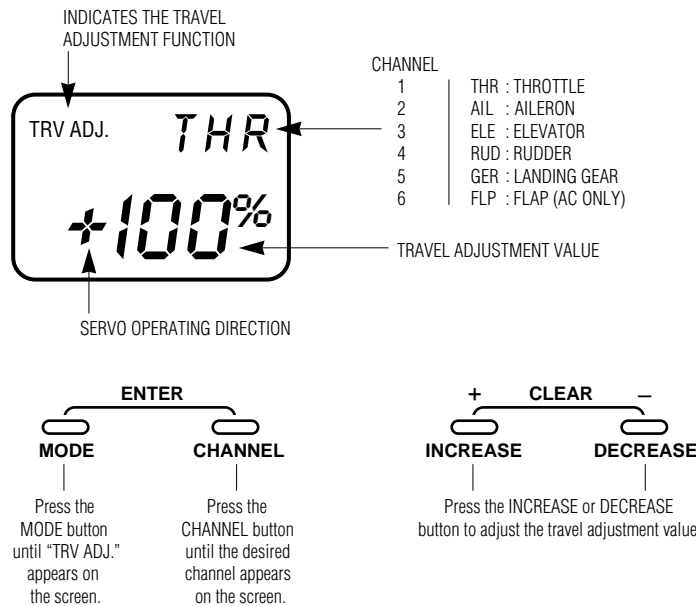

Step 5. Set travel adjust: Press the *Mode* key until "TRV ADJ." appears on your screen. Pressing the *CH* key will allow access to each channel. Adjust the travel of each channel to the following using the *Increase* or *Decrease* keys.

Important: Move the flap switch to the rearward position. Adjust the FL. Travel adjust to 0%. Reposition the servo arm so that the ailerons are neutral. If necessary, readjust the aileron sub trims slightly.

Note: To get the most performance out of your Ultra Stick™, long servo arms (1 inch) like JRPA215 are recommended. This provides for large control throws,

allowing for more aggressive maneuvers. To achieve the control throws listed at right, long servo arms may be necessary.

Note: Use the Dual Rate function to achieve these throws, see page 52.

- Throttle — Full throttle to full closed
- Aileron — 1 1/4" up, 1 1/4" down
- Elevator — 1 1/2" up, 1 1/2" down
- Rudder — 4" right, 4" left (rudder throws measured at bottom)
- Flaps — 1 1/2" down when the gear switch is pulled forward (adjust with GEAR channel travel adj.)

Section 19:

Programming Guide — JR XP652/642

CONTINUED

Note: The dual rate switch position is changed/accessed by setting the appropriate dual rate switch to the 0 or 1 positions.

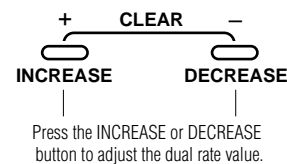
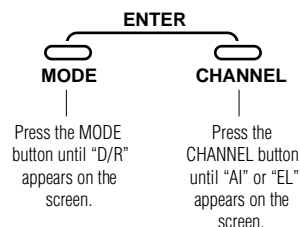
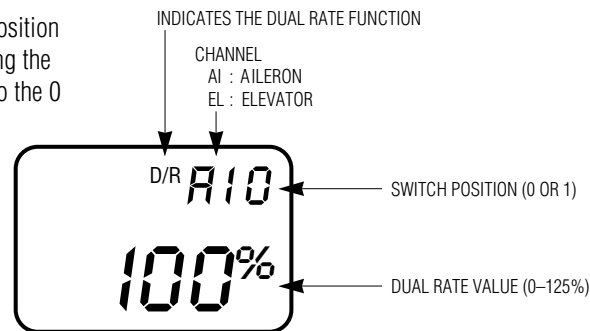

Step 6. Adjusting the dual rates: Press the *Mode* key until the dual rate screen appears. The *Channel* key allows you to select the aileron or elevator channel while the respective dual

rate switch allows you to select position 0 or 1. Adjust the high rate to 100% and the low rate to 50% using the *Increase* and *Decrease* keys. First flights should be attempted on low rates.

Note: The dual rate switch position is changed/accessed by setting the appropriate dual rate switch to the 0 or 1 positions.

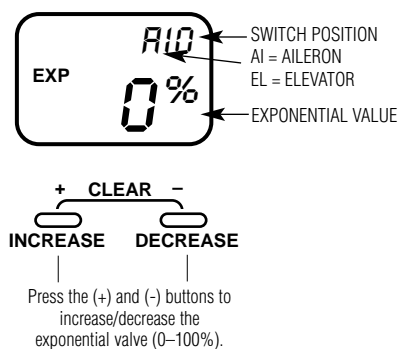
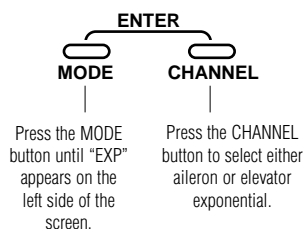

Step 7. Using exponential: Exponential is used to reduce the sensitivity of control around center while still providing full control authority when the control stick is fully deflected. Because the Ultra Stick uses large control throws, it's a good idea to give Expo a try, even if you've never used it before, to help prevent over-controlling. Press the *Mode* key until "EXP" appears on your screen. Use the *Channel* key to select the

aileron or elevator channel, then use the dual rate switch to access position 0 or 1. Separate expo values can be programmed for position 0 and 1. Press the *Increase* or *Decrease* keys to program the desired expo value for the selected channel and switch position. We recommend starting with an expo value of 25% on elevator and 30% on ailerons then, on subsequent flights, adjust the value until the desired control feel is achieved.

Section 19:

Programming Guide — JR XP652/642

CONTINUED

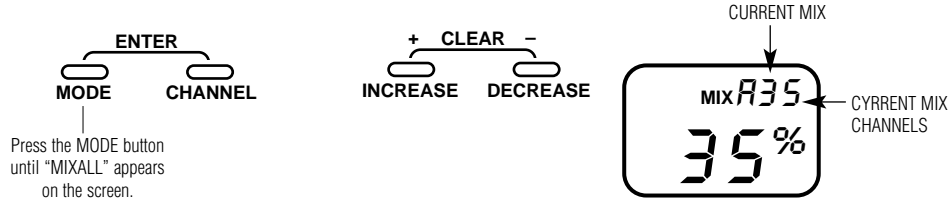

Step 8. Mixing elevator-to-flaps: Press the *Mode* key until the "MIX A11" screen appears. This is programmable MIX A and it allows you to mix any channel to any other channel or even to itself. Press the *Channel* key until the "MIX Ach" appears. This screen will allow you to select the master (elevator) and slave (in this case GEAR because GEAR is being used to deploy flaps). Elevator is channel 3, so press the *Increase* key until the screen reads "31." The first digit (3) is now the master channel (elevator). Now press the *Decrease* key until "35" appears in the screen. The second digit (5) is now the slave channel (gear, which we have Y-harnessed to flaps). This gives us an elevator-to-flap mix. Press the *Channel* key twice until "0%" appears on the screen. Now hold up elevator and press the *Increase* key until 35% is achieved. An up elevator command should result in

the flap going down. If the flaps go up instead, this 35% value needs to be -35%. Press the *Decrease* key until -35% is achieved. Now holding down elevator, press the *Increase* or *Decrease* key so that the flap goes up 35%.

Note: It's possible to assign this mix to be turned off/on using a selected switch. Press the *Channel* key until "MIX-ASW" appears. Pressing the *Increase* key will allow you to assign this mix:

- F1 = flap switch
- A = aileron dual rate switch
- E = elevator dual rate switch
- ON = always on.

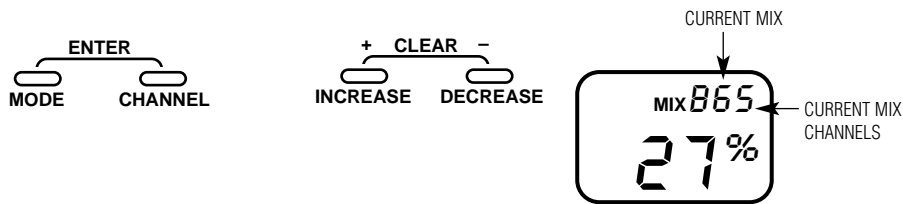

Step 9. Crow mixing: We've already done $\frac{1}{3}$ of the work in crow mixing above when we activated the flaperons and adjusted the ailerons to go up when the flap switch is pulled in Steps 2 and 5. Now we need to add down flaps and some down elevator. To get down flap when the flap switch is pulled, we're going to mix flap as master to gear as slave. Press the *Mode* key until "MIXB11" appears on the screen. Now press the *Channel* key to

access the "MIXBch" screen. Press the *Increase* key until "61" appears, then press the *Decrease* key until "65" appears in the screen. This programs channel 6 (flaps) as master and channel 5 (gear) as slave. Now press the *Channel* key until "MIX65 0%" appears on the screen. With the flap switch pulled forward, press the *Increase* key or *Decrease* key until the flaps go down $\frac{1}{2}$."

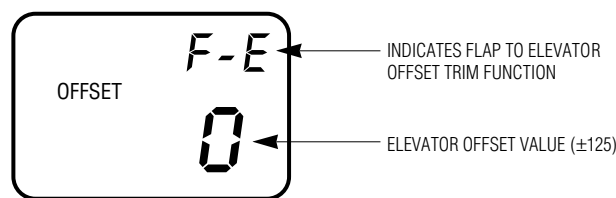

Step 10. Elevator Offset: To set the necessary down elevator with crow, press the *Mode* key until "OFFSET F-E" appears on

the screen. With the flap switch in the forward position, press the *Increase* or *Decrease* key until the elevator goes down $\frac{5}{8}$."

Section 19:

Programming Guide — JR XP652/642

CONTINUED

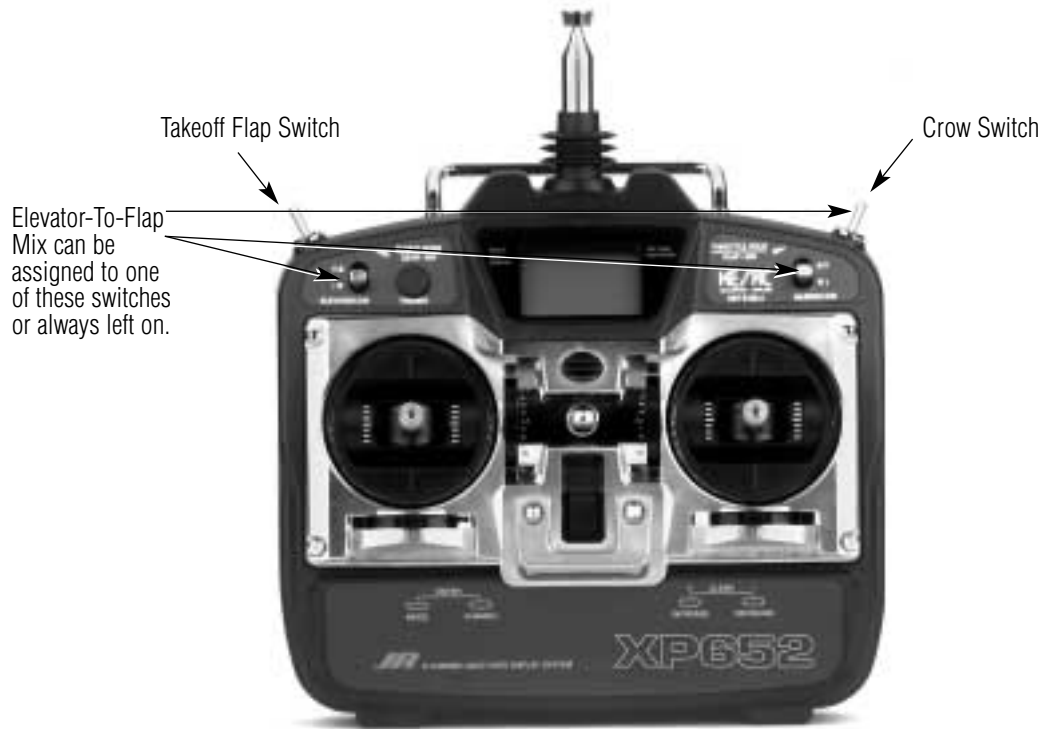

Note: The takeoff flaps should be retracted before using the Crow function to prevent any over-travel of the flap servos.

Section 19:

Programming Guide — JR XP783/XP347/XP388S

Programming Your JR XP783, XP347 and XP388S in 14 Easy Steps

JR's XP783, XP347 and XP388S all feature the same base level programming, so the procedure for setting up quad flaps for each radio is identical.

features in the glider programming that make quad flap easier to program and use. We strongly suggest using the GLID model type programming that's included in these radios.

Note: Most of the quad flap features needed for the Ultra Stick are already preprogrammed in the glider (referred to as GLID) software included in these three radios. While the Ultra Stick™ 60 is not a glider, there are several built-in

First, it's important to plug each servo into the correct port in the receiver.

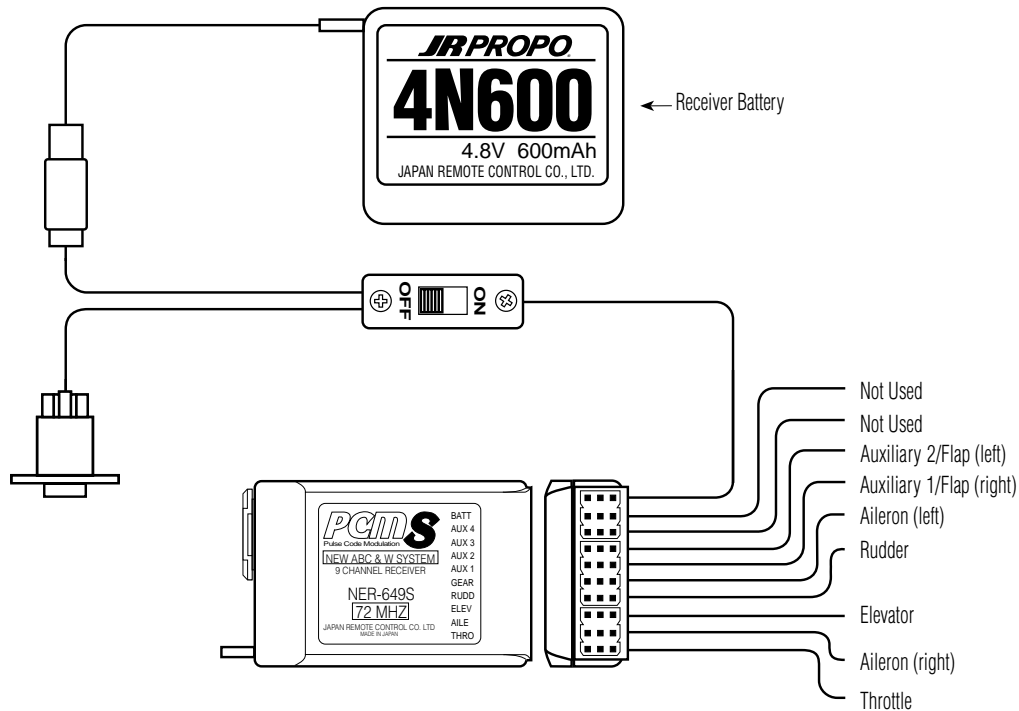

When setting up a new aircraft, it's important to reset the programming to the factory defaults.

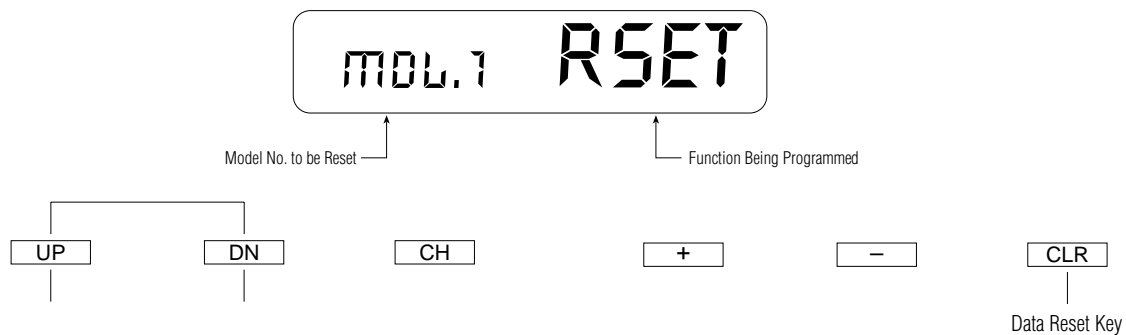

Step 1. Resetting the programming to factory defaults: Hold down both the *Up* and the *Down* keys simultaneously and turn on the radio to enter System Setup mode. Now press the

Up key until "RSET" (reset) appears on the screen. Pressing the *CLR* key will reset the programming to the factory defaults.

Section 19:

Programming Guide — JR XP783/XP347/XP388S

CONTINUED

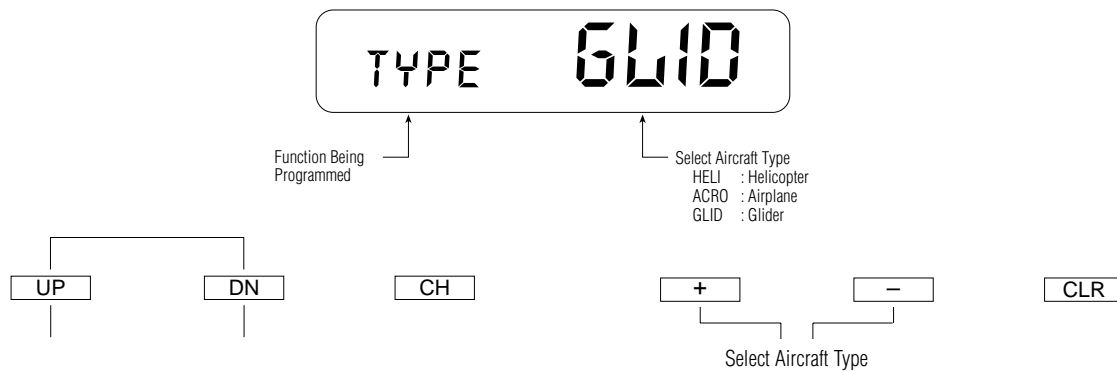

Step 2. Selecting model type (GLID): In System Setup mode, press the *Up* key until the "TYPE" screen appears.

Now press the (+) key until "GLID" appears on the screen.

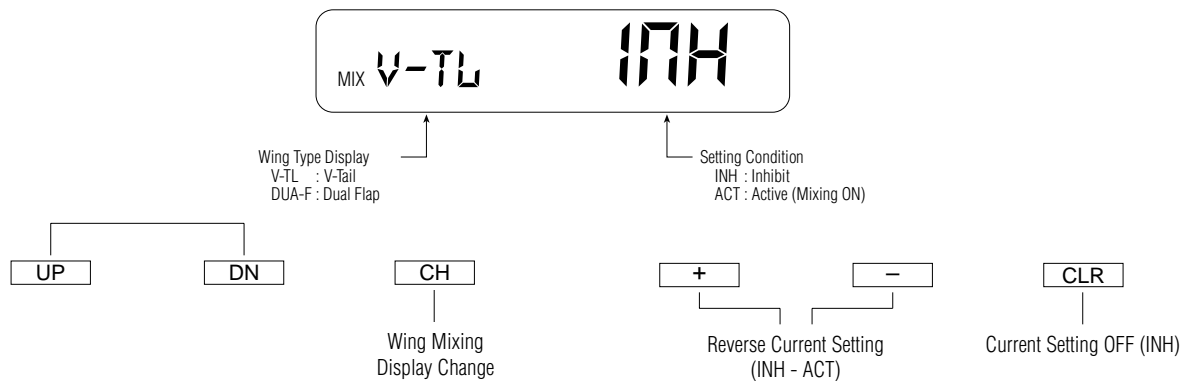

Step 3. Activating dual flap: In System Setup mode, press the *Up* key until the "V-TL INH" screen is displayed. Press the

CH key to access the mix "DUA.F" screen. Press the (+) key to activate (ACT) the dual flap function.

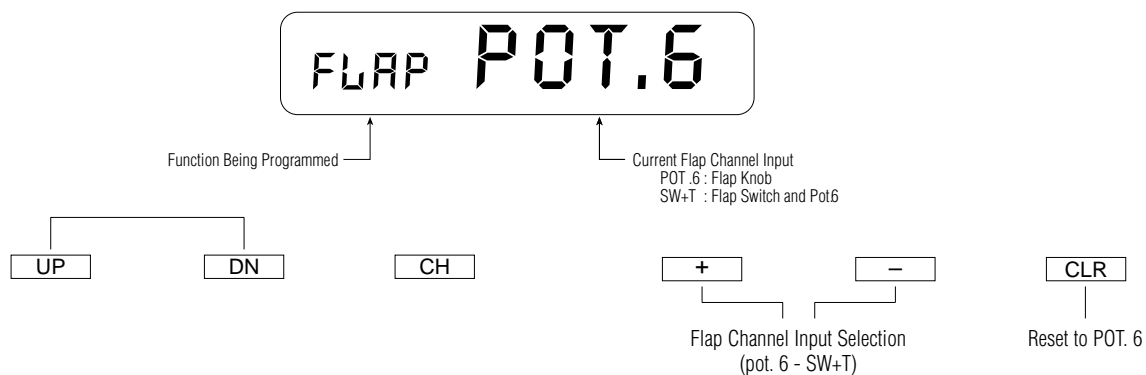

Step 4. Assigning the flaps to the flap switch: In System Setup mode, press the *Up* key until "FLAP POT.6" appears on the screen. Press the (+) key so that "SW+T" appears.

Note: With the JR X347 the flaps are automatically assigned to the switch. This step should be ignored.

Section 19:

Programming Guide — JR XP783/XP347/XP388S

CONTINUED

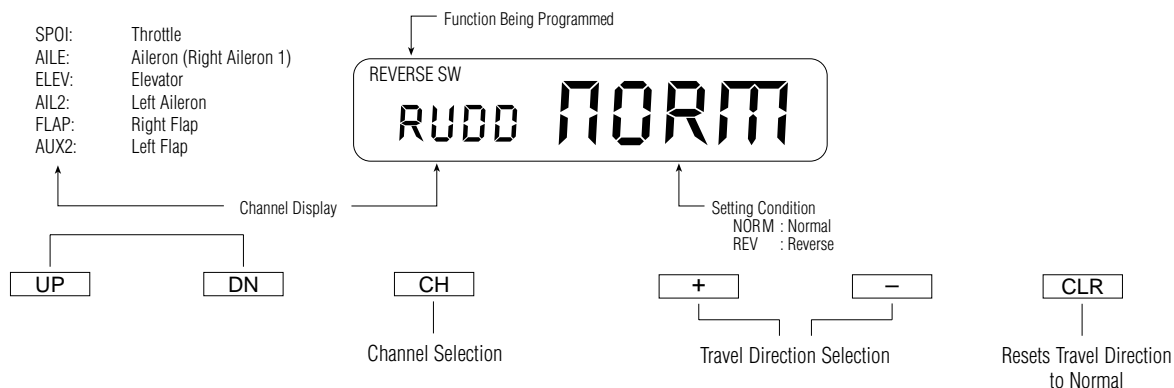

Step 5. Setting servo reversing: Turn the transmitter off, then back on again. Press the *Up* and *Down* keys simultaneously to access the Function mode. Press the *Up* key until the “REV” function appears on the screen. Press the *Channel* key to select each channel and check that the servo direction is operating correctly for each channel. To change the direction of the selected channel, press the (+) or (-) key. Check and adjust all channels as necessary.

Note: When the three-position flap switch is pulled down, the flap should come down. If they go up, reverse the direction of channel 6 (AUX 1) and/or 7 (AUX 2)

Note: Because the GLID model programming is being used, the transmitter refers to the throttle function as SPO1 or spoilers. Any time “SPO1” is displayed, it functions as throttle.

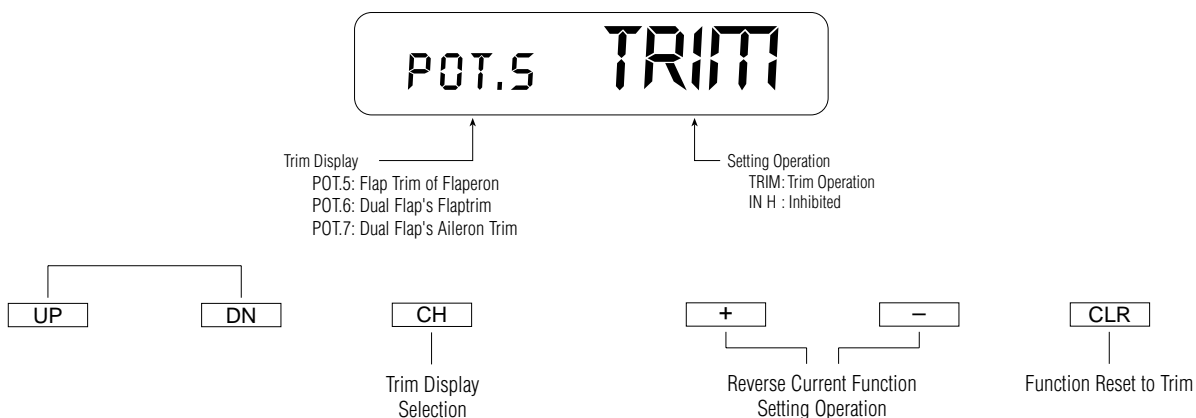

Step 6. Turning off the trim knobs: In Function mode, press the *Up* key until the “POT.5 TRIM” screen appears. Pressing the *CH* key will advance through the three available trim pots: 5, 6, and 7. Inhibit all three by pressing the (+) key

when each one is selected. This will prevent any unwanted control movement should the knobs be moved.

Note: With the 347, POT.6 is not available.

Section 19:

Programming Guide — JR XP783/XP347/XP388S

CONTINUED

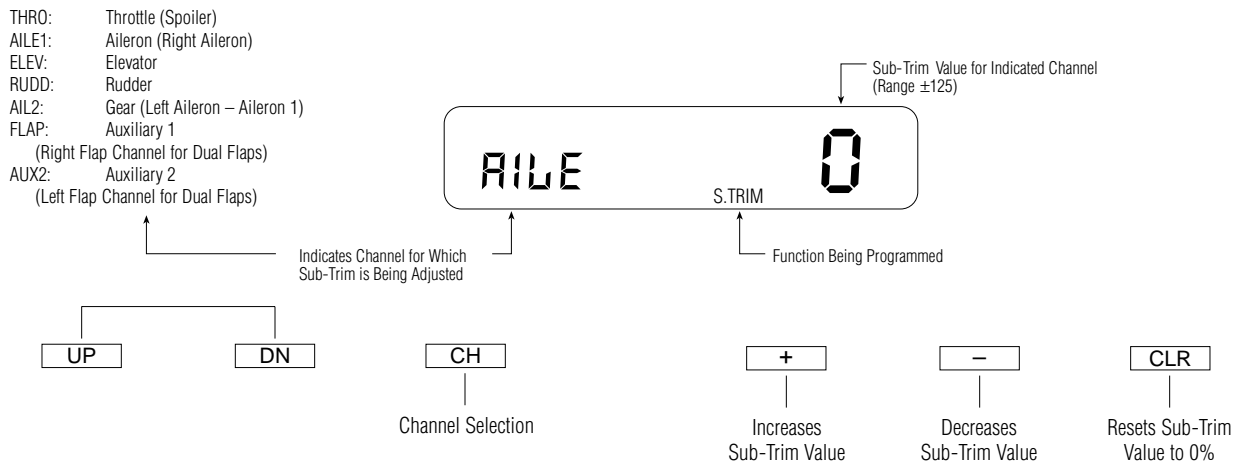

Step 7. Adjusting the sub trims: Turn on the transmitter and receiver and center the trims. Move the flap switch in the upper position. Now reposition all the servo arms so that all the control surfaces are as close as possible to their neutral

positions. In System Setup mode, press the *Up* key until the “S.TRIM” screen appears. Now press the *Channel* key to access the desired channel and press the (+) or (-) key to perfectly center each control surface.

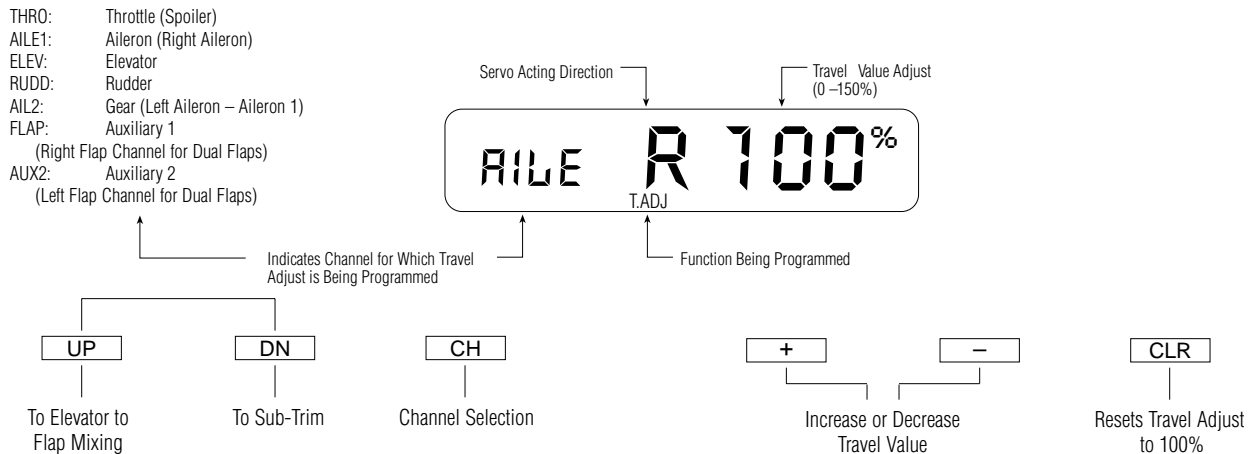

Note: The throttle is referred to as “SPOI” in the glider mode.

Step 8. Setting Travel Adjust: Press the *Up* key until the “T.ADJ” screen appears. Pressing the *CH* key will allow access to each channel. Adjust the travel of each channel to the throws shown below using the (+) or (-) key. Move the corresponding control stick in the desired direction to adjust the travel amount in that direction.

Note: To get the most performance out of your Ultra Stick™, long servo arms (1”) are recommended. This provides for large control throws for more aggressive maneuvers. To achieve the control throws listed below, long servo arms may be necessary.

- Note:** Adjust the right flap travel first, then the left flap.
- Throttle — Full open to full closed with trim (Referred to as “SPOI” in GLID mode)
 - Aileron — 1 1/4” up, 1 1/4” down
 - Elevator — 1 1/2” up, 1 1/2” down
 - Rudder — 4” right, 4” left
 - Full Flaps — 1 1/2” down

Section 19:

Programming Guide — JR XP783/XP347/XP388S

CONTINUED

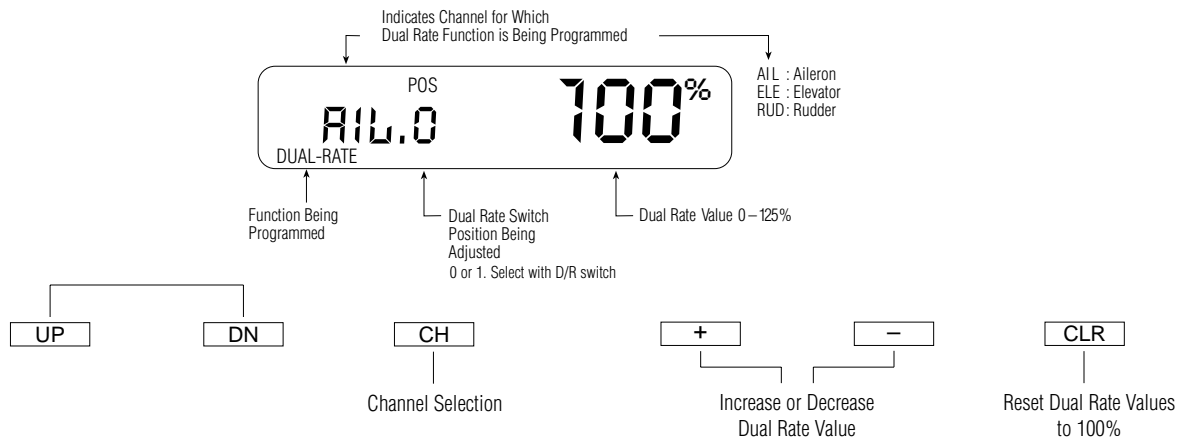

Step 9. Adjusting the dual rates: Press the *Up* key until the “DUAL-RATE” screen appears. The *CH* key allows the selection of the aileron, elevator or rudder channels, while the respective

dual rate switch allows you to select position 0 or 1. Adjust the high rate for each channel to 100% and the low rate to 50% using the (+) or (-) keys. First flights should be attempted using low rates.

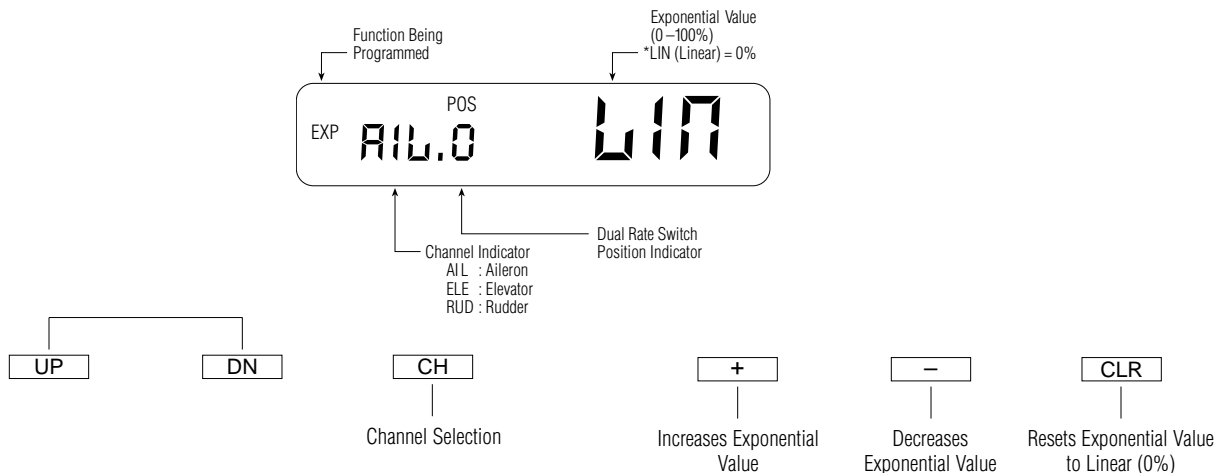

Step 10. Using exponential: Exponential is used to reduce the sensitivity of control around center while still providing full control authority when the control stick is fully deflected. Because the Ultra Stick™ 60 uses large control throws, it's a good idea to give expo a try, even if you've never used it before, to help prevent over-controlling. Press the *Up* key until the “EXP” screen appears.

Use the *Channel* key to select the aileron, elevator, or rudder channel, then use the corresponding dual rate switch to select position 0 or 1. Separate expo values can be programmed for position 0 and 1. We recommend an expo value of 30% on aileron and 25% on elevator and rudder for the first flights, then on subsequent flights, adjust the value until the desired control feel is achieved.

Section 19:

Programming Guide — JR XP783/XP347/XP388S

CONTINUED

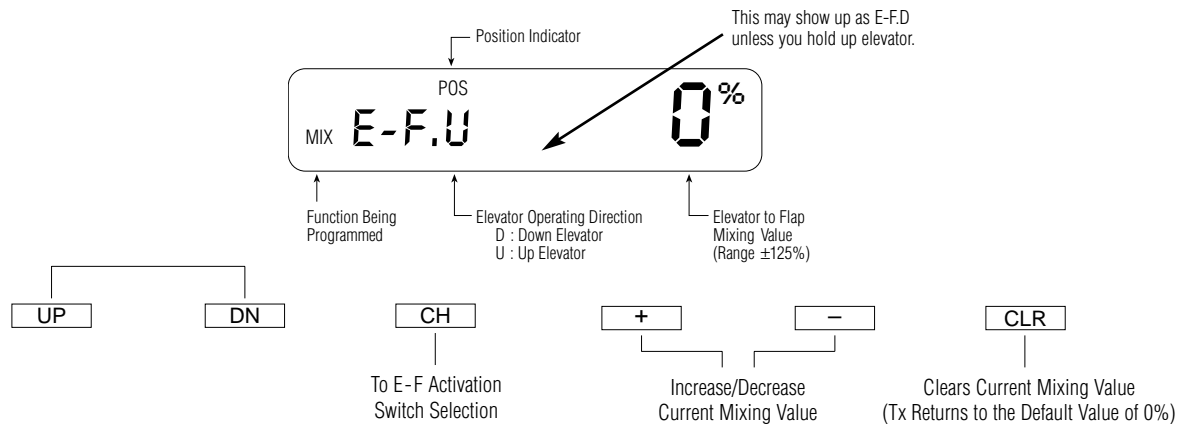

Step 11. Mixing elevator to flap: With the flap switch in the upper position, press the *Up* key until “MIX E-F.U” appears on your screen. This is the elevator-to-flap mix. Press the *CH* key to access the “EF: SW” screen. This screen allows you to select which switch will be used to turn on/off the elevator to flap mixing. Pressing the (+) key will select one of the following switches: MX SW = mix switch (located on the back right of the transmitter), F-DN = flap switch down, F-UP = flap switch up, or ON = always on. We suggest selecting the mix switch MXSW so the elevator-to-flap mix can be turned on and off independently of the flaps. After selecting MXSW, press the *CH* key to access the “MIX E-F.U” screen. With the Mix switch in the forward

position, hold up elevator and press the (+) key until a 35% value is achieved. Up should result in down flaps. If the flap goes up, then reverse the 35% value from a +35 to a -35 using the (-) key. Now hold down elevator and press the (+) key until 35% is achieved. The flaps should go up. Reverse the value if necessary until up elevator gives down flaps and down elevator give up flaps. Later you can experiment with more or less flap throw by changing this value. 35% is a good, safe place to start.

Note: The XP347 doesn't allow the elevator-to-flap mixing to be assigned to another switch and it remains on the flap up position.

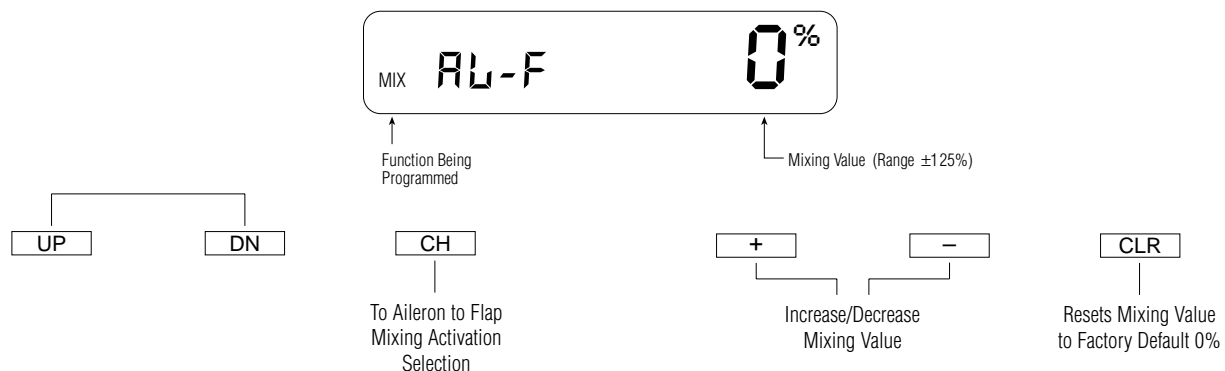

Step 12. Aileron to flap mixing: Press the *Up* key until the mix “AL-F” (aileron-to-flap mix) screen appears. Press the *CH* key to access the “MIX AF: SW” screen. This screen allows you to select which switch is used to turn on/off the aileron-to-flap mix. Pressing the (+) key will select one of the following switches: MXSW = mix switch located on the back right of the transmitter, F-DN = flap switch down, FU+D = flap switch up and down, and ON = always on. We recommend putting the aileron-to-flap mix on the mix switch so the mix can be turned off independently from the flaps. After selecting MXSW, press the *CH* key to return to the “MIX AL-F” screen. Now press the (+) key until +100%

value is reached. Now the flaps should move in unison in the same direction with the ailerons. If they move in opposite directions, press the (-) key until a -100% value is reached.

Note: When programmed, the aileron-to-flap mixing is always on when using an XP347.

Note: If “OFF” appears (where the mixing value is located in our example), move the flap switch to the opposite position. If “OFF” is still on the LCD, move the mixing switch to the opposite position.

Section 19:

Programming Guide — JR XP783/XP347/XP388S

CONTINUED

Step 13: Setting up Crow: Crow will be assigned to the flap switch and will be activated when the switch is in the down position. We've already set the flaps to the proper down position in

Step 7 travel adjust. Now we need to add the ailerons up 3/4" and the elevator down 5/8".

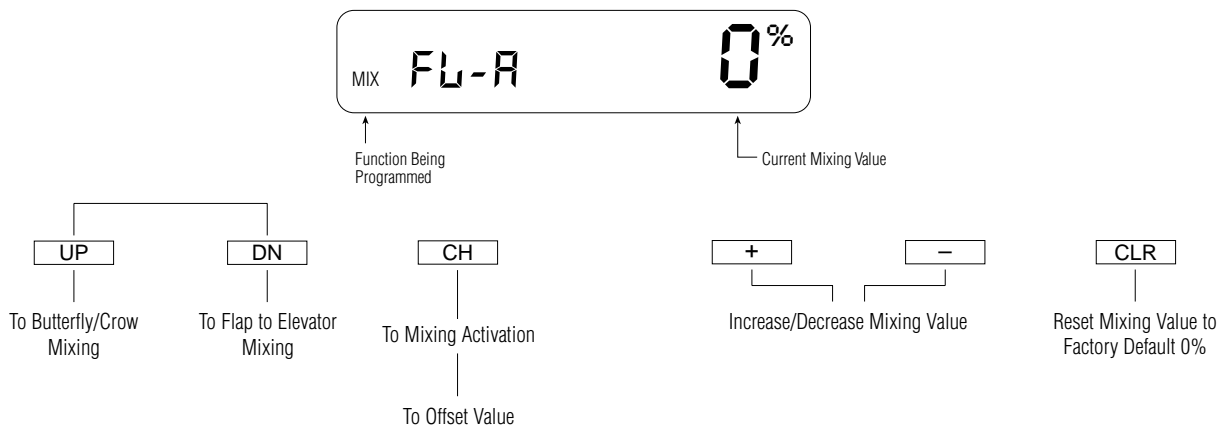

Step 14. Flap to ailerons mixing: Press the *Up* key until the "MIX FL-A" screen appears. Now press the *CH* key to access the "MIX FA: SW" screen (flap-to-aileron switch selection). Press the (+) key until "F-DN" (flap-down) appears on the screen. Now press the *CH* key twice to return to the "FL-A" screen. Move the flap switch to the down position. Next press

the (+) key until both the ailerons go up 3/4". If the ailerons go down, press the (-) key.

Note: With the XP347, the flap-to-aileron mix is always on when programmed.

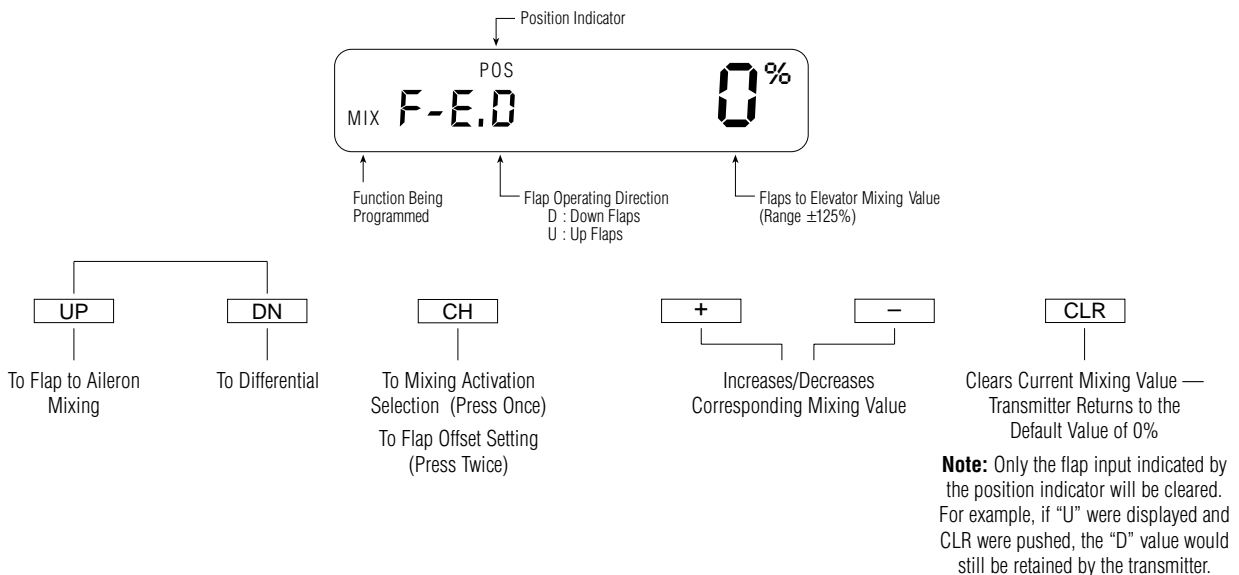

Step 15. Flap-to-elevator mixing: In Function mode, press the *Up* key until "MIX F-E" appears on the screen. Next press the *CH* key to access the "FE: SW" (flap-to-elevator switch selection) screen. Press the (+) key until "F-DN" (flap down) appears

on the screen. Now press the *CH* key twice to return to the "MIX F-E" screen. With the flap switch in the down position, press the (+) key until the elevator comes down 1/4". If the elevator goes up, use the (-) key to reverse this.

Section 19:

Programming Guide — JR XP783/XP347/XP388S

CONTINUED



Section 19:

Programming Guide — JR XP8103

Programming JR's XP8103 in 14 Easy Steps

First, it's important to plug each servo into the correct port in the receiver.

Note: Most of the quad flap features needed for the Ultra Stick are already preprogrammed in the glider (referred to as GLID) software included in the XP8103. While the Ultra Stick™ 60 is not a glider, there are several built-in features in the glider programming that make quad flap easier to program and use. We strongly suggest using the GLID model type programming that's included in these radios.

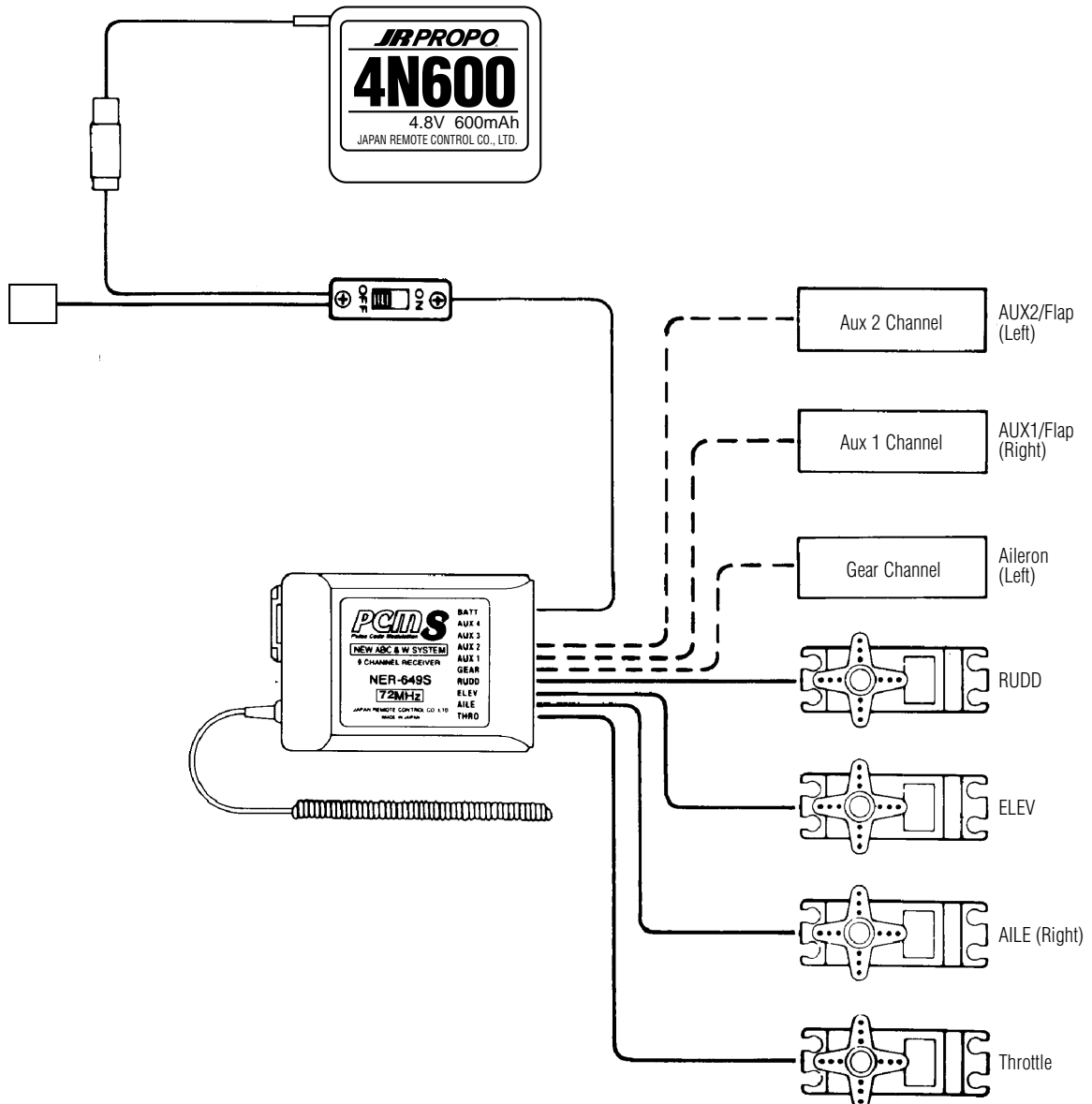

Section 19:

Programming Guide — JR XP8103

CONTINUED

Note: When setting up a new aircraft, it's important to reset the programming to the factory defaults.

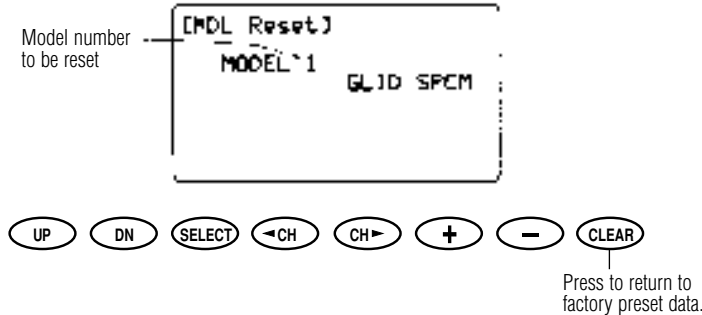

Step 1. Resetting the programming to factory defaults: Hold down both the *Up* and the *Down* keys and turn on the radio to enter System Setup mode. Now press the *Up* key three times to move the cursor to the "MDL Reset" menu (Model Reset).

Press the *Up* and *Down* keys simultaneously to enter the "MDL Reset" screen. Now press the *CLR* key to reset the programming to the factory defaults.

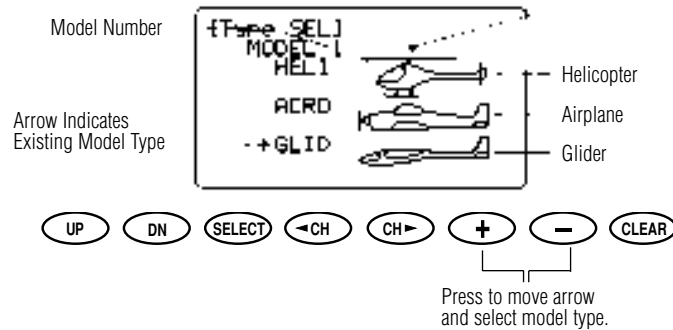

Step 2. Selecting model type (GLID): In System Setup mode, press the *Up* key until the "Type SEL" screen appears.

Now press the (+) key until the cursor points to "GLID" on the screen.

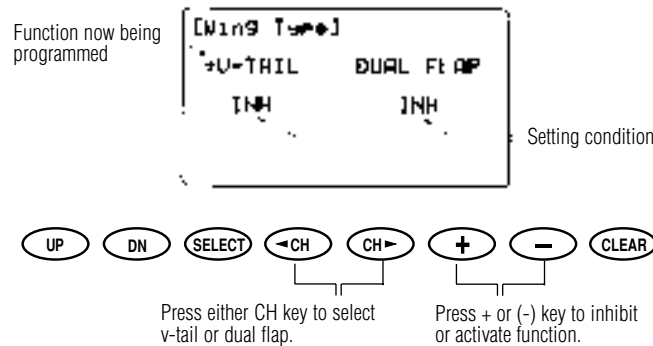

Step 3. Activating dual flap: In System Setup mode, press the *Up* key until the "Wing Type" screen is displayed. Press the

CH key to move the cursor to "DUAL FLAPS." Next press the (+) key to activate (ACT) the dual flap function.

Section 19:

Programming Guide — JR XP8103

CONTINUED

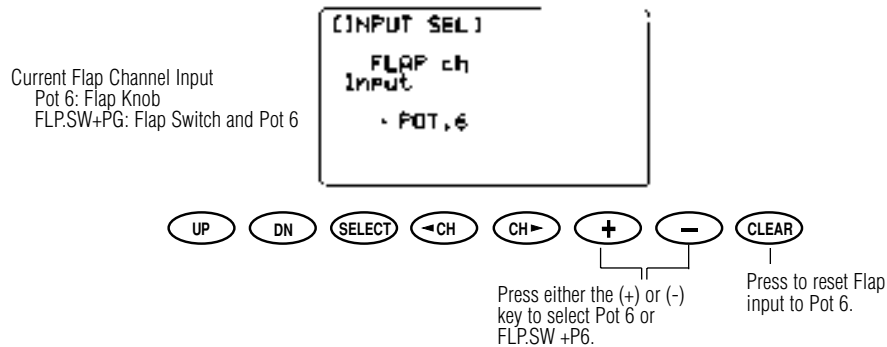

Step 4. Assigning the flaps to the flap switch: In System Setup *Mode* press the *Up* key until “Input Sel.” (Flap Input)

appears on the screen. Press the (+) key so that “FLP.SW+P6” appears in the lower screen.

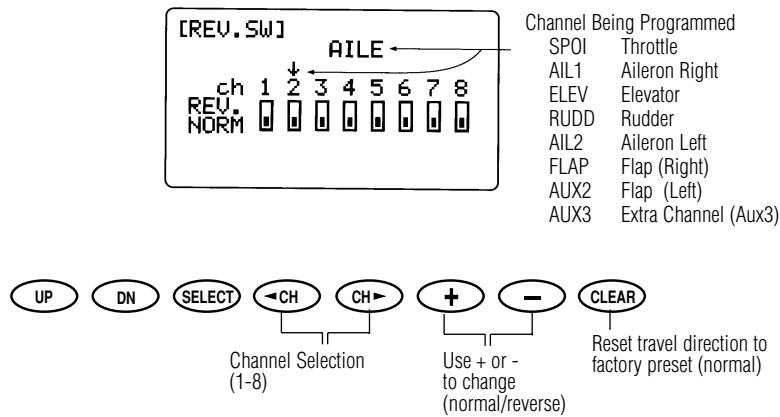

Step 5. Setting servo reversing: Turn the transmitter off and then back on again. Press the *Up* and *Down* keys simultaneously to access the Function mode. Press the *Up* key until the “REV.SW” function appears on the screen. Press the *Channel* key to select each channel and check that the servo direction is operating correctly for each channel. To change the direction of the selected channel, press the (+) or (-) key. Check and adjust all channels as necessary.

Note: When the three-position flap switch is pulled down, the flap should come down. If they go up, reverse the direction of channel 6 (FLAP) and or 7 (AUX 2).

Note: Because the GLID model programming is being used, the transmitter refers to the throttle function as SPO1 or spoilers. Any time “SPO1” is displayed, it functions as throttle.

Section 19:

Programming Guide — JR XP8103

CONTINUED

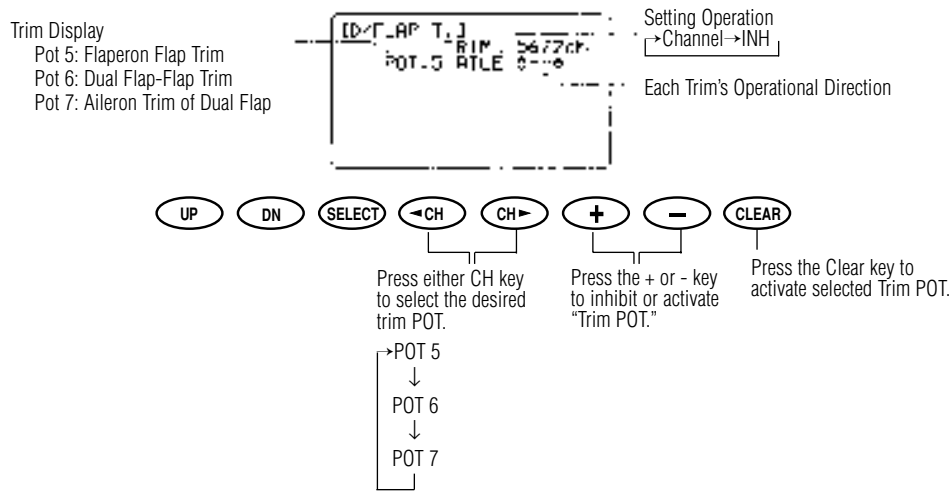

Step 6. Turning off the trim knobs: In Function mode, press the *Up* key until the “D/FLAP T”. (dual flap trim) screen appears. Pressing the *CH* key will advance through the three

available trim pots: 5, 6 and 7. Inhibit all three by pressing the (+) key when each one is selected. This will prevent any unwanted control movement should the knobs be moved.

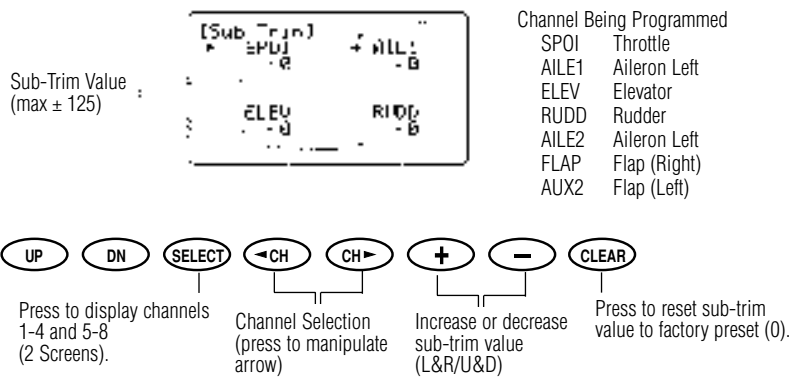

Step 7. Adjusting the sub-trims: Turn on the transmitter and receiver and center the trims. Move the flap switch in the upper position. Now reposition all the servo arms so that all the control surfaces are as close as possible to their neutral positions. In System Setup mode, press the *Up* key until the “Sub-Trim” screen appears. Now press the *Channel* key to

access the desired channel and press the (+) or (-) key to perfectly center each control surface. Press the *Select* key to access the other four channels.

Note: The throttle is referred to as “SPO1” in the glider model.

Section 19:

Programming Guide — JR XP8103

CONTINUED

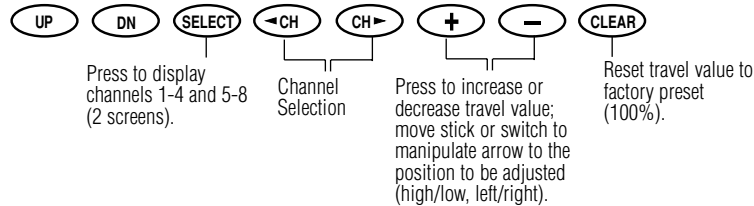
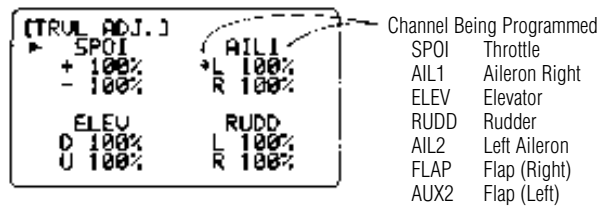

Step 8. Setting travel adjust: Press the *Up* key until the “TRVL ADJ.” screen appears. Pressing the *CH* key will allow access to each channel. Adjust the travel of each channel to the following throws using the (+) or (-) key. Move the corresponding control stick in the desired direction to adjust the travel amount in that direction. Press the *Select* key to access the other four channels.

Note: To get the most performance out of your Ultra Stick™, long servo arms (1") are recommended. This provides for large control throws for more aggressive

maneuvers. To achieve the control throws listed below, long servo arms may be necessary.

- Throttle — Full open to full closed with trim (referred to as SPO1 in GLID mode)
- Aileron — 1 1/4" up, 1 1/4" down
- Elevator — 1 1/2" up, 1 1/2" down
- Rudder — 4" right, 4" left
- Full Flaps — 1 1/2" down

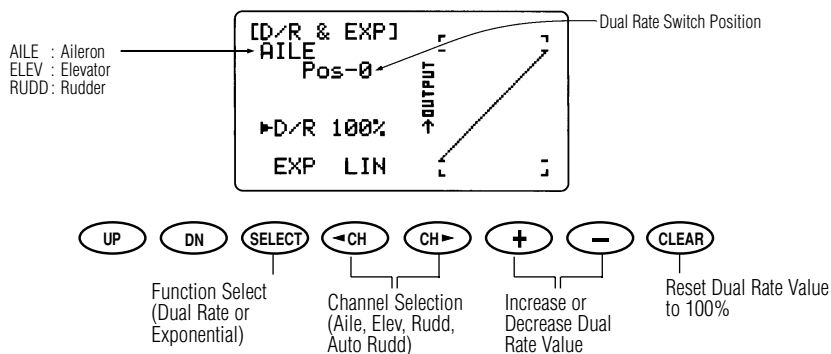

Step 9. Using exponential: Exponential is used to reduce the sensitivity of control around center while still providing full control authority when the control stick is fully deflected. Because the Ultra Stick™ 60 uses large control throws, it's a good idea to give expo a try, even if you've never used it before, to help prevent over-controlling. The exponential rate is adjusted in the same screen as the dual rate from above. In the “D/R & EXP” screen, press the *Select* key to move the cursor to the EXP at the bottom of the screen. Pressing the (+) key will adjust the expo value. Use the *Channel* key to select the aileron, elevator or

rudder channel, then use the corresponding dual rate switch to select position 0 or 1. Separate expo values can be programmed for position 0 and 1. We recommend an expo value of 30% on aileron and 25% on elevator and rudder for the first flights then, on subsequent flights, adjust the value until the desired control feel is achieved.

Always use A+ Expo Value! Using the A- expo value will actually make control response more sensitive around center and could cause a crash.

Section 19:

Programming Guide — JR XP8103

CONTINUED

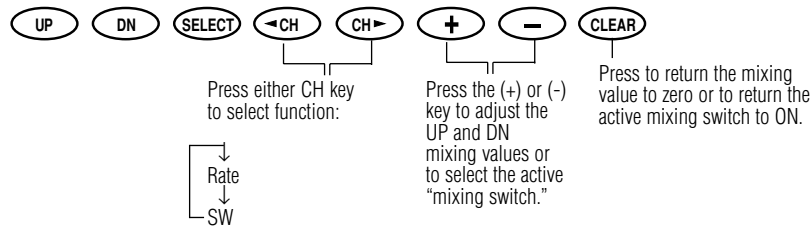
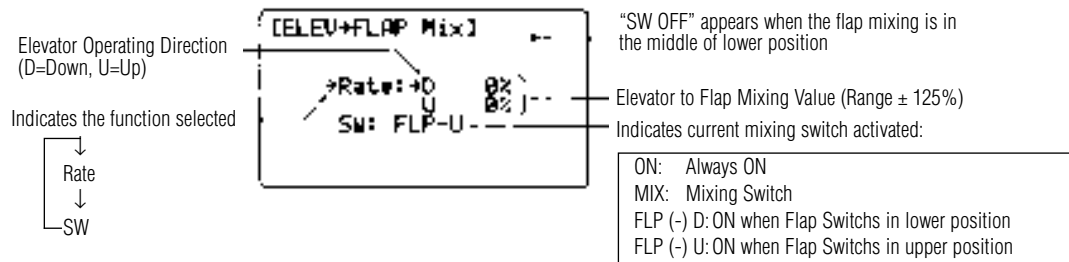

Step 10. Mixing elevator to flap: In Function mode, press the *Up* key until "ELEV-FLAP Mix" appears on your screen. This is the elevator-to-flap mix. Press the *CH* key move the cursor to SW:. This allows you to select which switch will be used to turn on/off the elevator-to-flap mixing. Pressing the (+) key will select one of the following switches: MIX = mix switch (located on the back right of the transmitter), FLP-D = flap switch down, FLP-U flap switch up, or ON = always on. We suggest selecting the mix switch mix so the elevator-to-flap mix can be turned on and off independently of the flaps. After selecting MIX, press the

CH key to return the cursor to the rate position. With the mix switch in the forward position, hold up elevator and press the (+) key until a 35% value is achieved. Up should result in down flaps. If the flap goes up, reverse the 35% value from a +35 to a -35 using the (-) key. Now hold down elevator with the control stick and press the (+) key until 35% is achieved. The flaps should go up. Reverse the value if necessary until up elevator gives down flaps and down elevator gives up flaps. Later you can experiment with more or less flap throw by changing this value. 35% is a good, safe place to start.

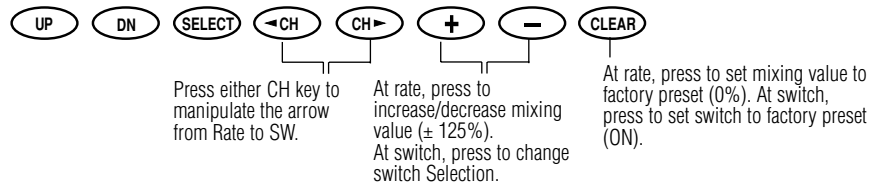
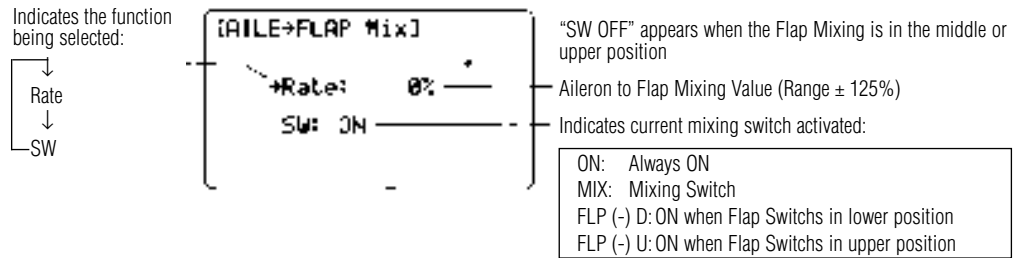

Step 11. Aileron-to-flap mixing: Press the *Up* key until the "AILE-FLAP Mix" screen appears. Press the *CH* key to move the cursor to the "SW:" position. The "SW:" allows you to select which switch is used to turn on/off the aileron-to-flap mix. Pressing the (+) key will select one of the following switches: MIX = mix switch located on the back right of the transmitter, FLP-D = flap switch down, F-U&D = flap switch up and down, and ON = always on.

We recommended putting the aileron-to-flap mix on the mix switch so the mix can be turned off independently from the flaps. After selecting "MIX," press the *CH* key to return the cursor to the "Rate" position. Now press the (+) key until +100% value is reached. Now the flaps should move in unison in the same direction with the ailerons. If they move in opposite directions, press the (-) key until a -100% value is reached.

Section 19:

Programming Guide — JR XP8103

CONTINUED

Step 12. Setting up Crow: Crow will be assigned to the flap switch and will be activated when the switch is in the down position. We've already set the flaps to the proper down position in

Step 8 travel adjust. Now we need to add the ailerons up 3/4" and the elevator down 1/4".

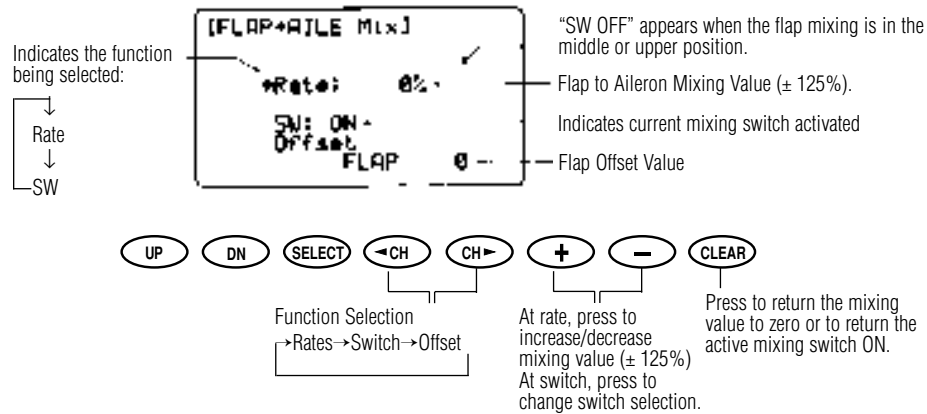

Step 13. Flap-to-aileron mixing: Press the *Up* key until the mix “FLAP-AILE” screen appears. Now press the *CH* key to move the cursor to the SW: position (flap-to-aileron switch selection). Press the (+) key until “FLP-D” (flap down) appears in the screen. Now press the *CH* key twice to return the cursor to the RATE position. Move the flap switch to the down position.

Next press the (+) key until both the ailerons go up 3/4". If the ailerons go down, press the (-) key.

Note: The flap switch must be in the down position to change the rate value.

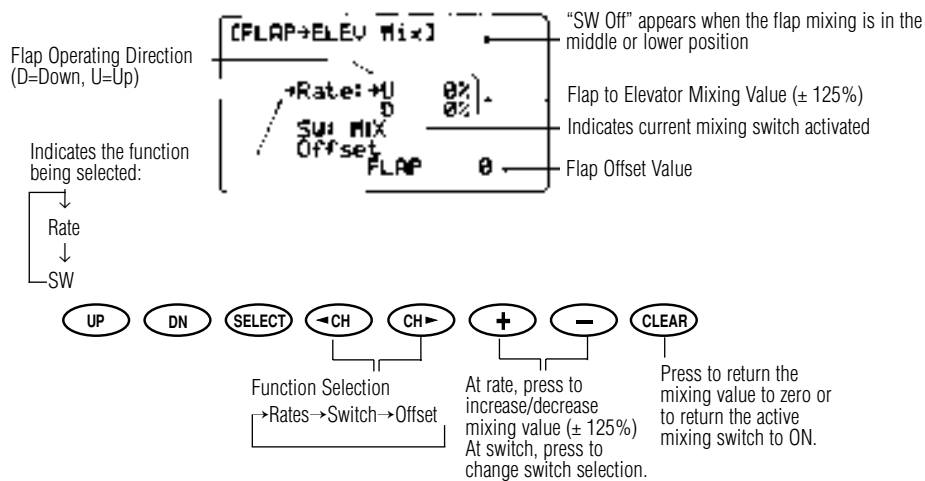

Step 14. Flap-to-elevator mixing: In Function mode, press the *Up* key until the mix “FLAP-ELEV” appears on the screen. Next press the *CH* key to move the cursor to the SW (flap-to-elevator switch selection) position. Press the (+) key until the

“FLP-D” (flap down) appears on the screen. Now press the *CH* key to return the cursor to the “Rate” position. With the flap switch in the down position, press the (+) key until the elevator comes down 1/4". If the elevator goes up, use the (-) key to reverse this.

Section 19:

Programming Guide — JR XP8103

CONTINUED

Flap Switch
UP = Normal
MID = Takeoff flaps
DOWN = Crow



Mix Switch
Turns on/off
aileron-to-flaps
and elevator-to-
flaps mixes

Section 19:

Programming Guide — JR 10X/10SXII/10SX

CONTINUED

Programming your JR10X, 10SXII or 10SX in 11 Easy Steps

JR's 10X, 10SXII and 10SX feature many of the same base-level programming features, making programming and setting up the

quad flap function on these radios identical. First, it's important to plug each servo into the correct port in the receiver.

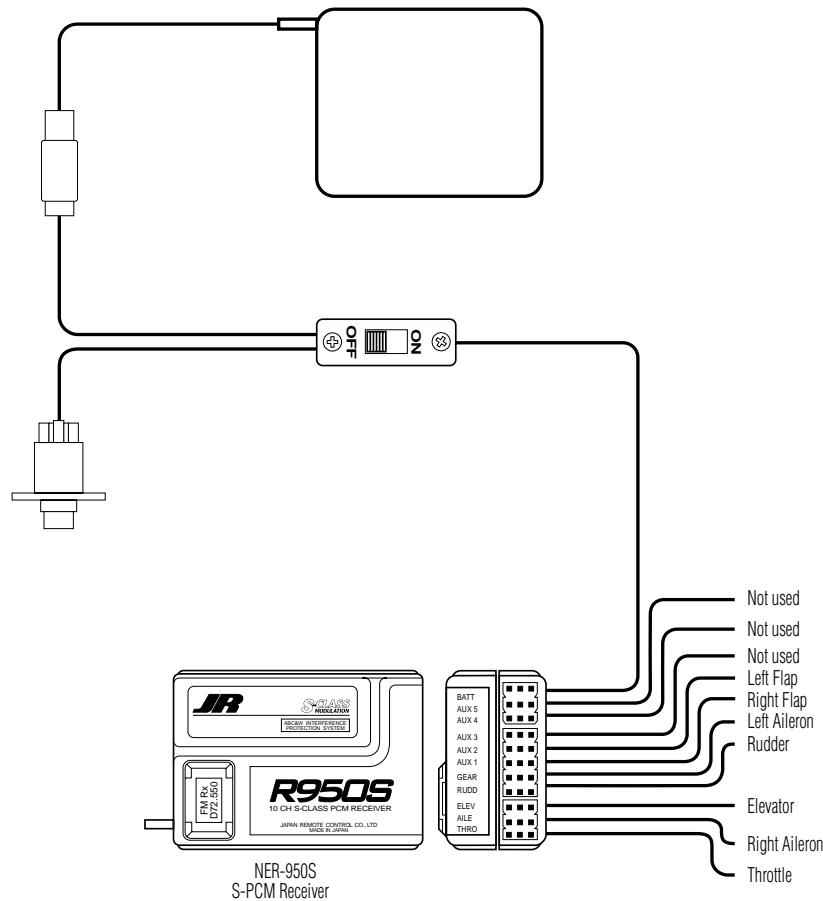

Note: When setting up a new aircraft, it's important to reset the programming to the factory defaults.

Step 1. Data Reset, Code 28: Enter Code 28 and press the *Clear* key to reset the programming to factory default settings. (The 10X will require you to verify that you want to reset with a yes or no — press YES).

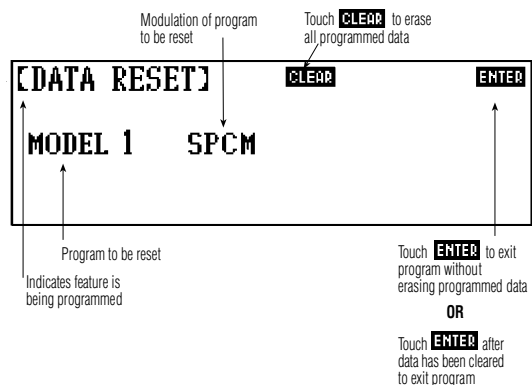

Section 19:

Programming Guide — JR 10X/10SXII/10SX

CONTINUED

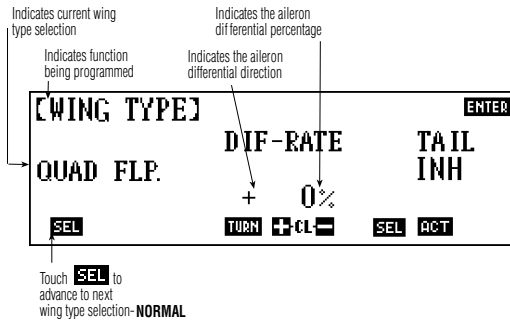

Step 2. Wing Type, Code 22: Enter Code 22 and below normal press the *SEL* key until QUAD.FLP appears. Press *Enter* to return to the Function mode screen.

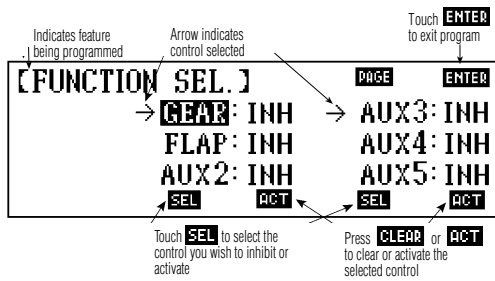

Step 3. Turn off unused channels, Code 17: Enter Code 17 and inhibit channels 5 through 10 by pressing the *SEL* key to select each channel, then press the *Clear* key to inhibit each channel.

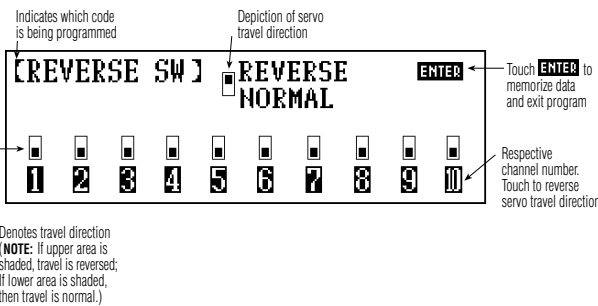

Step 4. Set the servo reversing, Code 11: Enter Code 11 and check that the direction of each servo is moving properly. Reverse any servo as necessary by pressing the numbered key that corresponds with that channel.

- 1 — Throttle
- 2 — Right Aileron
- 3 — Elevator
- 4 — Rudder
- 5 — Left Aileron
- 6 — Right Flap
- 7 — Left Flap

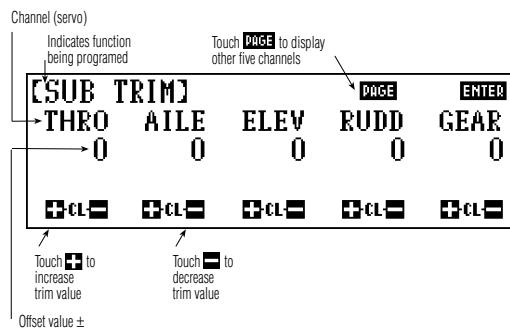

Step 5. Sub-Trims, Code 15: Turn on the transmitter and receiver and center the trims on the transmitter. Reposition any of the control arms as necessary such that the control surfaces are as close to neutral as possible. Now enter "Code 15, Sub-Trim" and fine adjust each control surface until it's perfectly neutral using the (+) or (-) keys below each corresponding channel. The *Page* key allows access to the other five channels. Pressing *Enter* will return to the Function mode.

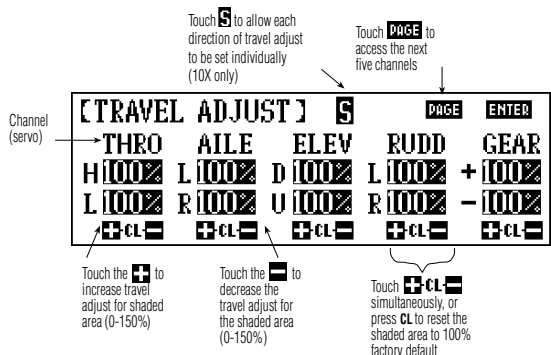

Step 6. Travel Adjust, Code 12: Enter Code 12 and adjust the control travels of each control surface to the following using the (+) or (-) key below each channel. Pressing the *Page* key will access the other five channels.

- Throttle — Full open to full closed with trim
- Aileron — 1 1/4" up, 1 1/4" down
- Elevator — 1 1/2" up, 1 1/2" down
- Rudder — 4" right, 4" left

Section 19:

Programming Guide — JR 10X/10SXII/10SX

CONTINUED



Step 7. Dual Rate and Exponential, Code 13: Enter Code 13. The *Page* key will allow you to select the aileron, elevator and rudder channels while each respective dual rate switch will allow you to select positions 0, 1, or 2 for that channel. Adjust the high rates to 100%, the middle rates to 75% and the low rates to 50% for all three channels. First flights should be made at a low 50% rate.

Exponential is used to reduce the control sensitivity around center while still providing full control authority when the control stick is fully deflected. Because the Ultra Stick™ 60 has large recommended control throws, it's a good idea to give expo a try, even if you've never used it before, to prevent over-controlling. With the PCM-10 channel radios, exponential adjusts exactly like dual rate. Select the desired channel using the *Page* key, then select the switch position using the corresponding dual rate switch, then use the (+) or (-) key to adjust the expo value. We recommend 30% as a good starting point for all channels and positions.

Later you can fine-tune the control feel to your liking after several test flights.



Step 8. Flap System, Code 66: Enter Code 66. Move the flap switch to the mid-position and below the "FLAP MID" on the right side of the screen, press the (-) key until the flap comes down 1 1/2". Next, move the flap switch to the down (land) position and, below the "FLAP LAND" on the right side of the screen, press the (-) key until the flaps come down 1 5/8". With the flap switch still in the down position, press the (+) key below "ELEV LAND" until the elevator comes down 5/8". We have just setup the takeoff flaps (switch in the center position) and the first part of the crow (switch in the lower position).

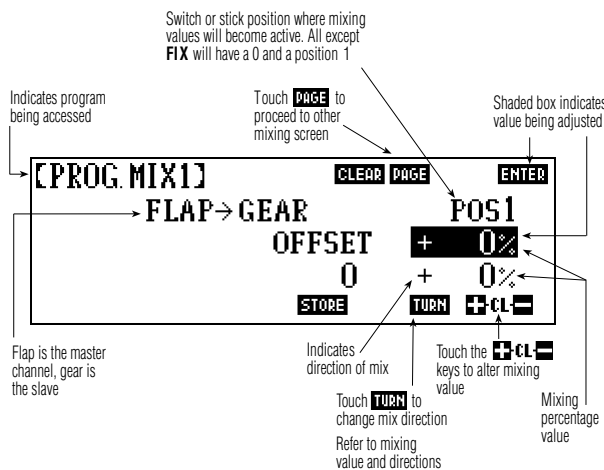

Step 9. Programmable mix for up ailerons in crow, Code 51: We will need to set up a programmable mix to allow the ailerons to move upward when crow is activated. Enter Code 51, Programmable Mix 1. Press the "6" key and then the "5" key at the bottom of the screen to select the FLAP as the master and the GEAR as the slave channels.

Next, press *Enter*. Now press *Page* to access the switch selection screen and press the key below the LD to select the *LAND* switch position to turn on the mix. Press the *Page* key twice to return to the mix screen. Move the flap switch to the lower (*LAND*) position, then press the (+) key until the ailerons go up 3/4". If the ailerons go down, press the *Turn* key.

Section 19:

Programming Guide — JR 10X/10SXII/10SX

CONTINUED

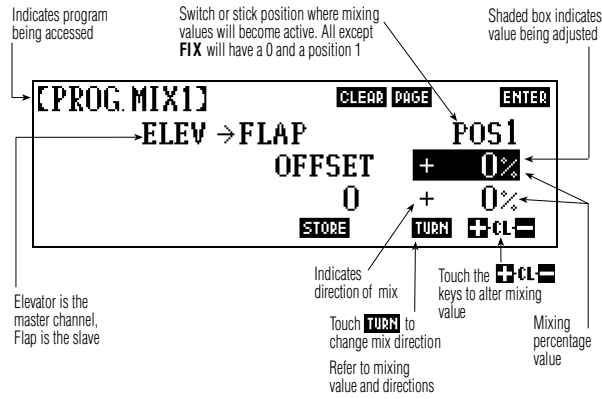

Step 10. Programmable mix for elevator-to-flap, Code 52:

Enter Code 52, Programmable Mix 2, and press the “3” key and then the “6” key to select the ELEVATOR as master and the FLAPS as slave channels. Press *Enter*, then press the *Page* key to select the switch screen. Below MX press the *SEL* key to select the mix switch to operate the mix. This will allow the elevator-to-flap mix to be turned on/off using the mix switch. Press the *Page* key twice to return to the mix screen. With the mix switch (back right side of transmitter) in the forward position, hold up elevator and press the (+) key until the flaps go down. If the flaps go in the wrong direction, press the *Turn* key. Mixing percentage value of 35% is a good place to start. Now with down elevator, press the (+) key until the flaps go up. Also use 35% as a starting point here. Later you can adjust these values to suit your flying style.

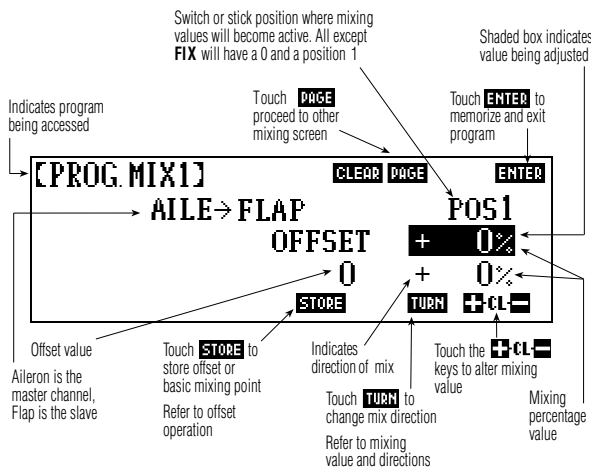

Step 11. Programmable mixing of aileron-to-flaps, Code 53:

Enter “Code 53, Programmable Mix 3.” Press the “2” key and then the “7” key to mix aileron to AUX 2, then press *Enter*. Press the *Page* key to access the switch select screen and press the *SEL* key below MX. This will turn on/off the aileron-to-flap mix with the mix switch (located at the back left of the transmitter). Press the *Page* key twice to return to the “Programmable Mix 3” screen. With the mix switch in the forward position, press the (+) key while holding the right aileron control stick until the value reads 100%. If the flap moves opposite the aileron, then press the *Turn* key. Now holding left aileron with the control stick, press the (+) key until 100% is achieved. Press the *Turn* key if necessary.

* Flap Switch

- UP = Normal
- MID = Takeoff flaps
- DOWN = Crow

- * **Mix Switch** = Turns on/off aileron-to-flap and elevator-to-flap mixes



Section 19:

Programming Guide — Futaba 8UA/S

Programming the Futaba 8UA/S in 10 Easy Steps

Before programming your radio, it's important to plug each servo into the correct servo port in the receiver.

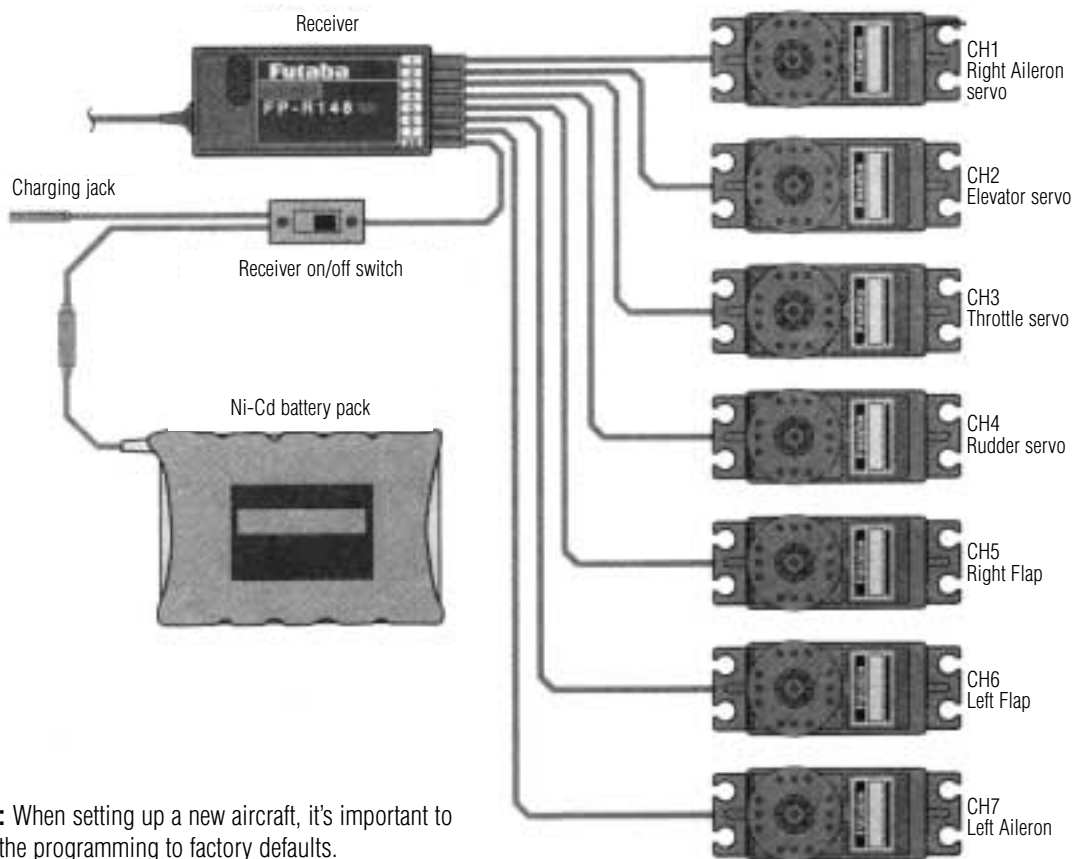

Note: When setting up a new aircraft, it's important to reset the programming to factory defaults.

Indicates NORM or REVERS throw setting

Confirmation message "OK?"

MODEL DATA RESET
Press both the (+) and (-) keys simultaneously. The confirmation message "OK?" is displayed at the top left corner of the screen. When both (+) and (-) are pressed simultaneously again, the reset process is begun. After a beep, beep tone is sounded, a continuous beep tone indicates that the reset is complete.

These keys are used to move through submenus in the PARA function.

(+) (-) Input Keys

Step 1. Data Reset: Turn on the transmitter and press the two *Basic Menu* keys simultaneously. Now press one of the *Mode* keys to access the "PARA" (parameters) screen. Press the *Cursor* key to select the "DATA RSET" screen. When the "DATA RSET" screen is displayed, pressing the (+) and (-) keys simultaneously will bring up "OK?" on the screen. To reset the memory again, press the (+) and (-) keys simultaneously.

Most of the quad flap features needed for the Ultra Stick™ 60 are already preprogrammed into the glider software (referred to as GLID 2FLP) included in the Futaba 8UA.

We strongly suggest using the GLID 2FLP model type programming in these radios when setting up quad flaps.

Section 19:

Programming Guide — Futaba 8UA/S

CONTINUED



Step 2. Selecting model type (GLID): Press the two *Basic Menu* keys simultaneously to enter the basic programming mode. Now press *Mode* key until "PARA" (parameters) appears on the screen. Press a *Cursor* key until "TYPE" appears on the

top of the screen. Next press the (+) button until "GLID 2FLP" is displayed. With "GLID 2FLP" displayed on the screen press the (+) and (-) key simultaneously twice to access the Glider 2 flaps program.

The diagram shows the 'REVERS' screen with 'AIL' and 'NORM' displayed. An arrow points to 'NORM' with the text 'Indicates NORM or REVERS throw setting'. Below the screen, it says 'Channel display' and 'NORM or REV display indicates travel setting'. A list of channels is provided: 1. Right Aileron Setting, 2. Elevator, 3. Throttle, 4. Rudder, 5. Right Flap, 6. Left Flap, 7. Left Aileron. To the right, a diagram of the control panel shows 'BASIC MENU', 'START', 'MODE', 'CURSOR', 'DATA INPUT', 'SET', 'ADVANCE MENU', and 'STOP' keys. Text above it says 'These keys are used to reverse channels 1-8 in this menu as needed.' Below the panel diagram is the label 'Data Input Keys'. A note at the bottom left says '* The blinking item is what is being set.'

1. Right Aileron Setting
Select "NORM" or "REV" with the (+)(-) keys.
2. Repeat above procedure to reverse channels 2-8 as necessary.
 - 2 = Elevator
 - 3 = Throttle
 - 4 = Rudder
 - 5 = Right Flap
 - 6 = Left Flap
 - 7 = Left Aileron

Step 3. Setting the servo reversing: In the BASIC MENU mode, press the *Mode* key until the "REVERS" screen appears. The *Cursor* key allows you to access the different channels, while pressing the (-) key reverses the selected channel (the (+) key changes that channel back to normal). Check that channels are moving in the proper direction and reverse as necessary.

Note: The throttle is referred to as ABK (air brake) in the glider mode and functions normally with the throttle stick and trimmer.

Don't worry about the flap direction at this time.

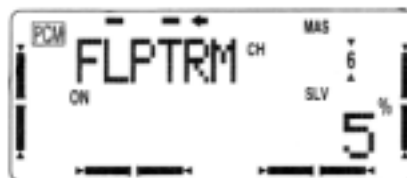

Step 4. Turning off the flap trim knob (Ch. 6): Press the *Advance Menu* keys simultaneously to enter the Advanced Menu mode. Now press the *Mode* key until "FLPTRM" appears on the

screen. Press the (+) button to turn on the flap trim function. Now press the *Cursor* so that the +30 value is blinking. Press the (-) key until a "0" appears in the screen.

Section 19:

Programming Guide — Futaba 8UA/S

CONTINUED

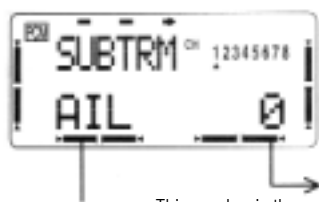

Channel Being Set (Aileron)

This number is the subtrim value (allowed to be -120 to +120) (Default value = 0).

Setting Sub-Trims

- Begin with the Aileron subtrim. Use the (+) and (-) keys to neutralize the control surface.
- Adjust the remaining controls (when used) in a similar fashion: Elevator, Throttle, and Rudder.

If you're unhappy with subtrim value, you may reset it to zero by pressing the (+) and (-) keys simultaneously.

Choose channels 1-8 with these keys.

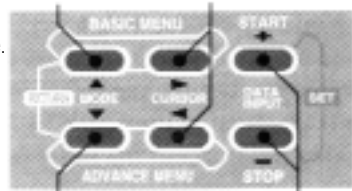

Use these keys to set subtrims.

Step 4. Adjusting sub-trims: With the transmitter and receiver turned on and the trims centered on the transmitter, reposition the servo arms as necessary so that all control surfaces are as close to neutral as possible. Now press the two *Basic Menu* keys to enter Basic mode. Press the *Mode* key to access the "SUBTRM" screen. While in the "SUBTRM" screen, pressing the *Cursor* key will scroll through channels and then

pressing the (+) or (-) key will adjust the sub-trim values. Adjust the sub-trims for each channel until each control surface is perfectly neutralized.

Note: The throttle channel is referred to as ABK (air brake) in the glider mode and functions normally with the throttle stick and trim.

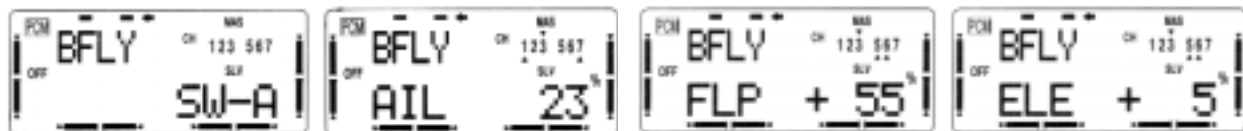

Step 5. Setting up Crow (also referred to as butterfly): Press the *Advance Menu* keys simultaneously to enter the Advanced Menu mode. Now press the *Mode* key until "BFLY" appears on the screen. Press the (+) key to activate butterfly programming. Next press the *Cursor* to access the AIL function and, with the A switch (top left corner) in the down position, adjust the value using the (+) or (-) key until the ailerons are up 3/4".

Now press the *Cursor* key until the "FLP" appears on the screen and adjust the value using the (+) or (-) key until the left aileron is up 3/4". Now press the *Cursor* key until the "ELE" appears on the screen and adjust the value until the elevator goes down 1/4". Next press the *Cursor* until "FLP" appears on the screen and adjust the value until the flaps go down 1 1/2". This presets the ailerons, flaps and elevator for Crow and it is activated on switch A.

Section 19:

Programming Guide — Futaba 8UA/S

CONTINUED

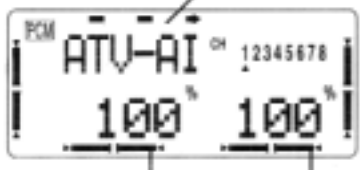

Channel Display

Left/Up Servo Throw
Range: 30-140%

Right/Down Servo Throw
Initial value = 100%

* The blinking item is what is being set.

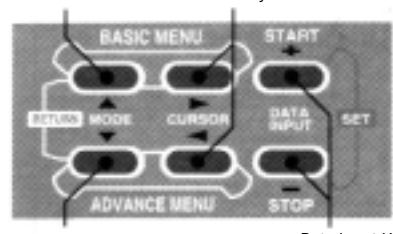

These keys are used to select the channel to be set in ATV.

Data Input Keys

You can reset to the initial values by pressing the (+) and (-) keys simultaneously.

Channel display			
No.	Channel Name	No.	Channel Name
CH1	AI = Right Aileron	CH5	Right Flap
CH2	EL = Elevator	CH6	FL = Left Flap
CH3	TH = Throttle	CH7	Channel 7 Left Aileron
CH4	RU = Rudder		

Step 6. Adjusting the travel volume: Press the two *Basic Menu* keys simultaneously to enter the Basic mode. Now press the *Mode* key until the "ATV" (adjustable travel volume) screen appears. Pressing the *Cursor* key will advance through the channels, while pressing the (+) or (-) key will increase or decrease the travel of that channel. It's necessary to adjust each direction

of each channel by moving that selected channels stick in the desired direction. Adjust each channel to the following.

- Throttle — Full open to full closes with trim
- Aileron — 1 1/4" up, 1 1/4" down
- Elevator — 1 1/2" up, 1 1/2" down
- Rudder — 4" right, 4" left

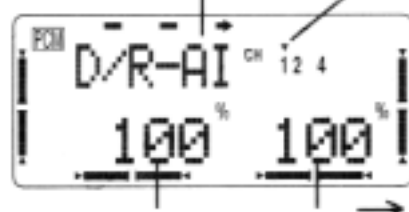

Channel display: AI = Aileron, EL = Elevator, RU = Rudder

Indicates top or bottom switch position (top shown)

The value of the stick adjusted by stick operation blinks.

Step 7. Setting dual rates: In Basic mode press the *Mode* key until the "D/RE" screen appears. This is the dual rate program. Press the *Cursor* to access the aileron, elevator or rudder channels, then press the (+) or (-) key to change the values.

Note that two dual values are available by toggling that channel's dual rate switch. On all three channels, high rate should be adjusted to 100%, while low rate should be set at 50%.

Section 19:

Programming Guide — Futaba 8UA/S

CONTINUED

Channel Display: AI = Aileron
EL = Elevator
TH = Throttle
RU = Rudder

Indicates top or bottom D/R switch position (bottom shown)

(The value of the stick adjusted by stick operation blinks)

These keys are used to move through the items in this menu.

Data Input Keys

* The blinking item is what is being set

Step 8. Setting the exponential adjustments: Exponential is used to reduce the control sensitivity around center while still providing full control authority when the control stick is full deflected. Because the Ultra Stick™ has large recommended control throws, it's a good idea to give expo a try, even if you've never used it before, to prevent over-controlling. In Basic mode, press the *Mode* key until the "EXP" function appears on the

screen. Pressing the *Cursor* key will allow access of the aileron, elevator, rudder and AB (throttle) channels. Toggling the respective dual rate switch will allow one of two expo values to be stored. It's recommended that a -30% expo be programmed for aileron, elevator and rudder as a good starting point. Later after several test flights you can fine-tune the control feel to your liking.

1. Turn the ELE-FL function ON or OFF by pressing the (+) key ("ON" or "OFF" displayed). Turn off (INH) the function with the (-) key.

Flap travel due to DOWN Elevator stick Flap travel due to UP Elevator stick

Flap UP and DOWN travel input. Push the elevator stick in the direction you want to adjust and set the desired travel with the (+)/(-) keys. Press the (+) and (-) keys simultaneously to reset to 50%.

Allowed flap travel Range: -100 to +100%
Initially set to 50%

These keys are used to move through the two submenus in the ELE-FL function.

Data Input Keys

Step 9. Elevator-to-flap mixing: Press the Advance Menu keys simultaneously to access the Advanced Menu mode. Next press the *Mode* key until "ELE-FL" (elevator-to-flaps) appears on the screen. Press the (+) key to activate elevator-to-flaps. With flap switch C in the up position (ELE-FLP), press the *Cursor* key until the value is blinking. Then use the (+) or (-) key while holding the elevator stick in the desired up or down position to change the values so that up elevator gives down flaps and

down flaps gives up elevator. A value of 35% in both directions is a good place to start.

Note: If flaps travel in the wrong direction when elevator is applied, reverse the value using the (+) or (-) key. E.G., +35% to -35%. The ELE-FLP switch is used to turn on/off this function.

Section 19:

Programming Guide — Futaba 8UA/S

CONTINUED

1. Turn the AIL-FL function ON or OFF by pressing the (+) key ("ON" or "OFF" displayed depending on switch G's position). Turn off (INH) the function with the (-) key.



Aileron Mix from Flaps Flap Neutral Position

Range: -100 to +100%
(initial value: 0%)

2. Flap travel setting
Push the aileron stick in the direction you want to adjust and adjust the flap amount with the (+) and (-) keys. Repeat for other aileron stick position.

- If you're unhappy with what you've set, you may return to the default value by pressing the (=) and (-) keys simultaneously.

These keys are used to move through the three submenus in the AIL-FL function.

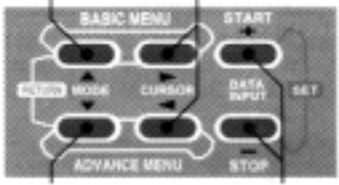

Data Input Keys

3. Activation Switch Direction/Disabling
Select the desired direction for Switch G to turn the function on and off with the (+)/(-) keys.

- "UP" = Upper position turns on AIL-FL mixing
- "DOWN" = Lower position turns on AIL-FL mixing
- "NULL" = AIL-FL mixing is always on, switch disabled.

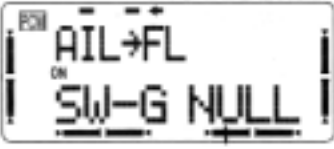

Switch direction display
(NULL, UP, DOWN)

Step 10. Aileron-to-flap mixing: In Advanced Menu Mode, press the *Mode* key until the "AIL-FL" screen appears. Next press the + button to activate the aileron-to-flap mixing. Press the *Cursor* so that the 0 value is blinking. Now press the (+) or (-) keys while holding right then left aileron until the flap moves

in unison with the ailerons. A starting value of 50% is a good place to start. Now press the *Cursor* key until "SW-E" appears and press the (+) key until "Down" appears on the screen. This assigns the aileron-to-flap mix to the E switch, and it's on when the switch is pulled forward.



Range Test Your Radio

1. Before each flying session, be sure to range check your radio. This is accomplished by turning on your transmitter with the antenna collapsed. Turn on the radio in your airplane. With your airplane on the ground, you should be able to walk 30 paces away from your airplane and still have complete control of all functions. If not, don't attempt to fly! Have your radio equipment checked out by the manufacturer.

2. Double-check that all controls (aileron, elevator, throttle, rudder, etc.) move in the correct direction.

3. Be sure that your batteries are fully charged, per the instructions included with your radio.

Adjusting the Engine

1. Completely read the instructions included with your engine and follow the recommended break-in procedure. At the field adjust the engine to a slightly rich setting at full throttle and adjust the idle and low speed needle so that a consistent idle is achieved. Before you fly be sure that your engine reliably idles, transitions and runs at all throttle settings. Only when this is achieved should any plane be considered ready for flight.

Notes

AMA SAFETY CODE

Official AMA National Model Aircraft Safety Code Effective January 1, 1999
Model flying MUST be in accordance with this Code in order for AMA Liability Protection to apply.

General

1. I will not fly my model aircraft in sanctioned events, air shows, or model flying demonstrations until it has been proven to be airworthy by having been previously, successfully flight tested.
2. I will not fly my model higher than approximately 400 feet within 3 miles of an airport without notifying the airport operator. I will give right-of-way and avoid flying in the proximity of full-scale aircraft. Where necessary, an observer shall be utilized to supervise flying to avoid having models fly in the proximity of full-scale aircraft.
3. Where established, I will abide by the safety rules for the flying site I use, and I will not willfully and deliberately fly my models in a care-less, reckless and/or dangerous manner.
4. At all flying sites a straight or curved line(s) must be established in front of which all flying takes place with the other side for spectators. Only personnel involved with flying the aircraft are allowed in front of the flight line. Flying over the spectator side of the line is prohibited, unless beyond the control of the pilot(s). In any case, the maximum permissible takeoff weight of the models is 55 pounds.
5. At air shows or model flying demonstrations a single straight line must be established, one side of which is for flying, with the other side for spectators. Only those persons accredited by the contest director or other appropriate official as necessary for flight operations or as having duties or functions relating to the conduct of the show or demonstration are to be permitted on the flying side of the line. The only exceptions which may be permitted to the single straight line requirements, under special circumstances involving consideration of side conditions and model size, weight, speed, and power, must be jointly approved by the AMA President and the Executive Director.
6. Under all circumstances, if my model weighs over 20 pounds, I will fly it in accordance with paragraph 5 of this section of the AMA Safety Code.
7. I will not fly my model unless it is identified with my name and address or AMA number, on or in the model. Note: This does not apply to models flown indoors.
8. I will not operate models with metal-bladed propellers or with gaseous boosts, in which gases other than air enter their internal combustion engine(s); nor will I operate models with extremely hazardous fuels, such as those containing tetranitromethane or hydrazine.

9. I will not operate models with pyrotechnics (any device that explodes, burns, or propels a projectile of any kind) including, but not limited to, rockets, explosive bombs dropped from models, smoke bombs, all explosive gases (such as hydrogen-filled balloons), ground mounted devices launching a projectile. The only exceptions are rockets flown in accordance with the National Model Rocketry Safety Code or those permanently attached (as per JATO use); also those items authorized for Air Show Team use as defined by AST Advisory Committee (document available from AMA HQ). Models using rocket motors are limited to a maximum weight of 3.3 pounds and a G series motor.

10. I will not operate any turbo jet engine (axial or centrifugal flow) unless I have obtained a special waiver for such specific operations from the AMA President and Executive Director and I will abide by any restriction(s) imposed for such operation by them. (Note: This does not apply to ducted fan models using piston engines or electric motors.)

11. I will not consume alcoholic beverages prior to, nor during, participation in any model operations.

Radio Control

1. I will have completed a successful radio equipment ground range check before the first flight of a new or repaired model.
2. I will not fly my model aircraft in the presence of spectators until I become a qualified flier, unless assisted by an experienced helper.
3. I will perform my initial turn after takeoff away from the pit or spectator areas, and I will not thereafter fly over pit or spectator areas, unless beyond my control.
4. I will operate my model using only radio control frequencies currently allowed by the Federal Communications Commission. (Only properly licensed Amateurs are authorized to operate equipment on Amateur Band frequencies.)
5. I will not knowingly operate an R/C system within 3 miles of a pre-existing model club-flying site without a frequency sharing agreement with that club.
6. I will not fly my model aircraft in any racing competition, which allows models over 20 pounds unless that competition event is AMA sanctioned. (For the purpose of this paragraph, competition is defined as any situation where a winner is determined.)
7. Every organizational racing event requires that all officials, callers, and contestants must properly wear helmets, which are OSHA, DOT, ANSL, SNELL, NOCSAE or comparable standard while on the racecourse. In addition, all officials occupying safety cages must wear protective eyewear.

