



Fly First Class™

Piper J-3 Cub

ASSEMBLY MANUAL



Specifications

Wingspan..... 106 in (2692.5mm)
 Wing Area 1630 sq in (10.52 sq dm)
 Length..... 68 in (1727mm)
 Weight..... 14.5–16.5 lb (6.6 kg–7.5 kg)

Engine..... 1.00–1.80 Four-Stroke
 1.00–1.60 Two-Stroke
 20–26cc Gasoline
 Motor E-flite Power 110

Table of Contents

Using the Manual	3
Required Tools and Adhesives	3
UltraCote Covering Colors	3
Before Starting Assembly	3
Radio and Power Systems Requirements	4
Instructions for Disposal of WEEE by Users in the European Union	4
Warranty Period	5
Limited Warranty	5
Damage Limits	5
Safety Precautions	5
Questions, Assistance, and Repairs	6
Inspection or Repairs	6
Warranty Inspection and Repairs	6
Non-Warranty Repairs	6
Safety, Precautions, and Warnings	7
Contents of Kit	7
Hinging the Control Surfaces	8
Landing Gear Installation	10
Stabilizer Installation	13
Aileron Servo Installation	16
Radio Installation	20
Engine Installation (Glow)	26
Engine Installation (Gas)	30
Interior Detail Installation	33
Wing Installation	36
Control Throws	39
Recommended Center of Gravity (CG)	39
Pre-Flight	40
Adjusting the Engine	40
Range Test Your Radio	40
Building and Flying Notes	41
2007 Official AMA National Model Aircraft Safety Code	42

Using the Manual

This manual is divided into sections to help make assembly easier to understand, and to provide breaks between each major section. In addition, check boxes have been placed next to each step to keep track of each step completed. Steps with a single box (☐) are performed once, while steps with two boxes (☐ ☐) indicate that the step will require repeating, such as for a right or left wing panel, two servos, etc. Remember to take your time and follow the directions.

Required Tools and Adhesives

Tools

- Rotary tool (Dremel)
- Pliers
- T-pins
- Solder
- Solder gun
- Tape
- Phillips screwdriver
- Felt-tipped pen
- Hex wrench: 5/64-inch, 3/32-inch, 7/64-inch, 1/8-inch
- Drill bit: 1/16-inch (1.5mm), 5/64-inch (2mm), 5/32-inch (4mm), 3/16-inch (4.5mm)
- Hobby scissors
- Clamp
- Crimping tool/vice grips
- String
- 1/4-inch (6mm) foam
- Hobby knife
- Drill
- Nut driver: 1/4-inch

Adhesives

- Thin CA (PAAPT08)
- 30-Minute Epoxy (HAN8002)
- CA Remover/Debonder (PAAPT16)
- Medium CA (PAAPT02)
- Formula 560 Canopy Glue (PAAPT56)
- Pacer Z-42 Threadlock (PAAPT42)

UltraCote Covering Colors

- Cub Yellow HANU884

Before Starting Assembly

Before beginning the assembly of the Piper J-3 Cub, remove each part from its bag for inspection. Closely inspect the fuselage, wing panels, rudder, and stabilizer for damage. If you find any damaged or missing parts, contact the place of purchase.

If you find any wrinkles in the covering, use a heat gun or sealing iron to remove them. Use caution while working around areas where the colors overlap to prevent separating the colors.



HAN101 – Sealing Iron

**HAN141 – Sealing Iron
Sock**



HAN100 – Heat Gun

HAN150 – Covering Glove

Radio and Power Systems Requirements

- 4-channel radio system (minimum) w/receiver
- 12-Inch Servo Lead Extension (JRPA098)
- 18-inch Servo Lead Extension (JRPA099) (4)
- Y-harness (Ailerons) (JSP98020) (Required when using 4-channel radio)
- DS821 Digital Sport Hi-Torque Servo (JRPS821) (JSP20071) (6) or equivalent
- Large Servo Arms (JRPA212) (3 pkgs)
- JR Charge Jack Switch (JRPA004)
- Choke Rings (JRPA029) (2)

The elevator installation will require:

Two servos and mixing through the radio

Or

Two servos and a JR® MatchBox™ (JPA0900) or a 6" standard reversing Y-harness (EXRA320)

Or

A standard rotation servo and a reverse rotation servo and a standard Y-harness

Recommended JR®, JR SPORT™ and Spektrum™ Systems

- XP9303
- DX7
- XS600
- XP7202
- XP6102



Spektrum DX7



JR XP9303



JR XP6102

Recommended Setup—Gas/Glow

- Zenoah® 20cc Electronic Ignition(ZENE20EI), OR
- 38mm stand-offs (Zenoah only) (EVO3307)
- RF choke ring (gas only) (JRPA029)
- Saito™ 180 AAC with Muffler (SAIE180 or SAIE180GK)
- Muffler Right Angle Adapter (Saito only) (SAI120S140)
- 16x6 Propeller
- Propeller nut

Recommended Setup—Electric

- E-flite® Power 110 BL Outrunner Motor (EFLM4110A)
- Castle Creations 85A ESC (CSEPHX85HV)
- 2 Thunder Power 8–9S Li-Po Battery Packs
- Propeller ((APC17010E) or (APC18080E)
- Propeller nut

FS One

With FS One™ you get more than photorealistic fields, gorgeous skies and realistic-looking aircraft. You get incredibly advanced aerodynamic modeling that simulates every possible aspect of real-world flight.



E-Flite Power 110
EFLM4110A



Saito 1.80 Golden Knight AAC
SAIE180GK



Zenoah 20cc
ZENE20EI



HANS2000

Warranty Period

Exclusive Warranty- Horizon Hobby, Inc., (Horizon) warrants that the Products purchased (the "Product") will be free from defects in materials and workmanship at the date of purchase by the Purchaser.

Limited Warranty

(a) This warranty is limited to the original Purchaser ("Purchaser") and is not transferable. REPAIR OR REPLACEMENT AS PROVIDED UNDER THIS WARRANTY IS THE EXCLUSIVE REMEDY OF THE PURCHASER. This warranty covers only those Products purchased from an authorized Horizon dealer. Third party transactions are not covered by this warranty. Proof of purchase is required for warranty claims. Further, Horizon reserves the right to change or modify this warranty without notice and disclaims all other warranties, express or implied.

(b) Limitations- HORIZON MAKES NO WARRANTY OR REPRESENTATION, EXPRESS OR IMPLIED, ABOUT NON-INFRINGEMENT, MERCHANTABILITY OR FITNESS FOR A PARTICULAR PURPOSE OF THE PRODUCT. THE PURCHASER ACKNOWLEDGES THAT THEY ALONE HAVE DETERMINED THAT THE PRODUCT WILL SUITABLY MEET THE REQUIREMENTS OF THE PURCHASER'S INTENDED USE.

(c) Purchaser Remedy- Horizon's sole obligation hereunder shall be that Horizon will, at its option, (i) repair or (ii) replace, any Product determined by Horizon to be defective. In the event of a defect, these are the Purchaser's exclusive remedies. Horizon reserves the right to inspect any and all equipment involved in a warranty claim. Repair or replacement decisions are at the sole discretion of Horizon. This warranty does not cover cosmetic damage or damage due to acts of God, accident, misuse, abuse, negligence, commercial use, or modification of or to any part of the Product. This warranty does not cover damage due to improper installation, operation, maintenance, or attempted repair by anyone other than Horizon. Return of any goods by Purchaser must be approved in writing by Horizon before shipment.

Damage Limits

HORIZON SHALL NOT BE LIABLE FOR SPECIAL, INDIRECT OR CONSEQUENTIAL DAMAGES, LOSS OF PROFITS OR PRODUCTION OR COMMERCIAL LOSS IN ANY WAY CONNECTED WITH THE PRODUCT, WHETHER SUCH CLAIM IS BASED IN CONTRACT, WARRANTY, NEGLIGENCE, OR STRICT LIABILITY. Further, in no event shall the liability of Horizon exceed the individual price of the Product on which liability is asserted. As Horizon has no control over use, setup, final assembly, modification or misuse, no liability shall be assumed nor accepted for any resulting damage or injury. By the act of use, setup or assembly, the user accepts all resulting liability.

If you as the Purchaser or user are not prepared to accept the liability associated with the use of this Product, you are advised to return this Product immediately in new and unused condition to the place of purchase.

Law: These Terms are governed by Illinois law (without regard to conflict of law principals).

Safety Precautions

This is a sophisticated hobby Product and not a toy. It must be operated with caution and common sense and requires some basic mechanical ability. Failure to operate this Product in a safe and responsible manner could result in injury or damage to the Product or other property. This Product is not intended for use by children without direct adult supervision. The Product manual contains instructions for safety, operation and maintenance. It is essential to read and follow all the instructions and warnings in the manual, prior to assembly, setup or use, in order to operate correctly and avoid damage or injury.

Questions, Assistance, and Repairs

Your local hobby store and/or place of purchase cannot provide warranty support or repair. Once assembly, setup or use of the Product has been started, you must contact Horizon directly. This will enable Horizon to better answer your questions and service you in the event that you may need any assistance. For questions or assistance, please direct your email to productsupport@horizonhobby.com, or call 877.504.0233 toll free to speak to a service technician.

Inspection or Repairs

If this Product needs to be inspected or repaired, please call for a Return Merchandise Authorization (RMA). Pack the Product securely using a shipping carton. Please note that original boxes may be included, but are not designed to withstand the rigors of shipping without additional protection. Ship via a carrier that provides tracking and insurance for lost or damaged parcels, as **Horizon is not responsible for merchandise until it arrives and is accepted at our facility**. A Service Repair Request is available at www.horizonhobby.com on the "Support" tab. If you do not have internet access, please include a letter with your complete name, street address, email address and phone number where you can be reached during business days, your RMA number, a list of the included items, method of payment for any non-warranty expenses and a brief summary of the problem. Your original sales receipt must also be included for warranty consideration. Be sure your name, address, and RMA number are clearly written on the outside of the shipping carton.

Warranty Inspection and Repairs

To receive warranty service, you must include your original sales receipt verifying the proof-of-purchase date. Provided warranty conditions have been met, your Product will be repaired or replaced free of charge. Repair or replacement decisions are at the sole discretion of Horizon Hobby.

Non-Warranty Repairs

Should your repair not be covered by warranty the repair will be completed and payment will be required without notification or estimate of the expense unless the expense exceeds 50% of the retail purchase cost. By submitting the item for repair you are agreeing to payment of the repair without notification. Repair estimates are available upon request. You must include this request with your repair. Non-warranty repair estimates will be billed a minimum of ½ hour of labor. In addition you will be billed for return freight. Please advise us of your preferred method of payment. Horizon accepts money orders and cashiers checks, as well as Visa, MasterCard, American Express, and Discover cards. If you choose to pay by credit card, please include your credit card number and expiration date. Any repair left unpaid or unclaimed after 90 days will be considered abandoned and will be disposed of accordingly. **Please note: non-warranty repair is only available on electronics and model engines.**

Electronics and engines requiring inspection or repair should be shipped to the following address:

Horizon Service Center
4105 Fieldstone Road
Champaign, Illinois 61822

All other Products requiring warranty inspection or repair should be shipped to the following address:

Horizon Product Support
4105 Fieldstone Road
Champaign, Illinois 61822

Please call 877-504-0233 with any questions or concerns regarding this product or warranty.

Safety, Precautions, and Warnings

This model is controlled by a radio signal that is subject to interference from many sources outside your control. This interference can cause momentary loss of control so it is advisable to always keep a safe distance in all directions around your model, as this margin will help to avoid collisions or injury.

- Always operate your model in an open area away from cars, traffic, or people.
- Avoid operating your model in the street where injury or damage can occur.
- Never operate the model into the street or populated areas for any reason.
- Never operate your model with low transmitter batteries.
- Carefully follow the directions and warnings for this and any optional support equipment (chargers, rechargeable battery packs, etc.) that you use.
- Keep all chemicals, small parts and anything electrical out of the reach of children.
- Moisture causes damage to electronics. Avoid water exposure to all equipment not specifically designed and protected for this purpose.

Contents of Kit

Replacement Parts

A.	HAN4551	25% J-3 Cub Fuselage
B.	HAN4552	25% J-3 Cub Left Wing w/Aileron
C.	HAN4553	25% J-3 Cub Right Wing w/Aileron
D.	HAN4554	25% J-3 Cub Stab and Elevator Set
E.	HAN4555	25% J-3 Cub Rudder
F.	HAN4556	25% J-3 Cub Cowl
G.	HAN4559	25% J-3 Cub Window Set
H.	HAN4562	25% J-3 Cub Wing Strut Set

Items Not Shown

HAN1987	25% J-3 Cub 17oz Tank
HAN2033	Hangar 9 Engine Mount
HAN4557	25% J-3 Cub Anodized Wing Tube
HAN4558	25% J-3 Cub Stab Tube
HAN4560	25% J-3 Cub Landing Gear w/o Wheels
HAN4561	25% J-3 Cub 4 1/4-inch Wheels (pr)
HAN4563	25% J-3 Cub Wing Strut Pins w/Keepers
HAN4564	25% J-3 Cub Tailwheel Assembly
HAN4565	25% J-3 Cub Decals
HAN4566	25% J-3 Cub Pilot Figure
HAN4567	25% J-3 Cub Dash Panel
HAN4568	25% J-3 Cub Pushrod Set
HAN4569	Side and Top Window Set
HAN4570	25% J-3 Cub Tail Wire Set
HAN4571	25% J-3 Cub Interior Seat Set

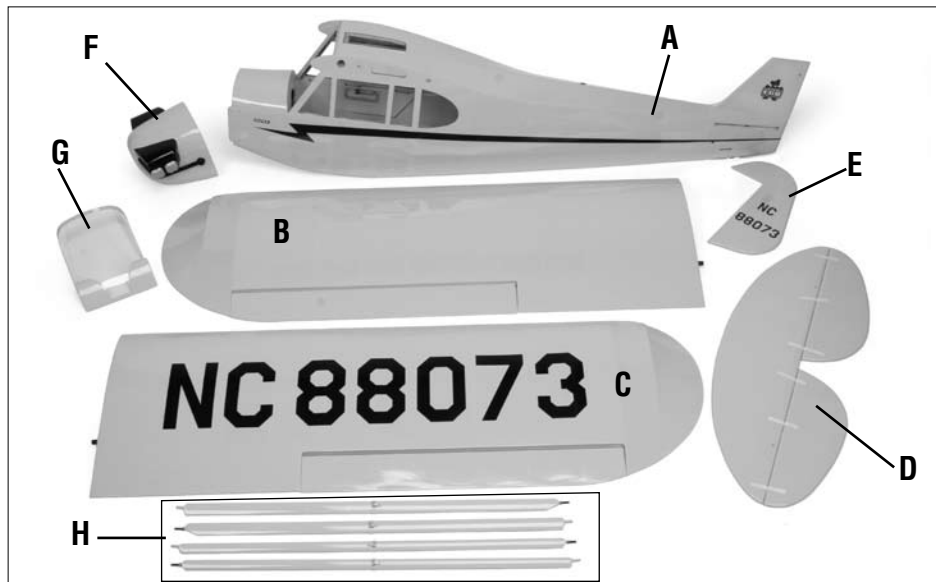

Hinging the Control Surfaces

Required Parts

- Stabilizer (2)
- Wing (left and right)
- Aileron (left and right)
- CA hinge (19)
- Elevator (2)
- Rudder
- Fuselage

Required Tools and Adhesives

- Rotary tool
- Thin CA
- Drill bit: 1/16-inch (1.5mm)
- T-pins

□ □ □ Step 1

Use a rotary tool and 1/16-inch (1.5mm) drill bit to drill a hole in the center of each of the three hinge slots in both of the stabilizers.



Note: While your rotary tool is out, drill the holes in the elevators, ailerons, wing, rudder and fin as well.

□ □ □ Step 2

Place a T-pin in the center of three CA hinges.

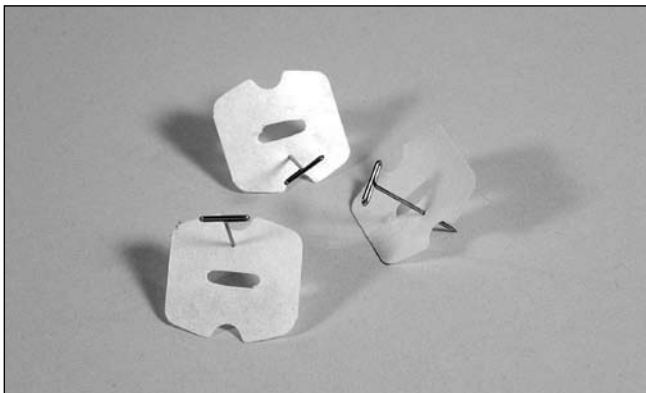

□ □ □ Step 3

Position the hinge in the stabilizer. The slot in the hinge will align with the hole drilled in the stabilizer.

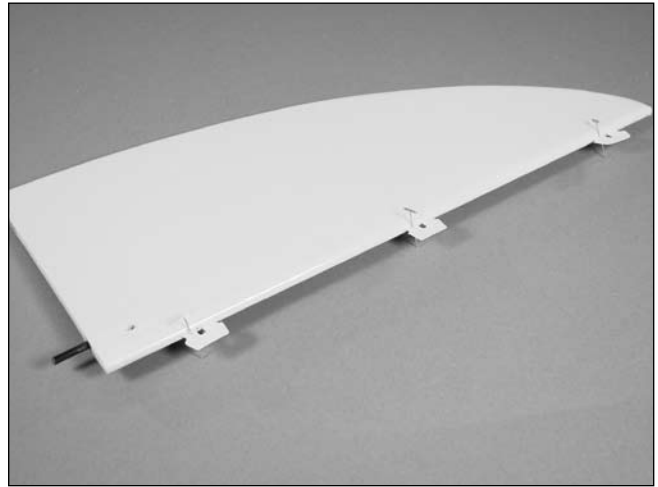

□ □ □ Step 4

Slide the hinges in the elevator. Position the stabilizer and elevator so there is as little gap between the two as possible without restricting movement. Align the tips of the stabilizer and elevator.

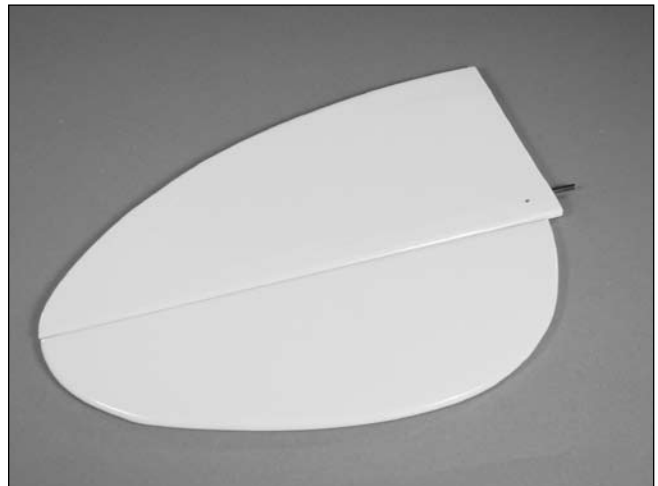

Hinging the Control Surfaces

□ □ □ Step 5

Apply thin CA to the top and bottom of each of the three hinges. Make sure to saturate each hinge so there is enough CA to wick into the hinge and bond with the surrounding wood.

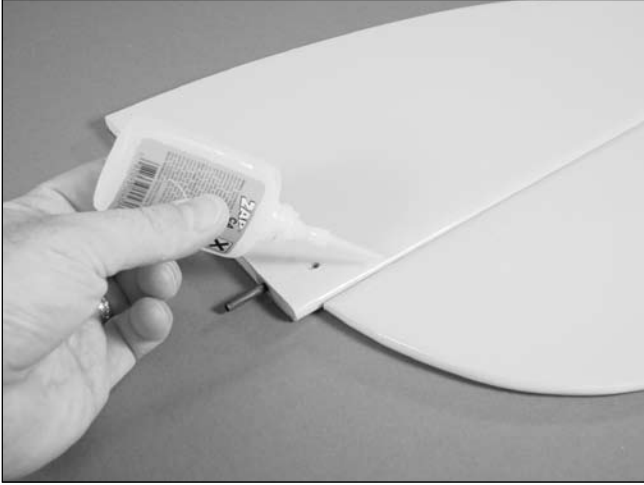

Note: Do not use CA accelerator on the hinges. The CA must be allowed to wick fully into the hinge to provide the best bond between the hinge and the surrounding wood.

□ □ □ Step 6

Allow the CA plenty of time to cure. Once cured, pull on the elevator and stabilizer to make sure the hinges are fully glued into position.



□ □ □ Step 7

Flex the elevator up and down a number of times to break in the hinges.

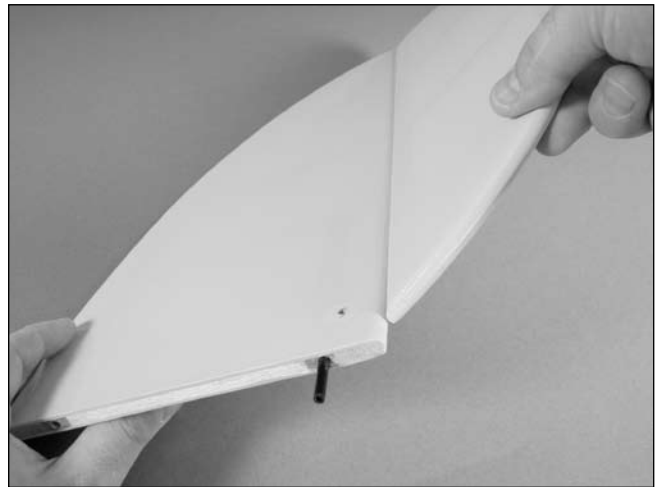

Hinging the Control Surfaces

□ □ Step 8

Repeat Steps 1 through 8, and using five hinges per aileron, hinge the ailerons to the wing panels.



□ Step 9

Repeat Steps 1 through 8, and using three hinges, hinge the rudder to the fin/fuselage.



Landing Gear Installation

Required Parts

- Fuselage
- Wheel axle (2)
- Wheel assembly (2)
- Wheel axle (2)
- Cross brace
- Wing strut tab (2)
- 4-40 locknut (6)
- 4-40 setscrew (2)
- Assembled shock strut (2)
- Wheel collar w/setscrew (2)
- Main gear strut (right and left)
- 4-40 x 1/2-inch socket head screw (2)
- 4-40 x 5/8-inch socket head screw (4)
- 8-32 x 3/4-inch socket head screw (8)
- #2 x 5/8-inch sheet metal screw (8)

Required Tools and Adhesives

- Threadlock
- Hex wrench (included in kit for wheel collars)
- Phillips screwdriver (#1)
- Hex wrench: 3/32-inch, 1/8-inch
- Nut driver: 1/4-inch

Note: Be sure the 6-32 bolts that secure the landing gear legs to the landing brackets are snug to minimize vibration, but allow for movement

□ Step 1

Locate the left and right main gear struts and the wing strut tab. Attach the front of the landing gear using two 8-32 x 3/4-inch socket head screws. The rear is also secured to the fuselage using four 8-32 x 3/4-inch socket head screws, but the wing strut tabs are positioned between the landing gear and fuselage.



Note: Use threadlock on the 8-32 x 3/4-inch socket head screws to prevent them from vibrating loose in flight.

Landing Gear Installation

Note: In Step 2, leave the screws loose in the gear until all the struts and cross brace are in position.

□ □ Step 2

Use two 4-40 x 5/8-inch socket head screws and two 4-40 locknuts to attach the shock struts to the main landing gear struts. The cross brace also uses two 4-40 x 5/8-inch socket head screws and 4-40 locknuts to attach to the gear near the fuselage. Last, use two 4-40 x 1/2-inch socket head screws and two 4-40 locknuts to attach the shock struts to the cross brace.

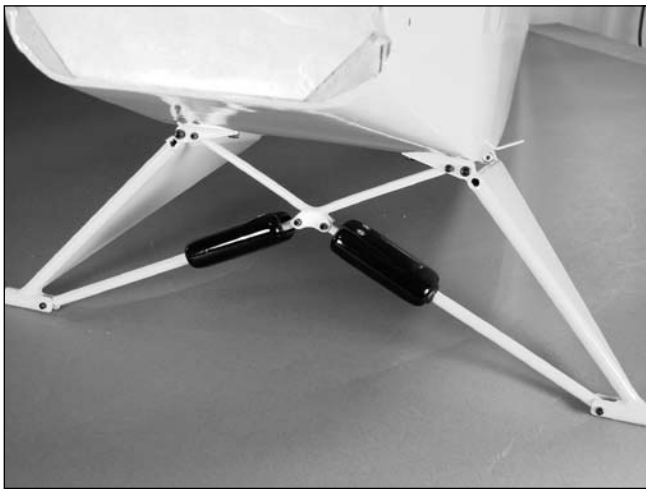

□ □ Step 3

Locate the main wheel and remove the front and rear hubs from the wheel.



□ □ Step 4

Secure the wheel collar to the axle by tightening the setscrew onto the flat of the axle with the included hex wrench.

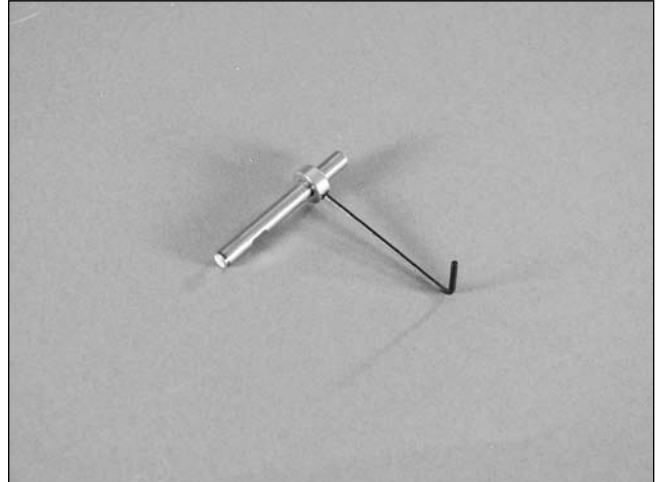

Note: Use threadlock on the setscrew to prevent it from vibrating loose in flight.

□ □ Step 5

Slide the rear hub into the wheel. The rear hub is identified as the one without the holes going through the hub for the screws. Slide the longer portion of the axle into the hub, then slide the front hub into the wheel.

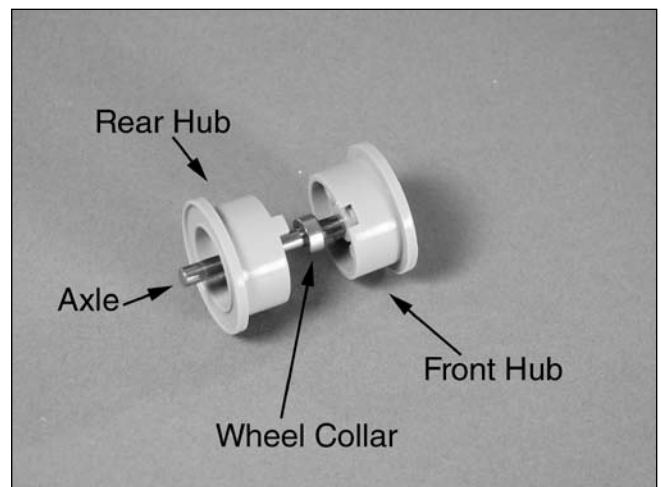

Note: The photo **does not** show the wheel to illustrate how the wheel collar is placed between the two wheel hubs to hide the wheel collar.

Landing Gear Installation

Step 6

The front and rear hubs will key together when installed properly. Once installed, use four #2 x 5/8-inch sheet metal screws to secure the hubs together. Check the rotation of the wheel when installing the screws. If the wheel does not rotate, loosen the screws slightly until it does.



Step 7

Use a 4-40 setscrew to secure the axle to the main landing gear.



Note: Use threadlock on the setscrew to prevent them from vibrating loose in flight.

Step 8

To complete the wheel installation, snap the hub cap onto the wheel.



Step 9

Repeat Steps 3 through 8 to install the remaining wheel.

Stabilizer Installation

Required Parts

- Fuselage assembly
- Stabilizer/elevator (2)
- 6³/₈-inch (162mm) joiner
- #6 washer (4)
- Tail wheel assembly
- 2-56 nut (4)
- 4-40 locknut (3)
- Large strut support bracket (2)
- Small strut support bracket (2)
- #6 x 5/8-inch sheet metal screws (2)
- 4-40 x 5/8-inch socket head screw (3)
- Support rod w/clevis, 10-inch (254mm) (2)
- Support rod w/clevis, 9¹/₂-inch (241mm) (2)
- 6-32 x 3/4-inch socket head screw (4)

Required Tools and Adhesives

- Threadlock
- Hex wrench: 3/32-inch, 7/64-inch

□ Step 1

Slide the 6³/₈-inch (162mm) joiner into the forward hole in the stabilizer.

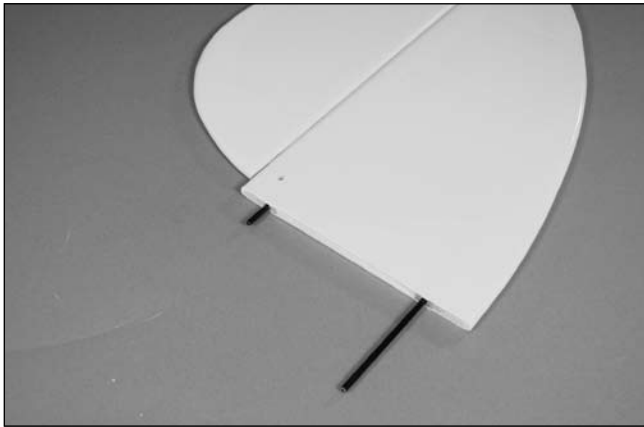

□ Step 2

Slide the stabilizer into the slot in the fuselage. Use two 6-32 x 3/4-inch socket head screws and two #6 washers to secure the stabilizer.



Note: Leave the screws loose until instructed to tighten them.

□ Step 3

Slide the remaining stabilizer into the slot in the fuselage. The tubes from the first stabilizer will key into the second stabilizer. Use two 6-32 x 3/4-inch socket head screws and two #6 washers to secure the stabilizer. Once all four screws have been started, tighten each one, but avoid crushing the underlying wood.



Note: Use threadlock on the four 6-32 screws to prevent them from vibrating loose in flight.

Stabilizer Installation

□ Step 4

Attach the tail wheel assembly to the fuselage using two #6 x 5/8-inch sheet metal screws. The forward screw goes through the gear and into the fuselage, while the rear screw goes through the two large strut support brackets, then through the gear and into the fuselage.



□ Step 5

Attach the two small strut support brackets to the fin using a 4-40 x 5/8-inch socket head screw and a 4-40 locknut. There will be a bracket on the right and left of the fin when complete.



□ Step 6

Remove the clevis from each of the support rods. Use a hobby knife to clean the paint from the threads. Thread a 2-56 nut onto the threads, then replace the clevis.

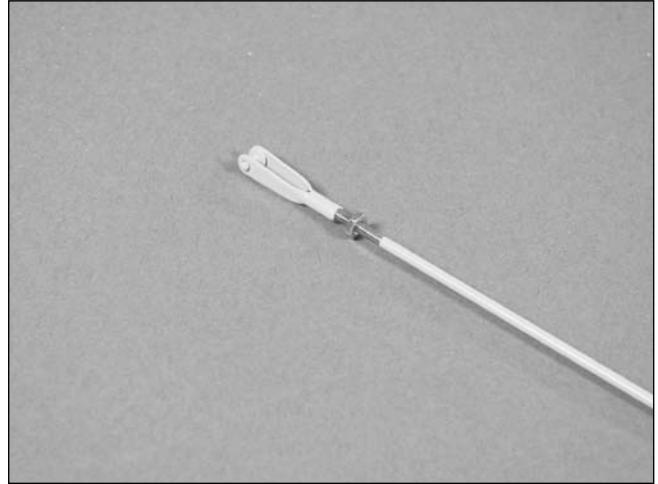

□ Step 7

Use a 4-40 x 5/8-inch socket head screw and 4-40 locknut to attach the support rods to the stabilizer. The longer 10-inch (254mm) rod attaches to the top of the stabilizer, while the shorter 9 1/2-inch (241mm) rod attaches to the bottom of the stabilizer.



Stabilizer Installation

□ Step 8

Clip the clevis to the strut support bracket. It will be necessary to adjust the position of the clevis to ensure the support rods are not causing any twists between the fuselage, stabilizer and fin. Tighten the nuts against the clevises once all adjustments have been made.



Note: Use threadlock on the nuts and clevises to prevent them from vibrating loose in flight.

Aileron Servo Installation

Required Parts

- 4-40 metal clevis (4)
- 4-40 nut (4)
- Wing panel (right and left)
- Servo hatch cover (right and left)
- 2-56 x 1-inch machine screw (6)
- 4 $\frac{3}{4}$ -inch (120mm) pushrod (2)
- #2 x 1/2-inch sheet metal screw (8)
- Nylon control horn w/backplate (2)
- 3/4 x 11/16 x 7/16-inch (19 x 17 x 11mm) servo mounting blocks (4)
- Safety fuel tubing (4)

Required Tools and Adhesives

- Drill
- Servo (2)
- String
- Phillips screwdriver
- Felt-tipped pen
- Thin CA
- 18-inch (457mm) servo extension (2)
- Drill bit: 1/16-inch (1.5mm), 5/64-inch (2mm)
- 30-minute epoxy
- Long servo arm
- Weight
- Threadlock
- Tape

□ □ Step 1

Locate the servo hatch cover and test fit it into position. There is a right and left cover, so make sure when the hatch is positioned, the slot for the servo arm lines up.

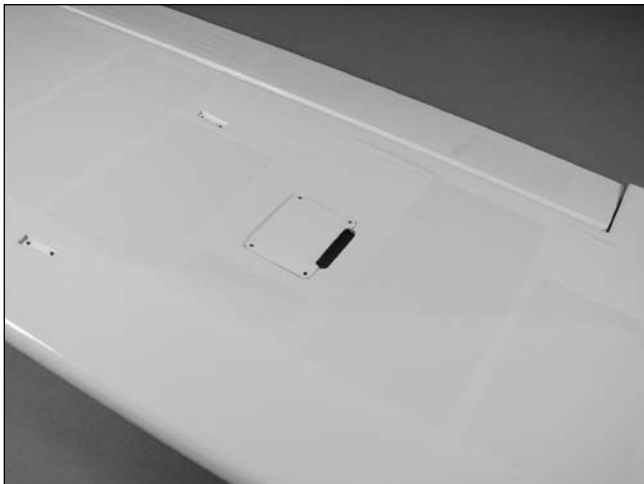

□ □ Step 2

Install a long servo arm onto the aileron servo. Remove the excess arms that will not extend out from the wing. Position the servo so the arm is centered in the opening for the arm. Use a felt-tipped pen to mark the location of the servo on the cover.

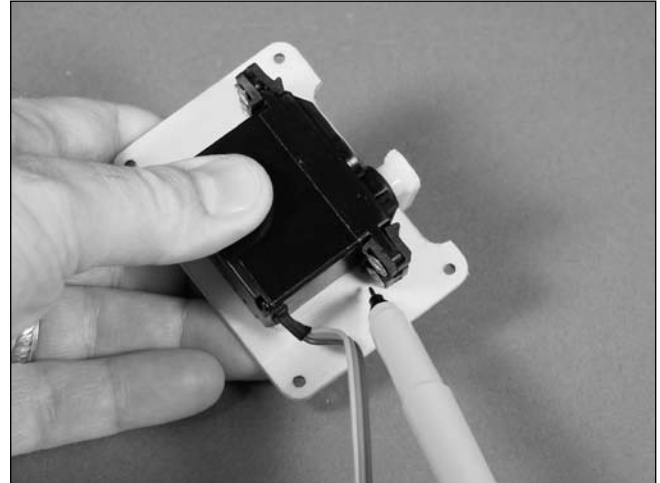

Note: The mounting tabs for the servo must not extend beyond the servo cover. If so, reposition the servo before marking its location on the servo cover.

□ □ Step 3

Locate two of the 3/4 x 11/16 x 7/16-inch (19 x 17 x 11mm) servo mounting blocks. Position the blocks so they align with the marks made in the previous step. Use 30-minute epoxy to glue the blocks to the cover. Allow the epoxy to fully cure before proceeding.

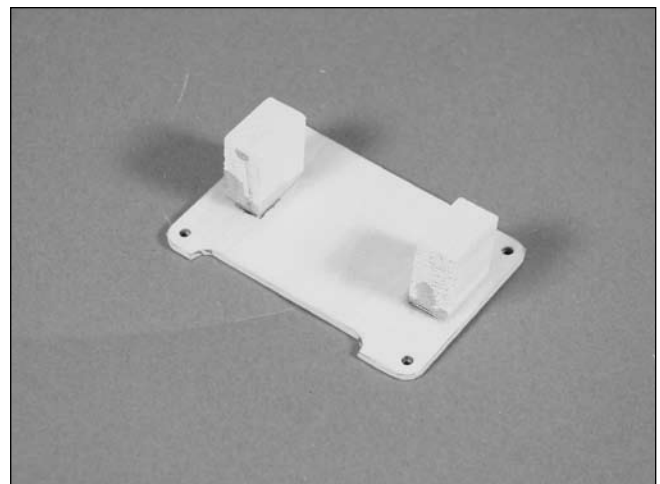

Aileron Servo Installation

□ Step 4

Repeat steps 1 through 3 to prepare the remaining cover while the epoxy cures.

□ □ Step 5

Position the servo between the block and with a small space between the servo and cover. Use a felt-tipped pen to mark the locations for the servo mounting screws onto the blocks.

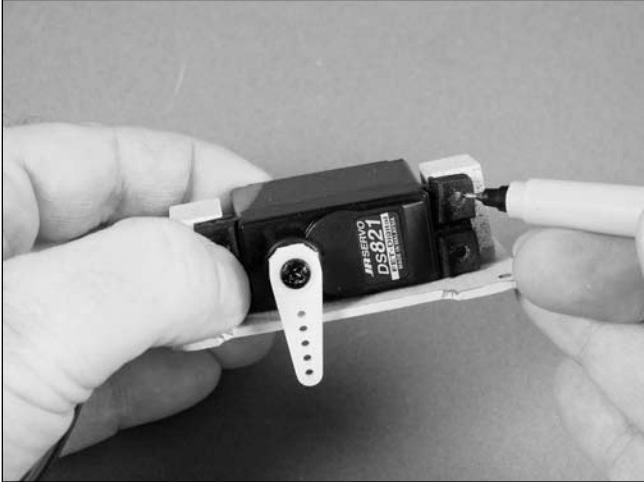

□ □ Step 6

Drill the marked locations using a drill and 1/16-inch (1.5mm) drill bit. Use the hardware provided with the servo to secure it to the blocks.

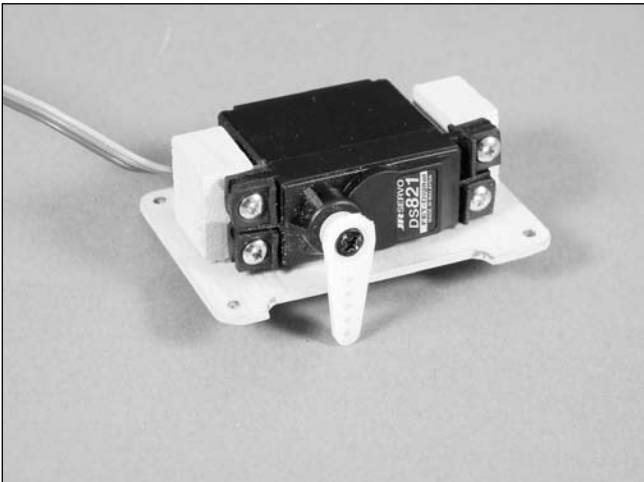

□ □ Step 7

Use string or a commercially available connector to secure a 18-inch (457mm) servo extension to the servo lead.

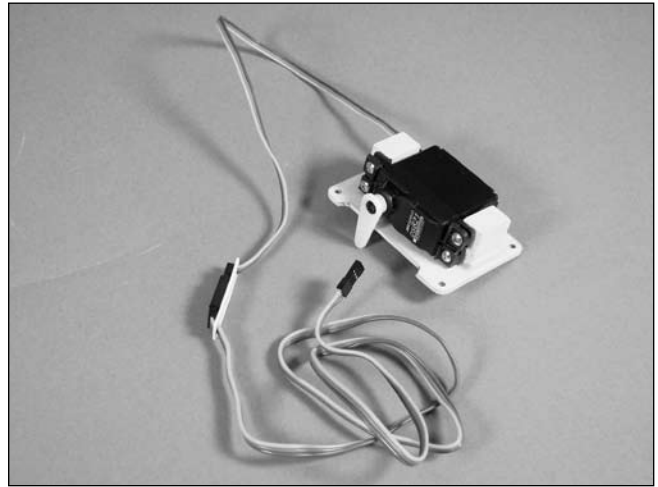

□ □ Step 8

Tie a weight to a 24-inch (610mm) piece of string. Lower the weight into the wing and pull it out at the opening for the servo cover.

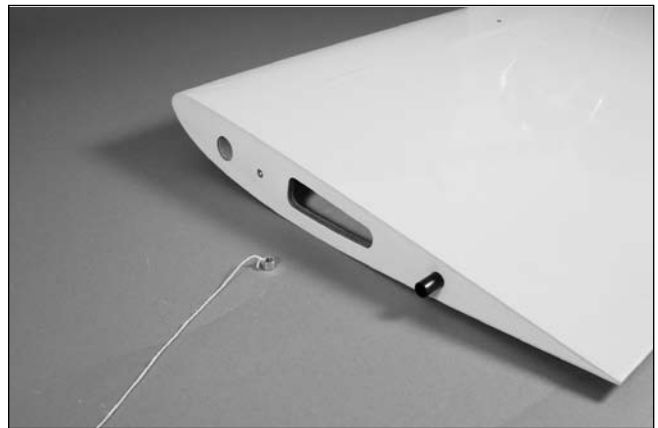

Aileron Servo Installation

□ □ Step 9

Tie the string to the end of the servo extension and use it to pull the extension through the wing. Use a piece of tape to keep the extension from falling back into the fuselage.

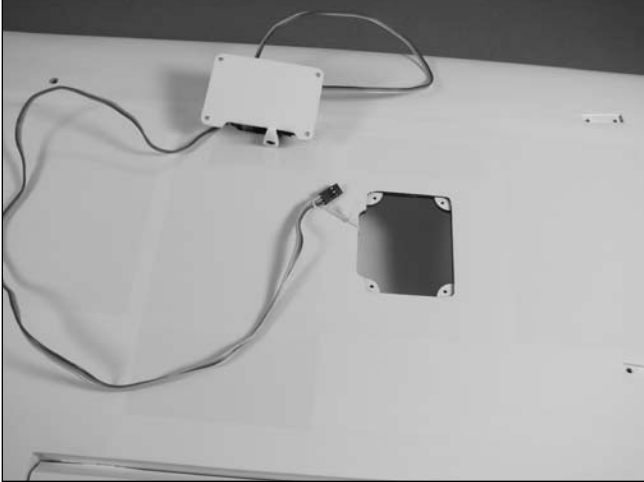

□ □ Step 10

Position the servo hatch cover and secure it using four #2 x 1/2-inch sheet metal screws. After installing the screws, remove them and apply a few drops of thin CA to the holes to harden the wood to prevent the screws from vibrating loose.



□ □ Step 11

Assemble the aileron pushrod by sliding the safety fuel tubing onto two metal clevises. Thread the two metal clevises and two 4-40 nuts onto a 4 3/4-inch (120mm) pushrod.

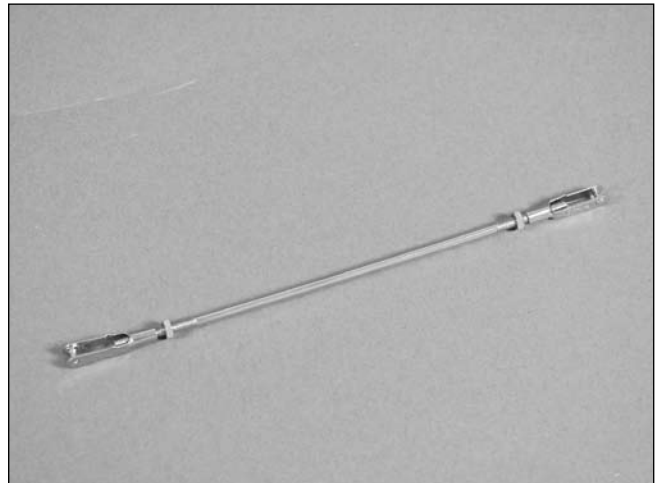

Aileron Servo Installation

□ □ Step 12

Attach one end of the linkage to the servo horn. Remove the backplate from a nylon control horn and attach the other end of the linkage to the horn. Position the horn on the aileron with the holes in the horn aligned with the hinge line of the aileron. Use a felt-tipped pen to mark the location for the three control horn mounting screws.

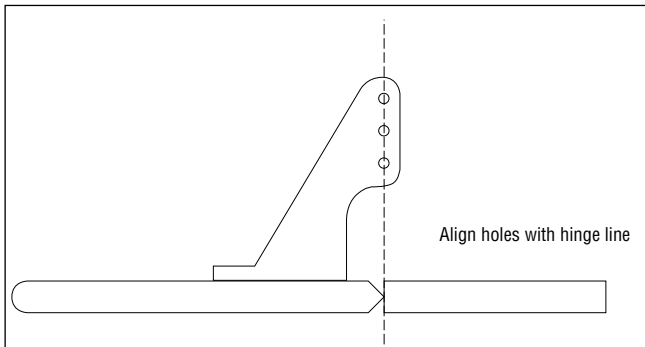

□ □ Step 13

Use a 5/64-inch (2mm) drill bit to drill the three holes for the control horn screws. Apply a few drops of thin CA into each hole to harden the wood to aid in preventing the wood from being crushed when the horn is installed.



□ □ Step 14

Secure the control horn to the aileron using three 2-56 x 1-inch machine screws and the control horn backplate.

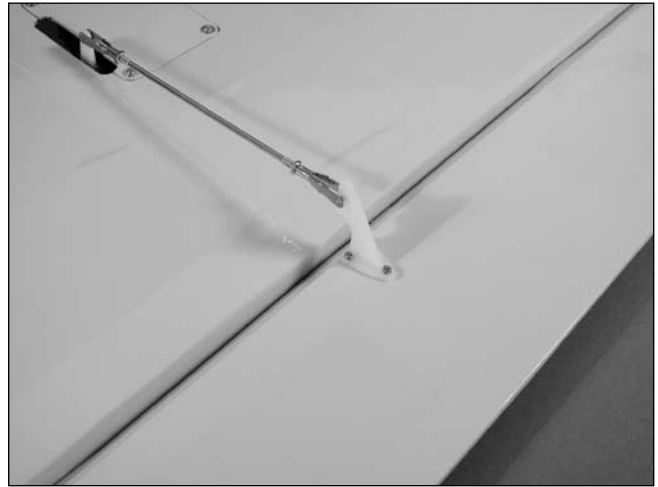

Note: Once the length of the linkage has been adjusted, use threadlock on the nuts and clevises to prevent them from vibrating loose in flight.

□ □ Step 15

Repeat Steps 5 through 14 to install the remaining aileron servo and linkage.

Radio Installation

Required Parts

- Fuselage assembly
- Metal clevis (4)
- Rigging couplers (4)
- 2-56 nuts (3)
- Rudder tiller bracket
- Safety fuel tubing (4)
- Rado tray cover
- 2-56 x 5/8-inch machine screw (9)
- Hook and loop strap (2)
- #2 x 5/8-inch sheet metal screw (4)
- 33 1/4-inch (845mm) elevator pushrod (2)
- 4-40 ball end w/hardware (4)
- Control horn w/backplate (4)
- 4-40 nut (4)
- Rudder cable
- Cable crimps (4)
- Rudder spring (2)
- Radio tray cover

Required Tools and Adhesives

- Drill
- Threadlock
- Felt-tipped pen
- Crimping tool/vice grips
- 1/4-inch (6mm) foam
- Drill bit: 1/16-inch (1.5mm), 5/64-inch (2mm)
- Large servo arm (3)
- Hobby knife
- Thin CA
- Pliers

□ □ Step 1

Locate the 33 1/4-inch (845mm) elevator pushrod and a 4-40 ball end. Thread the ball end onto one end of the rod a minimum of 14 turns.



□ □ Step 2

Attach the ball end to a large servo horn. Use side cutters to remove the remaining arm from the horn.

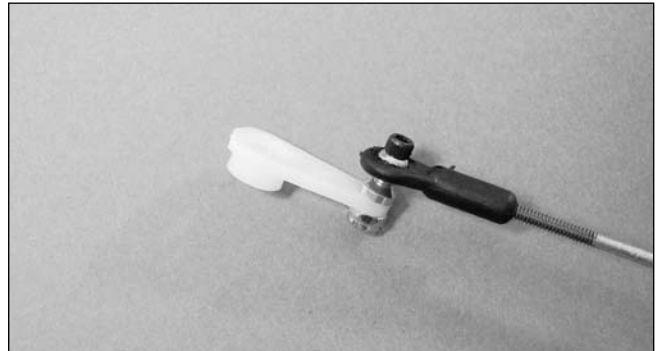

□ □ Step 3

Slide the pushrod into the elevator pushrod tube inside the fuselage. You will need to trim the covering from the pushrod exit using a hobby knife.



□ □ Step 4

Slide a piece of safety fuel tubing onto a metal clevis. Thread a 4-40 nut and metal clevis onto the pushrod.



□ □ Step 5

Remove the backplate from a control horn. Attach the clevis to the horn and position the horn on the elevator with the holes in the horn aligned with the elevator hinge line. The horn centerline will be 1-inch (25mm) from the edge of the stabilizer to avoid interference between the control linkage and mounting tabs. Use a felt-tipped pen to mark the positions for the three control horn mounting screws.

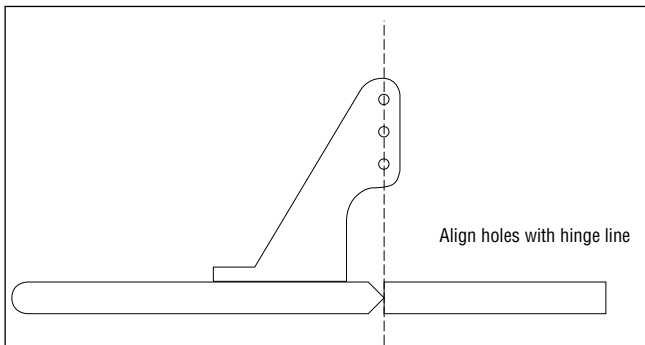

□ □ Step 6

Use a 5/64-inch (2mm) drill to drill through the elevator for the control horn mounting screws.



□ □ Step 7

Apply a few drops of thin CA into each of the holes to harden the surrounding wood.



□ □ Step 8

Attach the control horn to the elevator using three 2-56 x 5/8-inch machine screws and the control horn backplate.



Note: Once the length of the linkage has been adjusted; use threadlock on the nuts and clevises to prevent them from vibrating loose in flight.

Radio Installation

□ □ Step 9

Install the elevator servo into the fuselage. The output arm on the servo faces toward the rear of the fuselage. Secure the servo horn to the servo using the hardware provided with the servo.



□ Step 10

Repeat Steps 1 through 9 to install the remaining elevator servo.

Note: Using two standard rotation servos and a standard Y-harness for the elevator servos will result in them moving in opposite directions instead of the same direction. There are three options available that will result in the elevators operating correctly.

Option 1: Use two standard rotation servos if your radio has programmable mixing. You will need to use two separate channels and use your radio to mix them together electronically for this option to work.

Option 2: Use two servos and a JR® MatchBox™ or a 6" standard reversing Y-harness (EXRA320) to link the two elevator servos to operate properly.

Option 3: Use a standard rotation servo and a reverse rotation servo and a standard Y-harness.

Note: The cable will be installed into the fuselage from the tail to make the servo end of the cable easier to install, and to keep it from falling into the fuselage while installing the ends and servo.

□ □ Step 11

Locate the rudder cable and insert one end of the cable into the fuselage. Make sure the cable does not get tangled around any of the formers on its way to where the rudder servo will be installed.

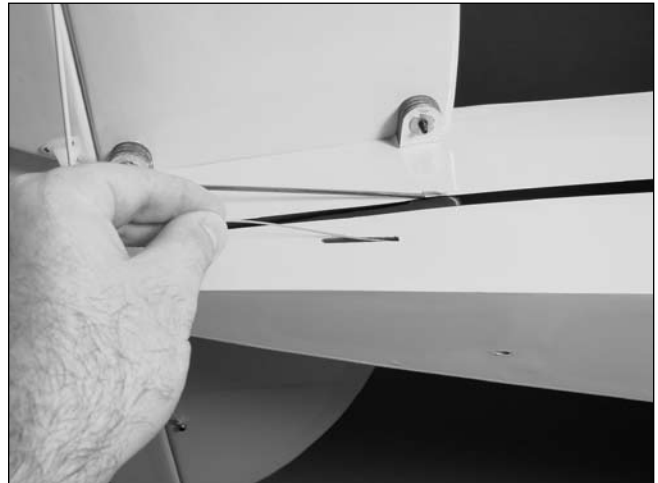

□ □ Step 12

Thread a rigging coupler into one of the 4-40 ball ends. Slide a crimp onto the cable, then pass the cable through the rigging coupler. The cable then goes back through the crimp. Use a crimping tool or vice grips to secure the crimp to the cable.



□ □ Step 13

Repeat Steps 11 and 12 to prepare the other end of the cable.

□ Step 14

Attach the ball ends to the servo horn using the hardware included with the ball ends.

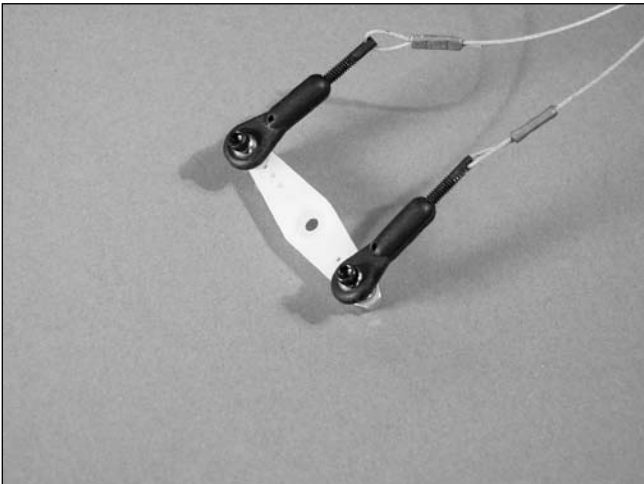

□ Step 15

Install the rudder servo into the fuselage and attach the servo horn to the servo using the hardware provided with the servo. The output of the servo faces the front of the fuselage. Note that the cables cross once inside the fuselage: The cable from the right side of the servo exits the left of the fuselage and vice versa.



□ Step 16

Place light tension on the cable and align it so it is centered in the exit opening. The rudder control horn centerline should be 7/8-inch (22mm) from the bottom of the rudder. Mark the rudder where the cable crosses with a felt-tipped pen.



Radio Installation

□ Step 17

The rudder uses two control horns mounted on either side. Position one horn so it is aligned with the mark made in the previous step. Mark and drill the holes for the control horn screws, then mount the horns. The three 2-56 x 5/8-inch machine screws go through the first control horn, through the rudder, through the second horn and are then secured using three 2-56 nuts.

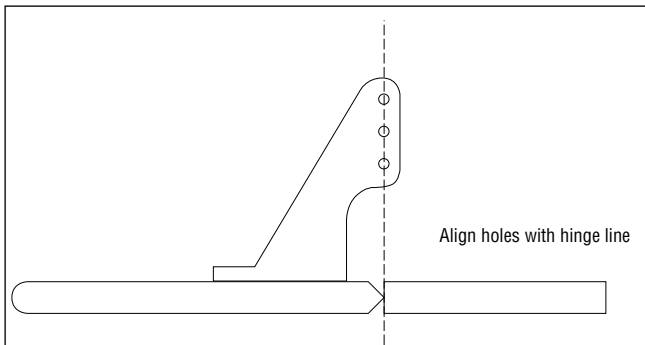

Note: Use threadlock on the nuts to prevent them from vibrating loose in flight.

□ □ Step 18

Slide a piece of safety tubing on a metal clevis. Thread a 4-40 nut and metal clevis onto a rigging coupler. Slide a crimp onto the cable, then slide the cable through the coupler. The cable will then go back through the crimp. Prepare both ends of the cable and attach the clevises to the control horns. Adjust the cable so there is light tension on the cable, then secure the cable using the crimp and crimping pliers or vice grips. Make sure to install that safety fuel tubing on those clevises.



Note: Once the length of the cable has been adjusted, use threadlock on the nuts and clevises to prevent them from vibrating loose in flight.

□ Step 19

Attach the rudder tiller bracket to the rudder using two #2 x 5/8-inch sheet metal screws. It is highly suggested to remove the screws, then apply a few drops of thin CA into the holes and reinstall the screws.



□ Step 20

Connect the rudder tiller bracket to the tailwheel steering arm using the two rudder springs. You will need to bend the springs to attach them on each end using pliers.



□ Step 21

Wrap the receiver battery and receiver in 1/4-inch (6mm) foam. Attach the receiver and receiver battery to the radio tray using hook and loop straps.

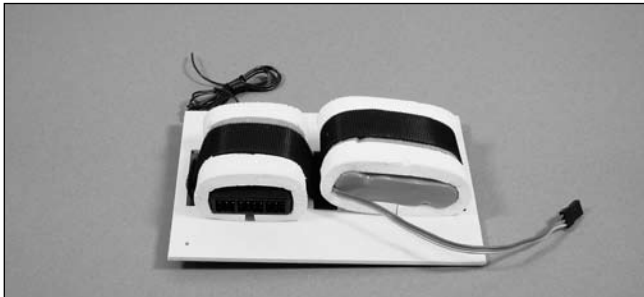

□ Step 22

Slide the radio tray into the fuselage and secure its position using two #2 x 1/2-inch sheet metal screws.



□ Step 23

Install a choke ring (JRPA029) on each of the the 18-inch (457mm) aileron extensions that are plugged into the receiver. These will be hidden under the radio tray. This is strongly recommended due to all the metal struts on the Cub.



□ Step 24

Plug two 18-inch (457mm) servo extensions into the receiver and route them through the holes in the sides of the fuselage and up to the top of the fuselage. Slide the radio tray cover into position so it locks into position under the rear cabin wall. Use two #2 x 1/2-inch sheet metal screws to secure the radio tray cover inside the fuselage.



Engine Installation (Glow)

Required Parts

- Fuselage assembly
- Engine mount (2)
- 8-32 locknut (4)
- Throttle pushrod tube
- Battery cover
- 8-32 blind nut (4)
- Cowl screw fuel tubing (4)
- 4-40 x 1/2-inch socket head screw (4)
- #2 x 1/2-inch sheet metal screw (2)
- Threaded rod, 1-inch (25mm) (2)
- 8-32 x 1 1/4-inch socket head screw (4)
- 8-32 x 1 1/2-inch socket head screw (4)
- Firewall template
- #8 washer (12)
- Throttle pushrod
- Metal clevis (2)
- #4 washer (4)

Required Tools and Adhesives

- Drill
- Clamp
- Phillips screwdriver
- Hex wrench: 3/32-inch, 9/64-inch
- Drill bit: 1/16-inch (1.5mm), 5/32-inch (4mm), 3/16-inch (4.5mm)
- Threadlock
- Medium CA

□ Step 1

Place the firewall template in position on the firewall. Drill the locations for your particular engine using a 1/16-inch (1.5mm) drill bit. Drill the location for the throttle pushrod at this time as well.



□ Step 2

Remove the template and enlarge the holes using a 3/16-inch (4.5mm) drill bit.

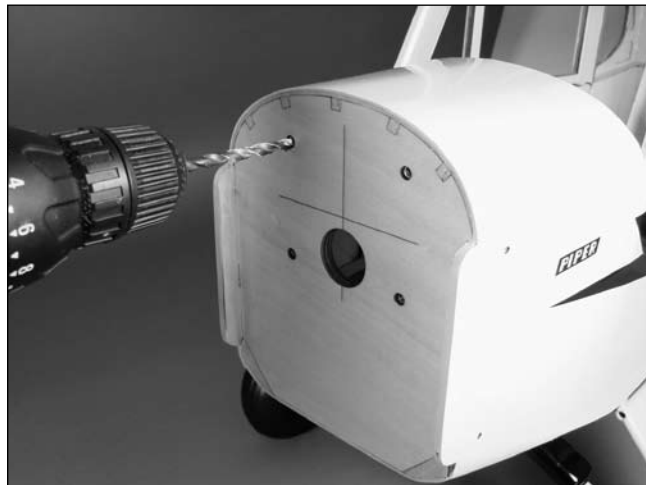

□ Step 3

Secure the engine mounts to the firewall using four 8-32 blind nuts from the inside of the fuselage, and four 8-32 x 1 1/4-inch socket head screws and four #8 washers.



Engine Installation (Glow)

□ Step 4

Position the engine on the mount so the drive washer is 6 inches (152mm) forward of the firewall. Clamp the engine to the mount and transfer the locations for the engine mounting bolts onto the engine mounts.

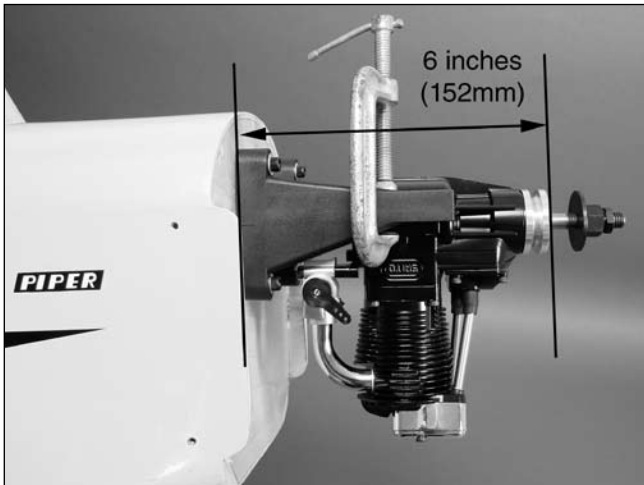

□ Step 5

Drill the locations for the engine mounting screws using a drill and 5/32-inch (4mm) drill bit.



□ Step 6

Slide the throttle pushrod tube into the hole drilled in the firewall. The tube will extend forward of the firewall slightly. Use medium CA to glue the tube to the firewall.



Note: It may be necessary to rotate the carburetor to align with the throttle pushrod tube. Check the alignment before attaching the engine to the engine mount.

□ Step 7

Use four 8-32 x 1 1/2-inch socket head screws, four 8-32 locknuts and eight #8 washers to secure the engine to the mount.

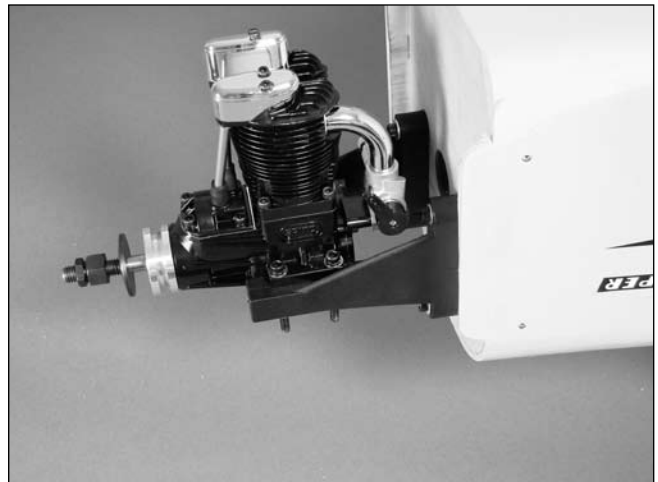

Engine Installation (Glow)

□ Step 8

Thread a 1-inch (25mm) threaded rod into each end of the throttle pushrod. Thread a metal clevis onto one of the threaded rods and slide the pushrod into the pushrod tube. Attach the clevis to the arm of the carburetor.

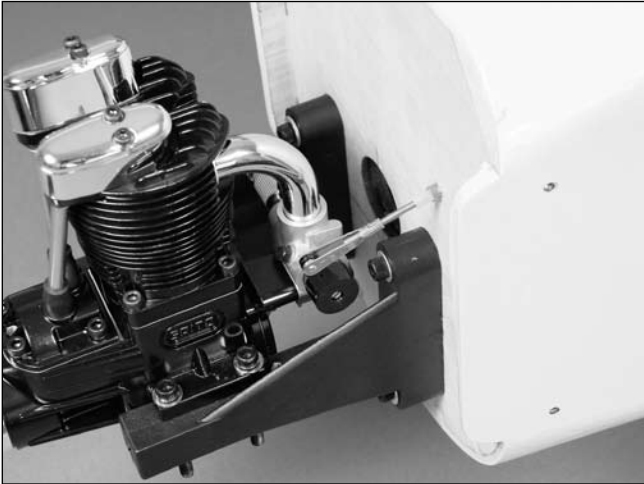

□ Step 9

Secure the throttle servo in the fuselage using the hardware provided with the servo. Thread a clevis onto the threaded rod and attach the clevis to the servo arm.

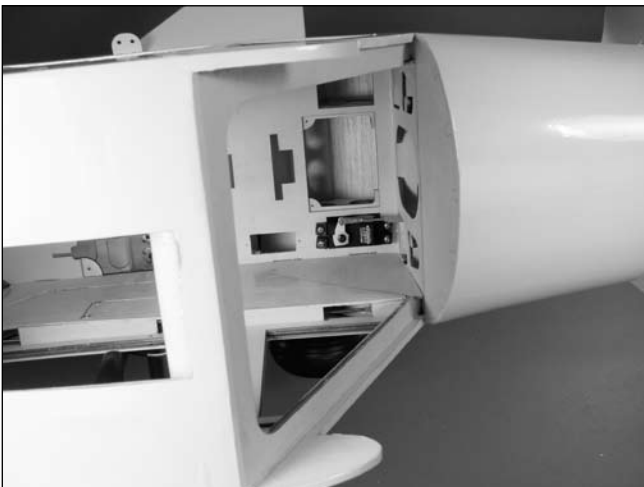

□ Step 10

Check the operation of the throttle servo to make sure it doesn't bind and the throttle will move from open to closed. Make any adjustment at this time to the throttle linkage as necessary.

□ Step 11

Slide the fuel tank into the fuselage with the stopper facing toward the top of the fuselage. Use a rubber band to keep the fuel tank from moving rearward in the fuselage.



□ Step 12

Use two #2 x 1/2-inch sheet metal screws to secure the battery cover in position behind the fuel tank.



Engine Installation (Glow)

□ Step 13

Install the muffler and connect the fuel lines from the tank to the engine.



Note: We used a fuel dot and T-fitting on our model so the cowl won't have to be removed to fuel the engine.

Note: You will need to use a Muffler Right Angle Adapter (SAI120S140) when installing the Saito engines.

□ Step 14

Attach the cowling using four 4-40 x 1/2-inch socket head screws, four pieces of cowl screw tubing and four #4 washers. Install the propeller to complete the engine installation.



Engine Installation (Gas)

Required Parts

- Fuselage assembly
- Throttle pushrod tube
- Battery cover
- Cowl screw tubing (4)
- Fender washer (4)
- Ignition switch (JRPA004)
- 10-32 x 5/8-inch bolt (4)
- 4-40 x 1/2-inch socket head screw (4)
- #2 x 1/2-inch sheet metal screw (2)
- Threaded rod, 1-inch (25mm) (2)
- 38mm engine stand-offs (EVO3307)
- Firewall template
- Metal clevis (2)
- #4 washer (4)
- Throttle pushrod

Required Tools and Adhesives

- Drill
- Clamp
- Phillips screwdriver
- Hex wrench: 3/32-inch, 9/64-inch
- Drill bit: 1/16-inch (1.5mm), 3/16-inch (4.5mm)
- Medium CA
- Threadlock

□ Step 1

Place the firewall template in position on the firewall. Drill the locations for your particular engine using a 1/16-inch (1.5mm) drill bit. Drill the location for the throttle pushrod at this time as well.



□ Step 2

Remove the template and enlarge the holes using a 3/16-inch (4.5mm) drill bit.

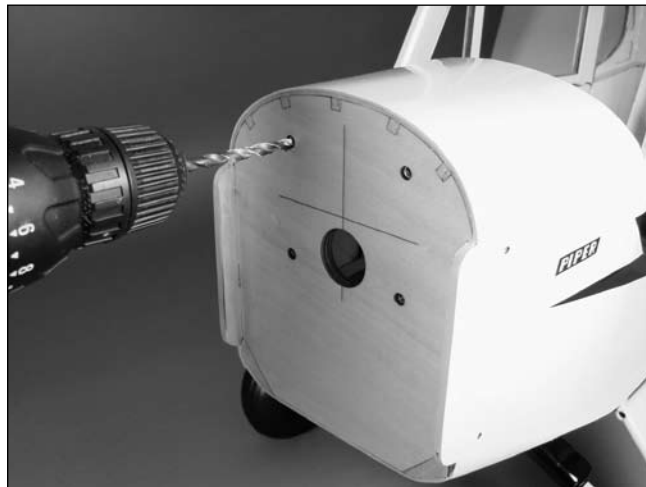

□ Step 3

Slide the throttle pushrod tube into the hole drilled in the firewall. The tube will extend forward of the firewall slightly. Use medium CA to glue the tube to the firewall.

□ Step 4

Attach the engine and accessories to the firewall as shown in the following photos.



Engine Installation (Gas)

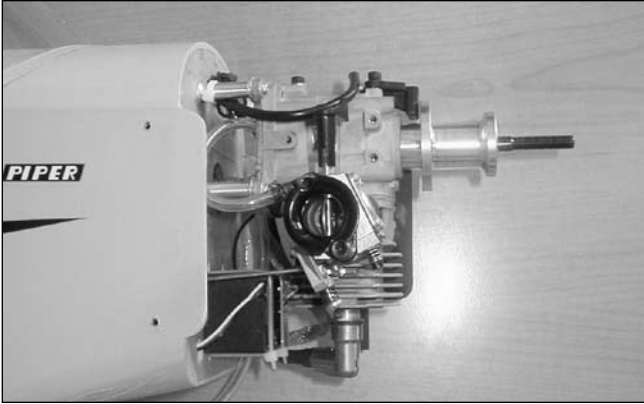

□ Step 5

Secure the throttle servo in the fuselage using the hardware provided with the servo. Thread a clevis onto the threaded rod and attach the clevis to the servo arm.



Note: When using a gas engine it is recommended that an RF choke ring (JRPA029) be used. The servo lead must make 3 passes around or through the ring.

□ Step 6

Remove the stopper from the fuel tank using a Phillips screwdriver. Remove the fuel lines from the stopper and set them aside. Prepare the tubing by placing a drop of solder on the ends of the brass tubing as shown. This will keep the fuel line from slipping off the tube when combined with the following steps.

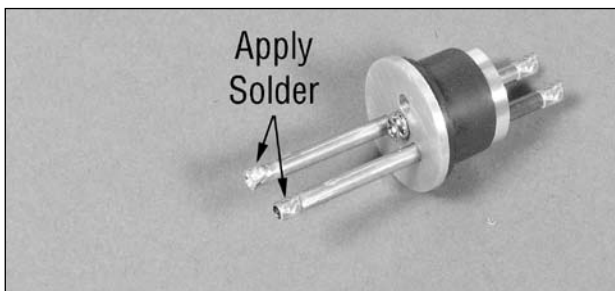

□ Step 7

Slide gas compatible fuel lines back onto the brass tubes. Use fine wire to secure the fuel lines. The wire is placed behind the solder applied in the previous step to keep the tubes in place.



□ Step 8

Carefully insert the stopper assembly into the fuel tank. Note the position of the vent tube; it must be up at the top portion of the fuel tank to function properly. Tighten the screw carefully—do not over-tighten.

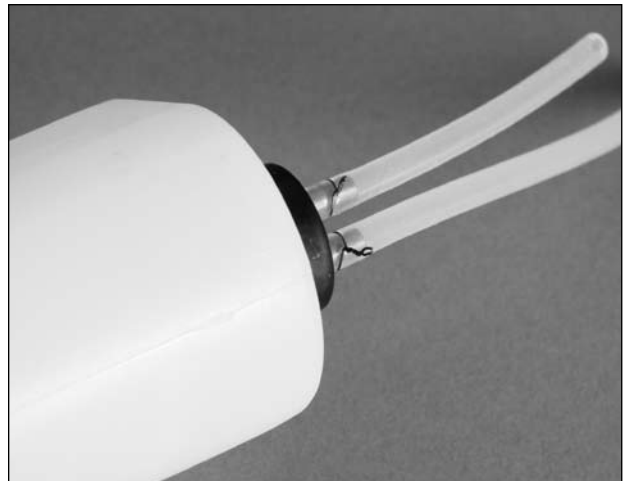

Engine Installation (Gas)

□ Step 9

Slide the fuel tank into the fuselage with the stopper facing toward the top of the fuselage. Use a rubber band to keep the fuel tank from moving rearward in the fuselage.



□ Step 10

Use two #2 x 1/2-inch sheet metal screws to secure the battery cover in position behind the fuel tank.



The ignition battery should be placed next to the fuel tank behind the firewall. This is to keep as much separation between the ignition and the RX.

The battery pack should be installed before installing the fuel tank. The model was flown with the battery pack placed here when using the Zenoh 20ei.

□ Step 11

Trim the cowling as necessary to clear the muffler, carburetor and head of the engine. Secure the cowling using four 4-40 x 1/2-inch socket head screws, four pieces of cowl screw tubing and four #4 washers.

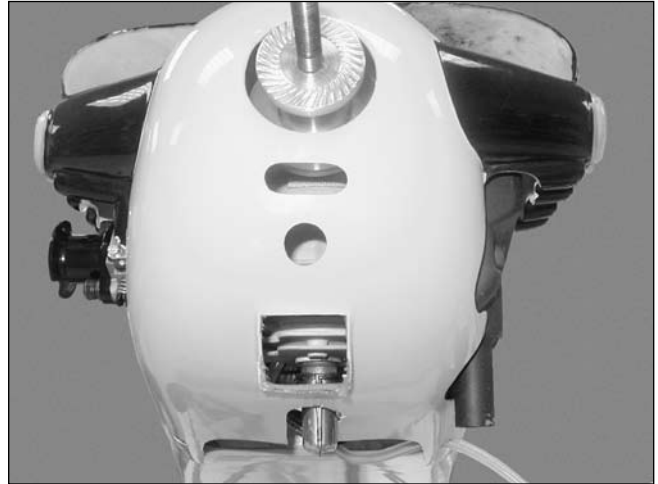

Interior Detail Installation

Required Parts

- Fuselage assembly
- Side window (left and right)
- Front seat bottom
- Rear seat bottom
- Floor
- Windscreen supports
- Pilot
- #2 x 1/2-inch sheet metal screw (4)
- Front windscreen
- Upper window
- Front seat back
- Rear seat back
- Instrument panel
- Hook and loop

Required Tools and Adhesives

- Switch harness
- Phillips screwdriver
- Hobby scissors
- Canopy glue
- Medium CA
- Hobby knife
- 30-minute epoxy

□ Step 1

Install the switch harness into the opening in the rear seat bottom.

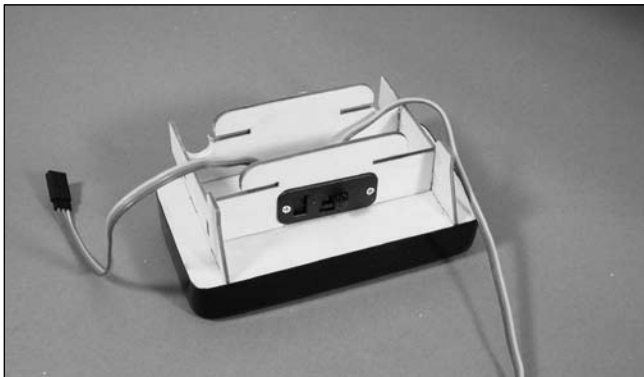

□ Step 2

Use medium CA to glue the rear seat back to the rear seat bottom.



□ Step 3

Plug the switch harness into the battery and receiver. Slide the rear seat into position, guiding the wires from the switch harness behind the seat.



□ Step 4

Glue the front seat back to the front seat bottom. Slide the front seat into position.



Interior Detail Installation

Step 5

Use four #2 x 1/2-inch sheet metal screws to secure the floor into the fuselage. The floor will keep the seats from sliding in the fuselage.



Step 6

Use medium CA to glue the instrument panel into the fuselage.



Step 7

Use 30-minute epoxy to glue the windscreen supports into position as shown.



Step 8

Use canopy glue to glue the front windscreen onto the fuselage as shown.



Interior Detail Installation

□ □ Step 9

Use a hobby knife and hobby scissors to trim the side windows. Use canopy glue to attach the side windows into position.



□ □ Step 10

Trim the rear window and use canopy glue to secure the rear window in position.



□ Step 11

Repeat Steps 9 and 10 for the opposite side windows.

□ Step 12

Complete the window installation by trimming and installing the upper window in the fuselage.



□ Step 13

Use hook and loop to secure the pilot in the fuselage.



Wing Installation

Required Parts

- Wing (left and right)
- Mid-span stud (4)
- Wing strut end (4)
- Retainer clip (8)
- Wing strut wing bracket
- 1/4-20 nylon wing bolt (2)
- Mid-span cross brace (2)
- 4-40 x 3/4-inch socket head screw (8)
- 4-40 x 3/8-inch socket head screw (4)
- 4-40 x 1/2-inch socket head screw (4)
- Front wing strut (left and right)
- Rear wing strut (left and right)
- Short strut pin (4)
- 4mm nut (4)
- Long strut pin (4)
- Aluminum wing tube
- 4-40 locknut (8)

Required Tools and Adhesives

- Hex wrench: 3/32-inch
- Threadlock
- Nut driver: 1/4-inch

□ □ Step 1

Attach the wing strut wing brackets to the bottom of the wing using four 4-40 x 3/4-inch socket head screws.



Note: Use threadlock on the screws to prevent them from vibrating loose in flight.

□ □ Step 2

Thread two of the mid-span studs into the wing. The threads of the studs should be flush to the top of the wing.



□ □ Step 3

Attach the front and rear wing strut to the brackets using four 4-40 x 1/2-inch socket head screws and 4-40 locknuts.



Note: The wide strut goes toward the leading edge, the narrow strut toward the trailing edge. The airfoil on the struts will match the wing as well when they are installed.

Wing Installation

□ □ Step 4

Thread the wing strut ends and 4mm nuts on the ends of the struts.



□ □ Step 5

Install the mid-span supports and cross brace as shown. The brace and supports attach using two 4-40 x 3/8-inch socket head screws and 4-40 locknuts. The supports attach to the mid-span studs using two long strut pins and two retainer clips.



□ □ Step 6

Slide the aluminum wing tube into the fuselage. The wing is then slid onto the wing tube. Plug the servo lead in the wing into the extension inside the fuselage.



□ □ Step 7

The wing is held in place using a 1/4-20 nylon wing bolt.



Wing Installation

□ □ Step 8

Confirm that there is a piece of tubing on the pin before inserting it into the brace. If not, install a piece of tubing to prevent vibration and radio interference. Slide the short pins from the strut ends into the brace at the fuselage. It will be necessary to adjust the strut ends to align without binding or twisting the wing. Once adjusted, tighten the 4mm nuts against the ends to prevent them from changing position.

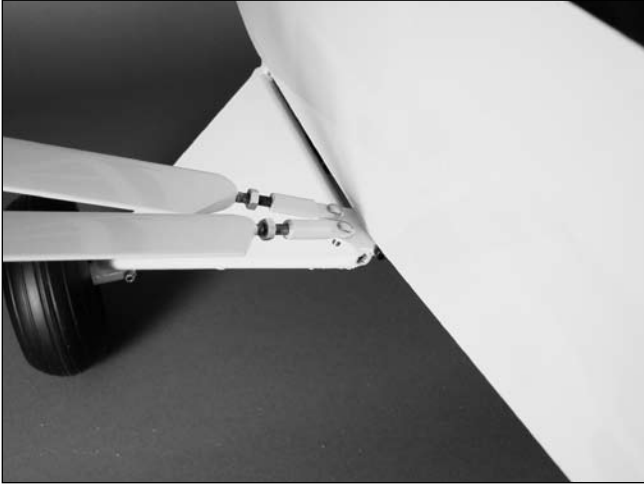

Note: Use threadlock on the strut ends and 4mm nuts to prevent them from vibrating loose in flight.

□ □ Step 9

Secure the strut ends to the wing using two retainer pin clips.



Control Throws

The amount of control throw should be adjusted as closely as possible using mechanical means, rather than making large changes electronically at the radio. By moving the position of the clevis at the control horn toward the outermost hole, you will decrease the amount of control throw of the control surface: moving it toward the control surface will increase the amount of throw; moving the pushrod wire at the servo arm will have the opposite effect. Moving it closer to center will decrease throw, and away from center will increase throw. Work with a combination of the two to achieve the closest or exact control throws listed.

Aileron:

High Rate: $1\frac{1}{8}$ -inch (28mm) up
 $1\frac{1}{8}$ -inch (28mm) down
Low Rate: $\frac{3}{4}$ -inch (19mm) up
 $\frac{3}{4}$ -inch (19mm) down

Note: Aileron throw is measured at the trailing edge of the aileron nearest the fuselage.

Elevator:

High Rate: 2-inch (51mm) up/down
Low Rate: $1\frac{1}{4}$ -inch (32mm) up/down

Note: Elevator throw is measured at the trailing edge of the elevator next to the fuselage.

Rudder:

High Rate: $2\frac{1}{4}$ -inch (57mm) left/right
Low Rate: $1\frac{1}{2}$ -inch (38mm) left/right

Note: Rudder throw is measured at the bottom of the rudder.

Recommended Center of Gravity (CG)

An important part of preparing the aircraft for flight is properly balancing the model. This is especially important when various engines are mounted.

Caution: Do not inadvertently skip this step!

The recommended Center of Gravity (CG) location for the Piper J-3 Cub is CG: $4\frac{1}{2}$ inches (114mm) back from leading edge of wing at the root rib. Mark the location of the CG onto the bottom of the wing using a felt-tipped pen. Make sure the aircraft is upright when checking the CG. If the nose of your aircraft hangs low, add weight to the rear of the aircraft. If the tail hangs low, add weight to the nose of the aircraft. Stick-on weights are available at your local hobby store and work well for this purpose. The CG Range for your Piper J-3 Cub is $4-4\frac{3}{4}$ inches (102mm–120mm) back from leading edge of wing at the root rib.



Pre-Flight

Charge both the transmitter and receiver pack for your airplane. Use the recommended charger supplied with your particular radio system, following the instructions provided with the radio. In most cases, the radio should be charged the night before going out flying.

Check the radio installation and make sure all the control surfaces are moving correctly (i.e. the correct direction and with the recommended throws). Test run the engine and make sure it transitions smoothly from idle to full throttle and back. Also ensure the engine is tuned according to the manufacturer's instructions, and it will run consistently and constantly at full throttle when adjusted.

Check all the control horns, servo horns and clevises to make sure they are secure and in good condition. Replace any items that would be considered questionable. Failure of any of these components in flight would mean the loss of your aircraft.

Adjusting the Engine

Step 1

Completely read the instructions included with your engine and follow the recommended break-in procedure.

Step 2

At the field, adjust the engine to a slightly rich setting at full throttle and adjust the idle and low-speed needle so that a consistent idle is achieved.

Step 3

Before you fly, be sure that your engine idles reliably, transitions and runs at all throttle settings. Only when this is achieved should any plane be considered ready for flight.

Range Test Your Radio

Before each flying session, be sure to range check your radio. See your radio manual for the recommended range and instructions for your radio system. Each radio manufacturer specifies different procedures for their radio systems. If using a gasoline engine, check the range first with the engine not running and note the distance. Next, start the engine. With the model securely anchored, check the range again. The range test should not be significantly affected. If it is, don't attempt to fly! Have your radio equipment checked out by the manufacturer.

Instructions for Disposal of WEEE by Users in the European Union

This product must not be disposed of with other waste. Instead, it is the user's responsibility to dispose of their waste equipment by handing it over to a designated collection point for the recycling of waste electrical and electronic equipment. The separate collection and recycling of your waste equipment at the time of disposal will help to conserve natural resources and ensure that it is recycled in a manner that protects human health and the environment. For more information about where you can drop off your waste equipment for recycling, please contact your local city office, your household waste disposal service or where you purchased the product.



2007 Official AMA National Model Aircraft Safety Code

GENERAL

1. A model aircraft shall be defined as a non-human-carrying device capable of sustained flight in the atmosphere. It shall not exceed limitations established in this code and is intended to be used exclusively for recreational or competition activity.
2. The maximum takeoff weight of a model aircraft, including fuel, is 55 pounds, except for those flown under the AMA Experimental Aircraft Rules.
3. I will abide by this Safety Code and all rules established for the flying site I use. I will not willfully fly my model aircraft in a reckless and/or dangerous manner.
4. I will not fly my model aircraft in sanctioned events, air shows, or model demonstrations until it has been proven airworthy.
5. I will not fly my model aircraft higher than approximately 400 feet above ground level, when within three (3) miles of an airport without notifying the airport operator. I will yield the right-of-way and avoid flying in the proximity of full-scale aircraft, utilizing a spotter when appropriate.
6. I will not fly my model aircraft unless it is identified with my name and address, or AMA number, inside or affixed to the outside of the model aircraft. This does not apply to model aircraft flown indoors.
7. I will not operate model aircraft with metal-blade propellers or with gaseous boosts (other than air), nor will I operate model aircraft with fuels containing tetranitromethane or hydrazine.
8. I will not operate model aircraft carrying pyrotechnic devices which explode burn, or propel a projectile of any kind. Exceptions include Free Flight fuses or devices that burn producing smoke and are securely attached to the model aircraft during flight. Rocket motors up to a G-series size may be used, provided they remain firmly attached to the model aircraft during flight. Model rockets may be flown in accordance with the National Model Rocketry Safety Code; however, they may not be launched from model aircraft. Officially designated AMA Air Show Teams (AST) are authorized to use devices and practices as defined within the Air Show Advisory Committee Document.
9. I will not operate my model aircraft while under the influence of alcohol or within eight (8) hours of having consumed alcohol.
10. I will not operate my model aircraft while using any drug which could adversely affect my ability to safely control my model aircraft.
11. Children under six (6) years old are only allowed on a flightline or in a flight area as a pilot or while under flight instruction.
12. When and where required by rule, helmets must be properly worn and fastened. They must be OSHA, DOT, ANSI, SNELL or NOCSAE approved or comply with comparable standards.

2007 Official AMA National Model Aircraft Safety Code

Radio Control

1. All model flying shall be conducted in a manner to avoid over flight of unprotected people.
2. I will have completed a successful radio equipment ground-range check before the first flight of a new or repaired model aircraft.
3. I will not fly my model aircraft in the presence of spectators until I become a proficient flier, unless I am assisted by an experienced pilot.
4. At all flying sites a line must be established, in front of which all flying takes place. Only personnel associated with flying the model aircraft are allowed at or in front of the line. In the case of airshows demonstrations straight line must be established. An area away from the line must be maintained for spectators. Intentional flying behind the line is prohibited.
5. I will operate my model aircraft using only radio-control frequencies currently allowed by the Federal Communications Commission (FCC). Only individuals properly licensed by the FCC are authorized to operate equipment on Amateur Band frequencies.
6. I will not knowingly operate my model aircraft within three (3) miles of any preexisting flying site without a frequency-management agreement. A frequency-management agreement may be an allocation of frequencies for each site, a day-use agreement between sites, or testing which determines that no interference exists. A frequency-management agreement may exist between two or more AMA chartered clubs, AMA clubs and individual AMA members, or individual AMA members. Frequency-management agreements, including an interference test report if the agreement indicates no interference exists, will be signed by all parties and copies provided to AMA Headquarters.
7. With the exception of events flown under official AMA rules, no powered model may be flown outdoors closer than 25 feet to any individual, except for the pilot and located at the flight line.
8. Under no circumstances may a pilot or other person touch a model aircraft in flight while it is still under power, except to divert it from striking an individual.
9. Radio-controlled night flying is limited to low-performance model aircraft (less than 100 mph). The model aircraft must be equipped with a lighting system which clearly defines the aircraft's attitude and direction at all times.
10. The operator of a radio-controlled model aircraft shall control it during the entire flight, maintaining visual contact without enhancement other than by corrective lenses that are prescribed for the pilot. No model aircraft shall be equipped with devices which allow it to be flown to a selected location which is beyond the visual range of the pilot.



Fly First Class™



© 2007 Horizon Hobby, Inc.
4105 Fieldstone Road
Champaign, Illinois 61822
(877) 504-0233
horizonhobby.com