



Focke-Wulf 190 RTF Instruction Manual



Charge-and-Fly™ Park Flyer

Wingspan: 39.5 in (1000mm)
Length: 33.5 in (850mm)
Weight with Battery: 26 oz (730 g)
Motor: 480 Power with gear box

Speed Control: FET proportional ESC/receiver
FM Radio: 3 proportional channels
Battery: 9-cell 10.8V 1000mAh Ni-MH
Charger: Variable rate DC peak detect (1.8A)

Focke-Wulf 190 Instruction Manual

Congratulations on your purchase of the ParkZone® Focke-Wulf 190. The famous Focke-Wulf 190 was generally regarded as Germany's best fighter of World War II. The FW-190 helped the Germans in their intended conquest of Europe, and brought fear and trepidation to many of the Allied fighter pilots. With the beautifully detailed ParkZone FW-190, you can envision yourself fighting in the skies of Western Europe against the Allied forces and their collection of Mustangs and Spitfires.

Your ParkZone FW-190 RTF purchase includes everything needed to get you in the air—all in one box! You will only need to attach the wing and horizontal tail, and charge the battery pack, prior to taking to the air for your first flight. Everyone at ParkZone is committed to giving you the most enjoyable flight experience you can have. In order to have a safe and successful flight, we ask that you do not fly until you have read these instructions thoroughly.

The ParkZone FW-190 comes with a fully proportional 3-channel FM radio system, with full control of throttle, ailerons, and elevator. If you are not experienced at fly-

ing one of HobbyZone's 3-channel aircraft, or any other 3-channel radio controlled aircraft, we recommend that you do not fly this aircraft. If you still choose to fly, you will need to seek the help of an experienced radio control pilot during your beginning flights. This is especially important if you have not flown a 3-channel airplane with aileron control as one of the channels. Crash damage is not covered under the warranty!

Your ParkZone FW-190 is equipped with the exclusive Mode Change Flight Control™ system. The computer onboard the airplane is programmed with two flight modes, giving you the opportunity to select the mode that's most comfortable for you. Mode A limits the travel of the ailerons and elevator to allow a less-experienced pilot to have an easier time transitioning to flying with pitch control. It also allows experienced flyers to have a smooth and relaxing flight. Mode B allows for full control at all times. This mode, where the control surfaces move at a more extreme throw than when they are in mode A, is for those who are experienced and looking for maximum performance.

Step 1

Setting Up the Transmitter

1. Insert 8 new "AA" batteries (supplied) into the transmitter, observing proper polarity.
2. Turn the switch on and check to make sure the LED is illuminated, which indicates that the batteries have been installed correctly. Once this is confirmed, turn the radio off.
3. You'll need to replace the transmitter "AA" batteries whenever you hear the low-battery alarm (beeping sound) being emitted from the transmitter. To elongate the life of your "AA" batteries, remove them from your transmitter when you are not using it.

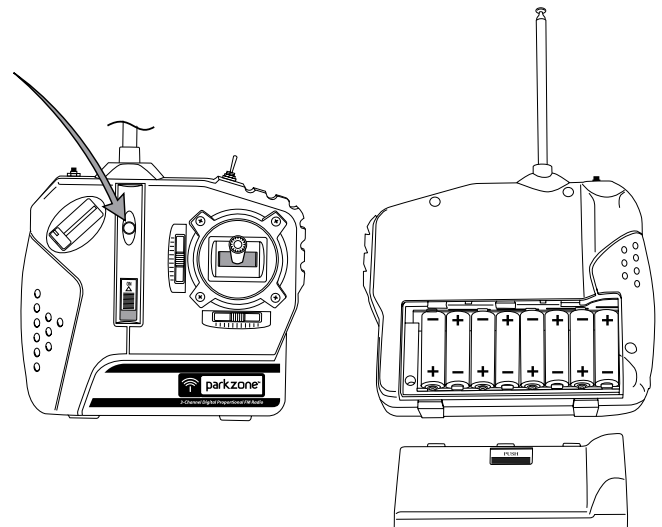

Step 2

Charging the Aircraft Battery

The ParkZone® variable rate DC Peak charger uses unique peak detection circuitry that ensures an accurate charge every time and protects your Ni-Cd and Ni-MH batteries from the dangers of over-charging. This charger continually monitors the battery's charge curve and automatically stops charging when the peak charge is detected. The peak detection charger will help avoid damage to your Ni-Cd and Ni-MH cells.

Important: The battery should be charged shortly before flying. If you charge the battery 12 to 24 hours prior to flying, you will need to “re-peak” the battery before you fly.

WARNING! You cannot charge the optional Li-Po battery packs with the ParkZone variable rate DC Peak charger included with this kit. You must use a Li-Po specific battery charger. Failure to follow this warning could result in a fire.

WARNING! Do not leave the charger or battery unattended during the charge process. While charging, place the battery on a heat resistant surface and constantly monitor the temperature of the battery pack. If the battery becomes hot at any time during the charge process, discontinue charging immediately. It should only be warm to the touch, and should not feel warm until it is almost done charging. Do not allow children to charge battery packs without adult supervision.

Variable Rate DC Peak Detection Charger Features

- Variable charge rate from 0.5–1.8 amps
- Uses automobile 12V power outlet
- Charges 5- to 10-cell Ni-Cd and Ni-MH battery packs
- Trickle charge
- LED charge indicator

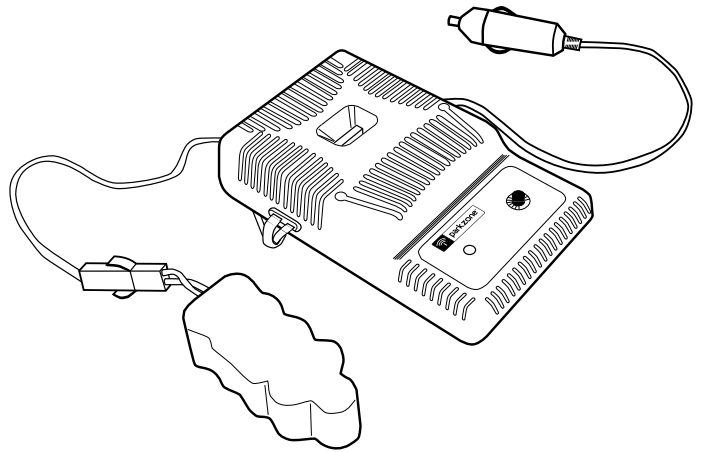

Using Your Variable Rate DC Peak Charger

1. Using the dial on the side of the charger, set the charge rate at 1.4 amps.
2. Connect the battery pack to the charger using the included adapter.
3. Connect the charger to the 12V power outlet in your automobile. The LED will continually blink while the battery charges.
4. Charging is finished when the LED indicator glows steadily. (40 minutes or less)

Note: The charge time is only an estimate of a fully discharged battery pack. Actual charge times may vary. Damage to the charger and battery will occur if you exceed the maximum charge rate recommended.

Step 3

Attaching the Wing

In order to attach the wing of your Focke-Wulf 190, please follow these simple instructions:

1. Locate the included wing screws (in clear plastic bag).
2. Plug in the aileron servo lead from the wing into the aileron extension. This is very important, as the ailerons will be reversed if this is not done.
3. Carefully attach the wing to the fuselage. Use 3 screws to secure the wing as shown.

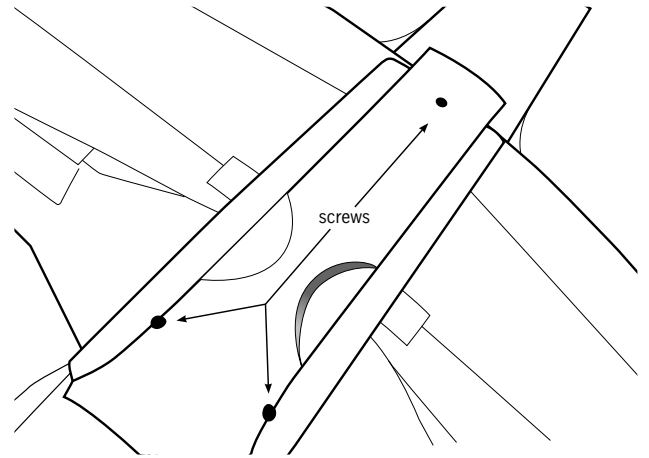

Step 4

Attaching the Horizontal Stabilizer

1. Locate the horizontal stab of the tail.
2. Slide the horizontal tail stab through the allotted space in the fuselage, making sure the control horn attached to the horizontal tail stab will properly align with pushrod and clevis exiting the back of the fuselage.
3. When you are certain the tail is centered correctly, use the provided clear tape to properly secure the tail to the fuselage, as shown. Use the tape

on the top and bottom of each side of the tail (total of 4 applications).

4. Make sure that the throttle slider is all the way down, in the "off" position. Turn on the transmitter and plug in the flight battery. Make sure the trim levers and control stick are centered.
5. Locate where the clevis and rod exit the fuselage, and attach the clevis to control surface as shown.
6. Make necessary trim adjustments prior to flight. See step 5 for instructions on how to do this.

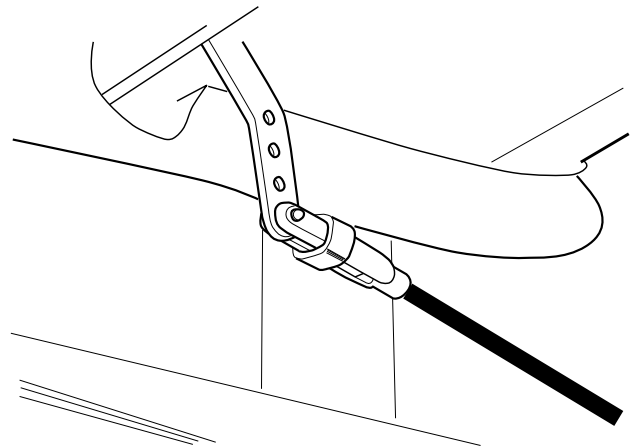
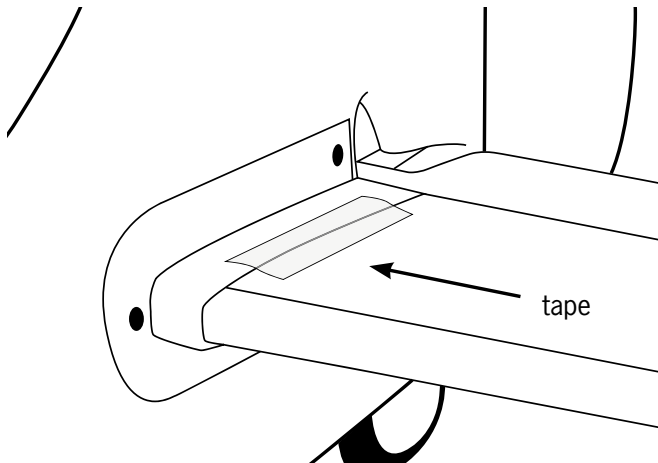

Center of Gravity Information

The center of gravity (CG) of the ParkZone FW 190 is approximately 5 ³/₄" forward from the trailing edge of the wing. You will notice two panel lines at this location and the CG is between those lines. This is for both the stock 9 cell Ni-MH and also a 3S LiPO pack.

You can confirm this by placing your fingers between these panel lines and balancing the plane while it is inverted.

Step 5

Making Trim Adjustments to the Horizontal Stabilizer

1. Turn on transmitter.
2. Install a fully charged battery into the battery compartment and secure it with the included Velcro.
3. Set the elevator trim lever to center.

4. Make certain the elevator is set to neutral with the horizontal stabilizer. Do this by removing the clevis from the control horn and turning it on the pushrod as needed. Once the adjustment is made, reattach the clevis.
5. If you feel more adjustments are necessary while in flight, move the trim lever on the transmitter a

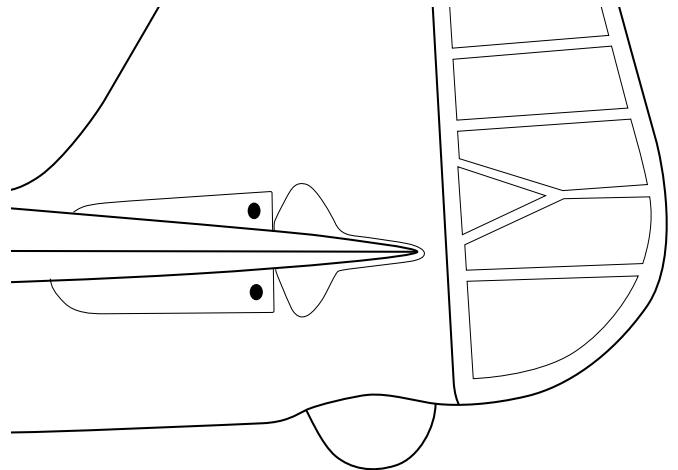
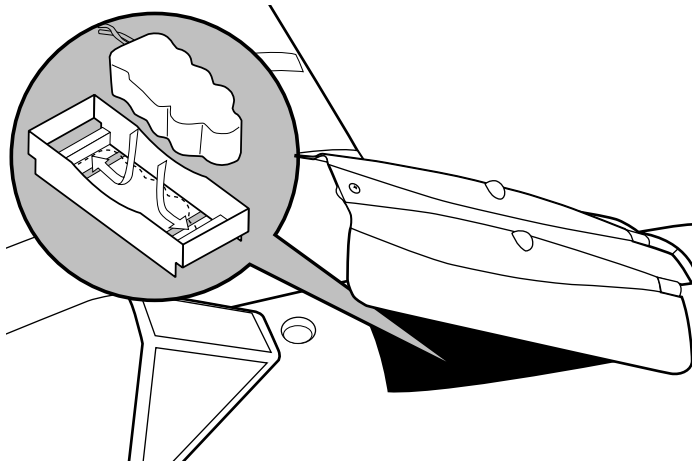

Step 6

few “clicks” up or down as needed.

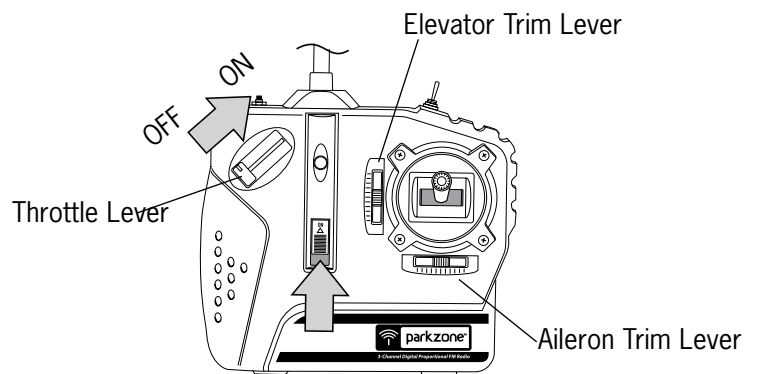

Motor Test

Warning: Keep everything clear of the propeller before starting the motor test so you do not damage any property or harm anyone.

1. Make sure the throttle slider is in the “off” position.
2. Turn on the transmitter.
3. Plug the flight battery into the white lead inside the fuselage.

Step 7

Control Test

Warning: Keep everything clear of the propeller before starting the control test in the event that you accidentally turn on the motor.

1. Be certain that the throttle slider is in the “off” position and that both trim levers are centered.
2. Switch on the transmitter and check to make sure the LED is lit, indicating the transmitter has power.
3. Install the flight battery into the fuselage and plug it into the battery connector.
4. Move the stick from side to side. The ailerons on the trailing edge of the wings should move per your transmitter input. When the stick is pushed to the right, the right aileron should deflect upward and the left aileron downward, and vice versa.
5. Pull the stick back and the elevator control surface should move upward (as shown).
6. Move the stick full forward. When this is done, the elevator control surface should move down (as shown).
7. When the test is complete, be sure to disconnect the flight battery first, and then turn off the transmitter. This should be done each time you turn off the airplane.

Note: It is very important to make sure that the control surfaces are at 0 degrees when the transmitter control stick and trim levers are centered. (See Steps 5 and 8 for making needed adjustments to control surfaces.)

If your airplane is not responding correctly to the transmitter input, do not fly! Some correction is needed. Call the Horizon Product Support line at 1-877-504-0233.

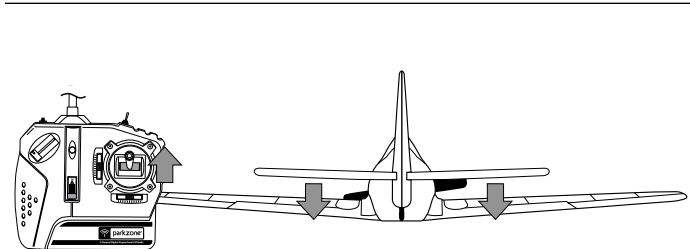
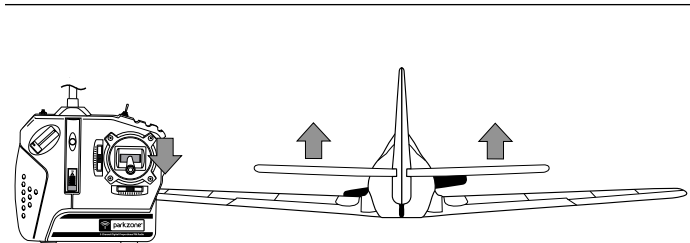
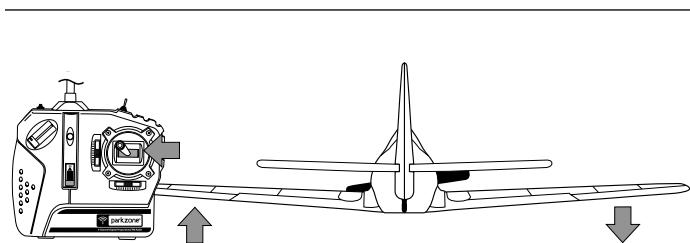
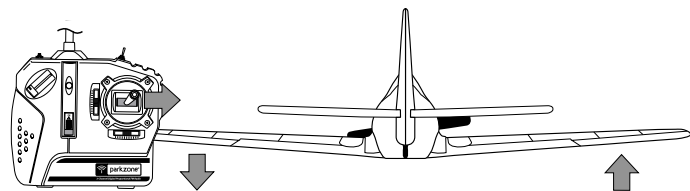

Step 8

Making Adjustments to the Ailerons

Warning: Keep everything clear of the propeller before adjusting the ailerons in the event that you accidentally turn on the motor.

You may find some adjustment is needed to properly trim the ailerons. The ailerons are properly trimmed when each aileron is level with the stationary wing surface. To do this, follow these simple instructions:

1. Make sure the throttle slider is in the “off” position and then turn on the transmitter.
2. Install the flight battery and plug it into the lead from the fuselage.
3. Most trim adjustments to the ailerons can be made with the aileron trim levers on the transmitter. Make sure the gimbal (stick) is at neutral prior to making any trim changes.

Step 8

4. If trimming the ailerons with the trim levers is not sufficient, and the ailerons need to be trimmed mechanically, you'll need to do the following:
 - a. With the radio system on, return the trim levers and gimbal to their neutral positions.
 - b. Locate the small thumbscrew on each aileron (bottom of the control surface).
 - c. Loosen the thumbscrew until the pushrod is free from the control horn and move the aileron control surface to the neutral position.
 - d. Hold the aileron at neutral with one hand while retightening the thumbscrew on the control horn so that the control surface will then be held at neutral when the trim levers and gimbal are in the neutral position.

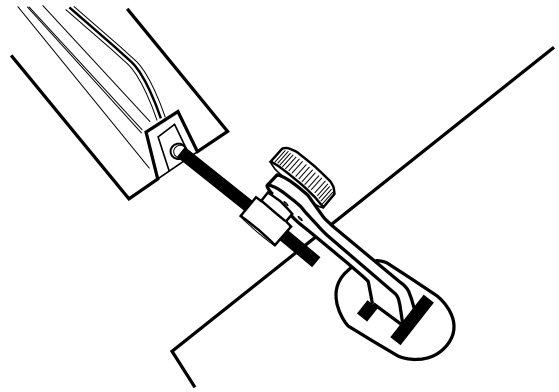

If you have any questions about making these adjustments, please contact Horizon Product Support at 1-877-504-0233.

Step 9

Choosing a Flying Field

- A large, open grassy field is required to fly your ParkZone® Focke-Wulf 190. Your FW-190 can achieve speeds greater than 40 mph, so it covers ground fast. The larger the field you choose, the better off you will be!
- It is essential to have a minimum of 300 feet of clear space in all directions from the pilot. If you ignore this direction, you will regret it.
- Make certain that you do not fly near trees, buildings, or other areas that can restrict your view or interfere with your flying. NEVER fly near streets, parking lots, or people.

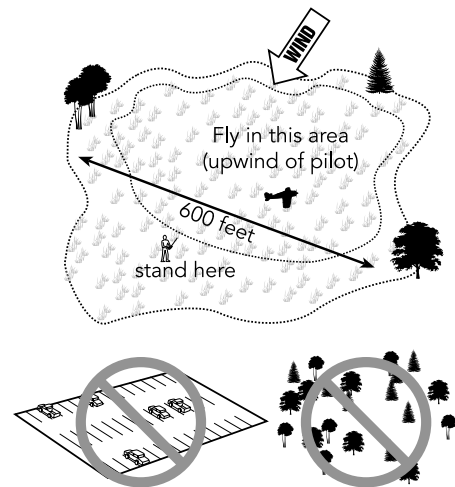

Step 10

Optimal Flying Conditions

You want to fly! However, you need to make sure that you fly in the conditions that will allow you to have the best success. This is when there is little to no wind (less than 8 mph or nearly 13 km/h).

To check wind conditions:

1. Tie the included red ribbon to the transmitter antenna.
2. Hold the transmitter antenna so it is parallel to the ground and note how much the ribbon moves in the wind. If the ribbon hangs down, conditions are perfect to fly. There is some variance in the amount of wind that you can fly in, but if the

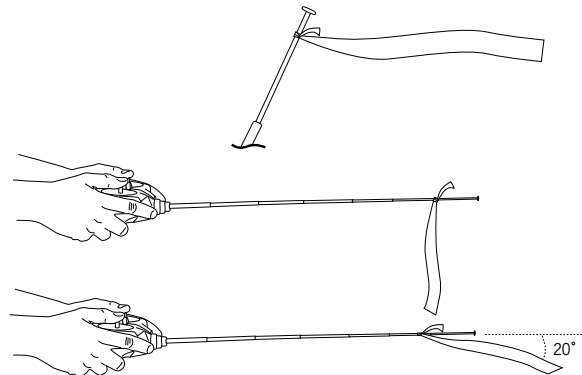

angle between the antenna and the ribbon, when the antenna is parallel to the ground, is less than 20 degrees, it is too windy to fly.

Step 11

Range Test

You will need two people to perform the range test—one to hold the plane and the other to give the transmitter input.

Warning: The person holding the plane should hold it in such a way that the propeller does not come into contact with any part of their clothing or body.

1. One person should hold the transmitter, while the other person walks 100 paces away from the transmitter, with the airplane in hand.
2. Be sure the throttle slider is in the “off” position.
3. Extend the transmitter antenna completely and turn the transmitter on.
4. Slide the battery into the fuselage, attach it to the lead from the fuselage and close the canopy.

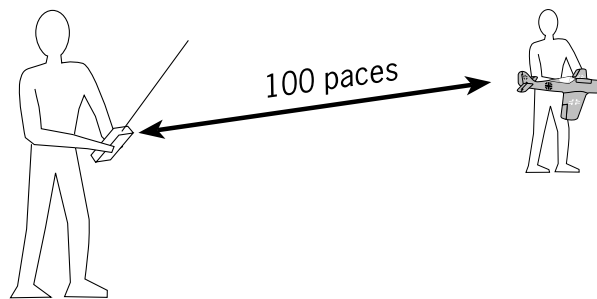

5. Advance the throttle. When the throttle slider is advanced, the propeller should spin quickly.
6. As the first person moves the transmitter controls, the other person watches to be sure the airplane’s motor and tail controls operate smoothly. Make sure you check all parts of the controls—throttle, as well as moving the gimbal up and down, and side to side.

Step 12

First Flights

The ParkZone® 3-channel control system is designed for the experienced radio control pilot and is not intended for the first-time flyer. If you have successfully flown 3-channel HobbyZone® airplanes, then you should be ready for the ParkZone FW-190. However, first-time pilots of the ParkZone FW-190 should seek the assistance of an experienced RC flyer until the additional third channel, pitch control, has been competently mastered. If you do not have experience with controlling the ailerons, it will be very helpful to have an experienced pilot with you when you first start to fly. Crash damage is not covered under the warranty.

Important: Initial flights should always be done with the airplane in Low Rate (Mode A). In this mode, there is some limitation to the travel of the control surfaces, helping to prevent you from over-control. After you have had several safe flights in Mode A, you can move on to Mode B, which will no longer limit the travel of the control surfaces.

Note: It is possible to change flight modes while the plane is in flight. However, it is important that you have enough altitude while in flight prior to attempting to change the flight mode.

Step 13

Mode Change Flight Control System

Your FW-190 comes with the ability to change flight modes as you gain more experience and become more familiar with it. There are two modes, selectable from the transmitter, from which you can choose:

Mode A (Low Rate) - Mode A is recommended for all first flights. The travel of both ailerons, as well as the elevator, will be limited in this mode, allowing you to become more familiar with your plane. The switch on top of the transmitter will be back when you are in this mode.

Mode B (High Rate) - Mode B no longer limits your control surface travel, allowing more aggressive flying and aerobatics. However, your FW-190 will also be more prone to crashes due to over-control if you are not careful. The switch on the transmitter will be toward the pilot when in this mode.

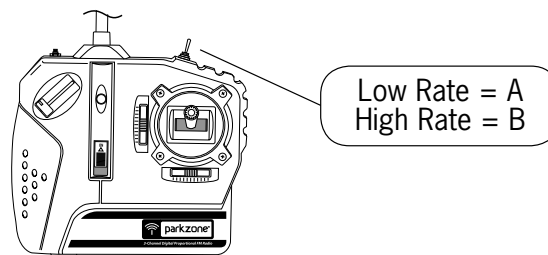

Step 14

Receiver/ESC

Your ParkZone® FW-190 comes with a specially designed receiver/ESC unit that allows you great flexibility for its use. There are three jumpers that are located in the receiver that can be changed (added/removed) that allow you to make changes, if you choose, from the stock configuration that comes in your aircraft. You can also reuse the included radio system in another ParkZone or other similar electric aircraft due to the adaptability of the receiver/ESC included.

Jumper 1 (Mix of Elevator and Aileron)

You can add the jumper to utilize the software that will allow a slight mix of elevator and ailerons. In this mode, when aileron input is given, a slight amount of up elevator is added. By doing this, the nose of the airplane will be more likely to stay up when aileron input is given. This setup is not recommended for the FW-190.

Jumper 2 (V-Tail/Standard Tail)

Your FW-190 comes with the plane set for conventional aileron control. If you remove the included jumper, you can change the radio system to function for “V” tail (elevon) control in the event you want to transfer the equipment to other planes,

such as the ParkZone F-27B Stryker™ or Slo-V™.

Jumper 3 (Auto Cutoff)

Your FW-190 comes with the ability to change the cutoff voltage of the radio system. When the jumper is present the auto-cut is set at about 5.7 volts, which works with 6- to 9-cell Ni-MH battery packs. When the jumper is absent, the auto cut is set at about 8.8 volts, which will function correctly with a 3S Li-Po Battery.

Note: Your ParkZone FW-190 is designed to support a 3S Li-Po battery. We recommend the Thunder Power 2100mAh pack (THP21003SPL). You will need to supply your own connectors. The battery should be able to safely deliver 13 amps of current.

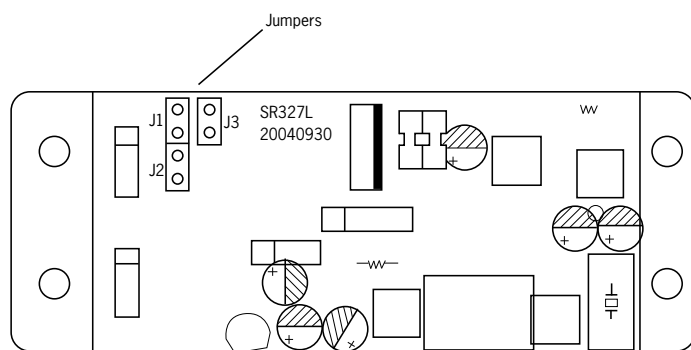

The default positions of the jumpers on your Focke-Wulf 190 receiver are shown below in bold italics.

	JUMPER PRESENT	JUMPER ABSENT
Jumper 1	Flight-Trak™ On*	<i>Flight-Trak Off</i>
Jumper 2	<i>Conventional Control</i>	“V” tail/Elevon control
Jumper 3	<i>6–9 cell Ni-MH</i>	3S Li-Po

*Flight-Trak gives some up elevator when directional input is given.

Step 15

Hand Launching the FW-190

Your ParkZone® FW-190 will need to be hand launched. To do this, follow these instructions:

1. Make certain that the aircraft battery is fully charged. If it has been longer than 12 hours since you fully charged your Ni-MH battery, you'll want to peak it again with your variable rate DC peak charger. See Step 2 for battery charging. If you're using a Li-Po battery, please follow the charging directions for your Li-Po compatible charger.
2. Turn on the transmitter, making certain you are in Mode A (Low Rate).
3. Insert the battery into the fuselage and plug the battery lead into the lead coming from the fuselage. Secure the battery with the Velcro straps
4. While holding the transmitter in one hand, push throttle slider to full on (up) with thumb.
5. Take a couple of steps and **FIRMLY** launch directly into the wind while keeping the wings level. Do not

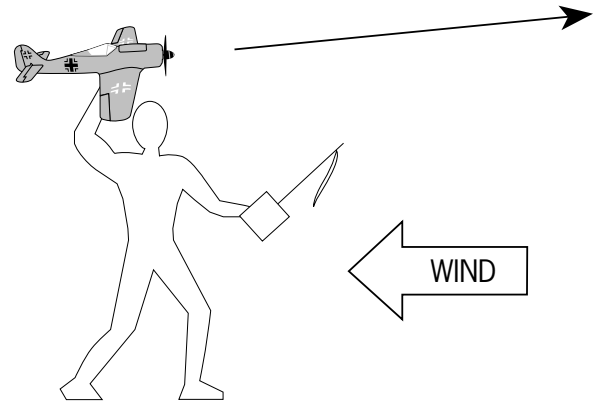

throw it up or down. Point it level (parallel) with the ground when releasing.

6. Keep steering into the wind and hold at full throttle in a slight climb until you have reached an altitude of at least 50 to 70 feet (15 to 21 meters).
7. When you have reached this altitude, it is safe to steer in the desired direction, as well as adjust the throttle input, to help control altitude and speed.

Step 16

Helpful Hints for Flight:

1. After launching, your FW-190 will climb at full throttle. Keep the throttle full on until you have reached an altitude of at least 50 feet (15 meters). At the same time, make sure that you continue to keep the airplane flying directly into the wind.
2. Make right and left adjustments, as necessary, to keep the plane headed directly into the wind. After you have reached approximately 100 feet (30 meters) of altitude, you can begin to make directional changes that you desire.
3. Remember—control range is 2,500 feet (762 meters). Do not allow the plane to get too far away from you. When the plane is farther away it is harder to see, and the higher you fly, the more the airplane will be affected by wind.
4. Always keep the plane upwind from you. This way, it will not be carried away from you by the wind.
5. Flying in winds that are too strong is by far the number one reason for those who are less experienced to crash or have fly-aways.
6. Avoid holding the stick full right or left for more than two seconds, as this will cause the plane to enter a spiral dive that could cause you to crash your plane.

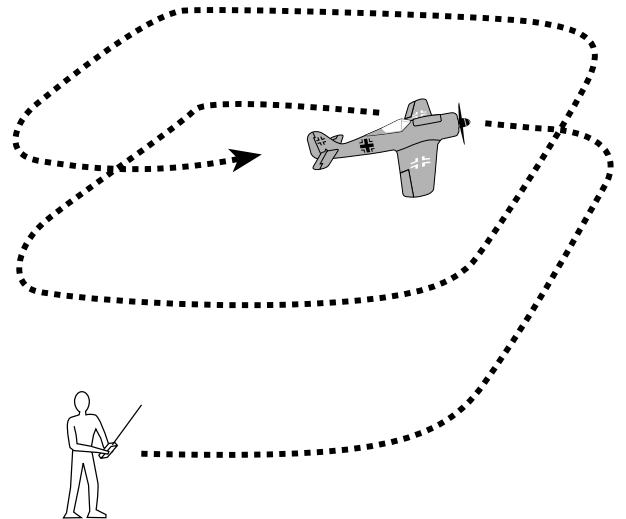

7. Do not try to climb too fast by pulling all the way back on the stick (up elevator), or your plane may stall. Instead, climb by giving small amounts of elevator.
8. Damage/bends to the wings or tail can greatly affect flight control. Replace damaged parts immediately.
9. Once you have become more experienced and familiar with the FW-190, you can switch from Mode A to Mode B. Mode B no longer limits the travel of the control surfaces.

Step 17

Throttle Adjustment:

1. Climb to a minimum altitude of 50 to 70 feet (15 to 21 meters) at full throttle.
2. To achieve and maintain a level “cruising” altitude, reduce the power by moving the throttle slider down to approximately 70% of full on. The

3. To reduce altitude, reduce the throttle, and to increase altitude, increase the throttle.

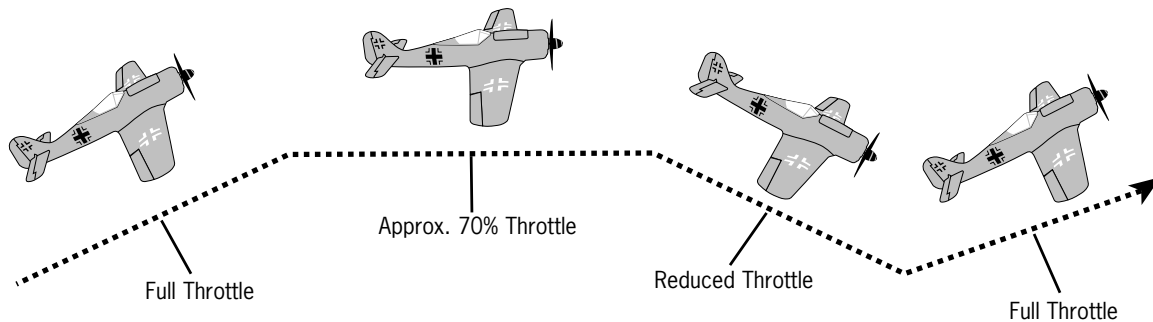

Step 18

Using Elevator:

Your ParkZone® FW-190 is equipped with a third channel for elevator (pitch control). Pulling back on the stick provides up elevator. Pulling too far back on the elevator to climb too quickly will cause the airplane to enter a stall (make the nose of the plane come down). To avoid crashing from a stall, always maintain enough altitude to recover. Just after a stall has occurred, the nose of the airplane will fall and the plane will look like it is diving. To pull

out of a stall, simply pull back slowly on the stick (partial up elevator) once your FW-190 has built up airspeed as it decreases in altitude. Remember, pulling back too quickly or for too long will once again cause the airplane to enter a stall. Effectively avoiding and recovering from stalls requires experience. Always seek the help of an experienced radio control pilot if you are not familiar with pitch control. Failure to do this could result in a crash and significant damage to your airplane.

Step 19

Landing Your FW-190

When you begin to notice that your FW-190 no longer climbs well under full power (normally after approximately 10–12 minutes), the battery is getting low and it is time to land. Bring your aircraft directly into the wind and toward the desired landing spot. Gradually reduce throttle (and give a small amount of down elevator if you choose) to reach an altitude of approximately 10 feet (3 meters). At this point, reduce the throttle even more until it is eventually at no throttle and your FW-190 should glide in softly for a landing. To avoid damage to your aircraft, land on a smooth soft surface, such as grass.

Expert Tip: As you get better and more experienced at flying, try adding a bit of “up” elevator just prior to landing to “flare” the plane.

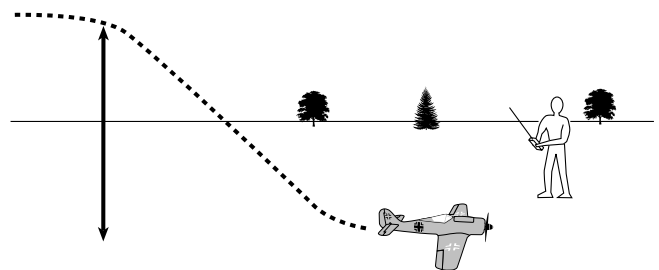

With some practice, your landings should become smooth and on target.

WARNING: Do not attempt to catch the airplane or injury may occur. Remember, there is a spinning propeller on the front of the plane that can cause injury! Also, remember to cut power to the motor right before landing to prevent damage to the propeller.

Step 20

Aerobatic Flight

Your FW-190 comes out of the box with the controls set for softer responses and with the clevis attached to the outer holes of control horns on the control surfaces. However, once you get used to the flight characteristics and want to perform more aerobatic maneuvers, you can change the amount of throw that is permitted by moving the clevises to the inner holes of the control horns and switching

to Mode B. After making any adjustments, always turn on the transmitter and center the transmitter trim levers, making sure the control surfaces are adjusted evenly. If they are not even, refer to Steps 5 and 8 for trimming the control surfaces.

Note: *By making these changes, the controls will be much more responsive. This makes the airplane much less forgiving and easier to stall. Remember, crash damage is not covered under the warranty.*

Step 21

Repairing Minor Damage

If you happen to crash, and part of the tail or wing breaks, you can repair the damage by using packing tape to cover the missing pieces. However, if the damage is severe, or if the wings and/or tail are bent, replace the damaged parts prior to flying again. See the last few pages of the manual for a complete list of replacement parts for your FW-190.

Warnings and Safety

1. Read and follow this manual completely, observing all instructions and safety directions. Otherwise, serious injury and damage can occur. Think about your safety, and the safety of others, first.
2. Keep the propeller away from body parts and clothing, even when it isn't spinning, as it could be turned on by accident. Beware of hair becoming entangled in the propeller, especially while launching your plane.
3. Do not fly when it's too windy or you may lose control and crash, causing injury or damage. Never fly near people, vehicles, train tracks, buildings, power lines, water, hard surfaces or trees. Never allow anyone to attempt to catch the airplane while it's in flight or serious injury may result.
4. Adult supervision for flying and battery charging is recommended for pilots age 14 and younger.
5. Only use a battery charger that is Ni-MH compatible to charge the flight battery. Never leave the charger unattended while charging. This will help prevent overcharging and make sure damage does not occur to the battery, charger or any other property. While charging, place the battery on a heat resistant surface. Do not lay it on carpet or upholstery while charging. If you are using a Li-Po battery to fly your FW-190, you will need to use a Li-Po compatible charger for that battery pack.
6. Never cut into the battery, charger, or airplane wires or serious injury may occur. Causing the battery to "short out" (crossing negative and positive bare wires) can cause fire, serious injury and damage.
7. Hold the plane securely when the flight battery is plugged in, and keep all body parts away from the propeller. When you finish flying your airplane, always unplug the battery before you turn off the transmitter.
8. Never fly on the same frequency as another RC vehicle in your area. The frequency of the airplane is shown on stickers on the back of the transmitter and on the airplane.
9. If you decide to power your FW-190 with a Li-Po battery, follow the instructions and warnings included with the battery and charger. ALWAYS unplug and remove your battery after flying.

Success Tips

1. Don't fly in winds over 10 mph! If you are a less experienced pilot, this is especially important.
2. A pilot who has never flown a 3-channel plane with pitch control should get help from an experienced radio control pilot during first flights. Pilots who have not flown a 3-channel plane at all should not fly unless an experienced RC pilot is present to guide them.
3. Choose your flying field carefully—grass and soft ground with a 600-foot (183-meter) diameter of open space is optimal for flying and will lengthen the life of your airplane. Make sure there are no obstacles that will get in your way when flying, such as trees or buildings. Make sure you do not fly where there are pedestrians who could be hurt by the airplane.
4. Remember that holding the stick full over for too long can cause the airplane to spiral dive and crash. At the very first sign of the plane beginning to spiral down, immediately release the stick and give the opposite turn control to the spiral, then pull back on the elevator gently to level flight and level the wings.
5. Don't attempt to fly or do maneuvers beyond your flying abilities. Seek the assistance of an experienced pilot when trying new maneuvers that are more extreme and involve fast flight.
6. If you're gliding with the motor off, allow your plane more area for turns.
7. Position yourself at your flying field so that you keep the sun at your back and out of your eyes. Wear sunglasses on bright days.
8. Keep the aircraft upwind, especially on windier days, to prevent it from "flying away." The wind is normally stronger at higher altitudes than it is on the ground.
9. Keep your plane in front of you so you don't have to turn in circles as you fly. Try to avoid flying directly overhead.

Troubleshooting

PROBLEM	POSSIBLE CAUSE	SOLUTION
Unit does not operate.	<ol style="list-style-type: none"> 1. Transmitter "AA" batteries are depleted or installed incorrectly, indicated by a dim or unlit LED on transmitter or the low battery alarm. 2. No electrical connection. 3. Flight battery not charged. 4. Crash has damaged the radio inside. 	<ol style="list-style-type: none"> 1. Check polarity installation or replace with fresh "AA" batteries. 2. Push connectors together until they "click." 3. Charge battery fully. 4. Replace the fuselage or receiver.
Aircraft keeps turning in one direction	<ol style="list-style-type: none"> 1. Aileron or aileron trim is not adjusted correctly. 2. Damage to fixed rudder (vertical stab). 	<ol style="list-style-type: none"> 1. Adjust aileron and/or aileron trim. 2. Make sure fixed rudder (vertical stab) is at 90 degrees from elevator.
Aircraft is difficult to control	<ol style="list-style-type: none"> 1. Wing or tail is damaged. 	<ol style="list-style-type: none"> 1. Replace damaged part.
Aircraft will not climb	<ol style="list-style-type: none"> 1. Battery is not fully charged. 2. Elevator trim may be incorrect. 	<ol style="list-style-type: none"> 1. Charge battery fully shortly before flying. 2. Adjust elevator trim.
Aircraft keeps pitching up steeply	<ol style="list-style-type: none"> 1. Wind is too gusty or strong. 2. Elevator trim may have raised too much. 	<ol style="list-style-type: none"> 1. Postpone flying until the wind calms down. 2. Trim elevator down with the transmitter trim or threaded linkage.

Warranty and Follow-Up Procedures

Limited Warranty Period

Horizon Hobby, Inc. guarantees this product to be free from defects in both material and workmanship at the date of purchase.

Limited Warranty & Limits of Liability

Pursuant to this Limited Warranty, Horizon Hobby, Inc. will, at its option, (i) repair or (ii) replace, any product determined by Horizon Hobby, Inc. to be defective. In the event of a defect, these are your exclusive remedies.

This warranty does not cover cosmetic damage or damage due to acts of God, accident, misuse, abuse, negligence, commercial use, or modification of, or to any part of the Product. This warranty does not cover damage due to improper installation, operation, maintenance, or attempted repair by anyone other than an authorized Horizon Hobby, Inc. service center. This warranty is limited to the original purchaser and is not transferable. In no case shall Horizon Hobby's liability exceed the original cost of the purchased product and will not cover consequential, incidental or collateral damage. Horizon Hobby, Inc. reserves the right to inspect any and all equipment involved in a warranty claim. Repair or replacement decisions are at the sole discretion of Horizon Hobby, Inc. Further, Horizon Hobby reserves the right to change or modify this warranty without notice.

This warranty covers only those products purchased from an authorized Horizon Hobby dealer. Third party transactions are not covered by this warranty. Proof of purchase is required for warranty claims.

REPAIR OR REPLACEMENT AS PROVIDED UNDER THIS WARRANTY IS THE EXCLUSIVE REMEDY OF THE CONSUMER. HORIZON HOBBY, INC. SHALL NOT BE LIABLE FOR ANY INCIDENTAL OR CONSEQUENTIAL DAMAGES.

As Horizon Hobby, Inc. has no control over use, setup, final assembly, modification or misuse, no liability shall be assumed nor accepted for any resulting damage or injury. By the act of use, setup or assembly, the user accepts all resulting liability. If you as the purchaser or user are not prepared to accept the liability associated with the use of this product, you are advised to return this product immediately in new and unused condition to the place of purchase.

Safety Precautions

This is a sophisticated hobby product and not a toy. It must be operated with caution and common sense and requires some basic mechanical ability. Failure to operate this product in a safe and responsible manner could result in injury or damage to the product or other property. This product is not intended for use by children without direct adult supervision. The product manual contains instructions for safety, operation and maintenance. It is essential to read and follow all the instructions and warnings in the manual, prior to assembly, setup or use, in order to operate correctly and avoid damage or injury.

Questions, Assistance, and Repairs

Your local hobby store and/or place of purchase cannot provide warranty support or repair. Once assembly, setup or use of the product has been started, you must contact Horizon Hobby, Inc. directly. This will enable Horizon to better answer your questions and service you in the event that you may need any assistance.

Questions or Assistance

For questions or assistance, please direct your email to productsupport@horizonhobby.com, or call 877.504.0233 toll free to speak to a service technician.

Inspection or Repairs

If your product needs to be inspected or repaired, please call for a Return Merchandise Authorization (RMA). Pack the product securely using a shipping carton. Please note that original boxes may be included, but are not designed to withstand the rigors of shipping without additional protection. Ship via a carrier that provides tracking and insurance for lost or damaged parcels, as Horizon Hobby, Inc. is not responsible for merchandise until it arrives and is accepted at our facility. Include your complete name, address, phone number where you can be reached during business days, RMA number, and a brief summary of the problem. Be sure your name, address, and RMA number are clearly written on the shipping carton.

Warranty Inspection and Repairs

To receive warranty service, you must include your original sales receipt verifying the proof-of-purchase date. Providing warranty conditions have been met, your product will be repaired or replaced free of charge. Repair or replacement decisions are at the sole discretion of Horizon Hobby.

Non-Warranty Repairs

Should your repair not be covered by warranty and the expense exceeds 50% of the retail purchase cost, you will be provided with an estimate advising you of your options. You will be billed for any return freight for non-warranty repairs. Please advise us of your preferred method of payment. Horizon Hobby accepts money orders and cashiers checks, as well as Visa, MasterCard, American Express, and Discover cards. If you choose to pay by credit card, please include your credit card number and expiration date. Any repair left unpaid or unclaimed after 90 days will be considered abandoned and will be disposed of accordingly.

Electronics and engines requiring inspection or repair should be shipped to the following address (freight prepaid):

Horizon Service Center
4105 Fieldstone Road
Champaign, Illinois 61822

All other products requiring inspection or repair should be shipped to the following address (freight prepaid):

Horizon Product Support
4105 Fieldstone Road
Champaign, Illinois 61822 .

Replacement Parts

Make sure that you keep your FW-190 in the air. Replacement parts are available at your local hobby shop or from Horizon Hobby (www.horizonhobby.com). Please try your local retailer first. By supporting your local hobby shop, they will be there when you need them!

ITEM #	DESCRIPTION	RETAIL
PKZ1600	Focke Wulf 190 RTF Electric	\$229.99
PKZ1602	Decal Sheet: FW-190	\$4.99
PKZ1603	Painted Pilot: FW-190	\$5.49
PKZ1607	Spinner: FW-190	\$3.49
PKZ1608	Threaded Nose Weight (18g): FW-190	\$.99
PKZ1612	Battery Hatch: FW-190	\$1.99
PKZ1613	Clear Canopy: FW-190	\$3.49
PKZ1614	Internal Structure: FW-190	\$1.99
PKZ1615	Instruction Manual: FW-190	\$0.99
PKZ1620	Painted Wing (No Servo): FW-190	\$37.99
PKZ1622	Pushrod with Clevis: FW-190	\$2.59
PKZ1624	Horizontal Stabilizer: FW-190	\$12.99
PKZ1626	Painted Cowl: FW-190	\$5.99
PKZ1628	Complete Gearbox: FW-190	\$8.99
PKZ1661	Fuselage with Electronics: CH1: FW-190	\$72.99
PKZ1662	Fuselage with Electronics: CH2: FW-190	\$72.99
PKZ1663	Fuselage with Electronics: CH3: FW-190	\$72.99
PKZ1664	Fuselage with Electronics: CH4: FW-190	\$72.99
PKZ1665	Fuselage with Electronics: CH5: FW-190	\$72.99
PKZ1666	Fuselage with Electronics: CH6: FW-190	\$72.99
PKZ1667	Painted Bare Fuselage: FW-190	\$29.99
PKZ1670	Replacement Air Frame: FW-190	\$139.99
PKZ1005	Propeller: P-51D, FW-190	\$3.49
PKZ1027	10.8V 1000mAh Ni-MH Battery: P-51D, 3D, FW-190	\$32.99
PKZ1130	Mini Servo (5W) with Arms: ParkZone	\$9.99
PKZ1131	Gear Set with Accessories (5W Servo)	\$2.49
PKZ1132	Servo Arm Assortment (3W & 5W)	\$1.59
PKZ1241	Tx: CH1, 26.995: F27/B, SloV, DECN, P-51D, FW-190	\$32.99
PKZ1242	Tx: CH2, 27.045: F27/B, SloV, DECN, P-51D, FW-190	\$32.99
PKZ1243	Tx: CH3, 27.095: F27/B, SloV, DECN, P-51D, FW-190	\$32.99
PKZ1244	Tx: CH4, 27.145: F27/B, SloV, DECN, P-51D, FW-190	\$32.99
PKZ1245	Tx: CH5, 27.195: F27/B, SloV, DECN, P-51D, FW-190	\$32.99
PKZ1246	Tx: CH6, 27.255: F27/B, SloV, DECN, P-51D, FW-190	\$32.99
PKZ1504	Prop Shaft with Hardware: P-51D, FW-190	\$2.49
PKZ1509	X-Port Extension	\$1.99
PKZ1519	5- to 10-Cell DC Peak Charger (1.8 amps)	\$29.99
PKZ1521	Control Horns (3) with Wing Skids: P-51, FW-190	\$1.29
PKZ1529	Aileron Extension (Reversing)	\$1.99
PKZ1534	Motor with Pinion: P-51D, FW-190	\$10.99
PKZ1535	Pinion (2): P-51D, FW-190	\$1.99
PKZ1536	Motor Screws (2): P-51D, FW-190 (M2.5x6)	\$.99
PKZ1551	Rx (SR-327LT): CH1, 26.995: P-51D, F27B, FW-190	\$28.99
PKZ1552	Rx (SR-327LT): CH2, 27.045: P-51D, F27B, FW-190	\$28.99
PKZ1553	Rx (SR-327LT): CH3, 27.095: P-51D, F27B, FW-190	\$28.99
PKZ1554	Rx (SR-327LT): CH4, 27.145: P-51D, F27B, FW-190	\$28.99
PKZ1555	Rx (SR-327LT): CH5, 27.195: P-51D, F27B, FW-190	\$28.99
PKZ1556	Rx (SR-327LT): CH6, 27.255: P-51D, F27B, FW-190	\$28.99

OPTIONAL PARTS AND ACCESSORIES

HBZ1081	Charger Pigtail	\$1.00
HBZ1083	Large Battery Connector: 900mAh	\$.79
THP21003SPL	Thunder Power 2100mAh 3-Cell 11.1V Li-Po Battery	\$84.95
EFLC3005	Celectra 1-3 Cell Li-Po DC Charger	\$53.99
HBZ4020	Sonic Combat Module with X-Port Technology	\$23.99

X-Port Accessories

Your Focke-Wulf 190 comes equipped with the ability to add to the excitement of flying. X-Port™ technology, exclusive to HobbyZone® and ParkZone® planes, allows for such things as air-to-air combat, dropping bombs, and even night flight for select aircraft. These items (sold separately) instantly add fun and challenge to your flights.

For the Focke-Wulf 190, we recommend you use the Sonic Combat Module™ (HBZ4020). You can take on other X-Port equipped aircraft by attaching this module to your plane and shooting down your buddy's airplane.

When you “hit” another airplane, a high-pitched sound can be heard that signals you have hit that plane, leaving the motor of the “hit” plane disabled for about 8 seconds. The pilot will still maintain the ability to steer for a safe landing or reposition their plane for a counterattack.

We do not recommend you use the Aerial Drop Module™ (HBZ6023) or Night Flight Module™ (HBZ3510) with your Focke-Wulf 190. Please visit www.parkzone.com for information about new X-Port modules.

Future RC Flight

We hope you enjoy flying your new Focke-Wulf 190, and thank you for supporting ParkZone®. Please continue to watch ParkZone.com for the most up-to-date information. This is the official website of the creators and distributors of all ParkZone products. There are many other planes available from ParkZone in a variety of models, from scale civilian aircraft to warbirds to planes that can be flown indoors and out, and we're always working on new and exciting products for you.

For more advanced electric products beyond ParkZone, we recommend that you research the items developed and distributed under the E-flite™ brand. Visit HorizonHobby.com for more information.

Sincerely,
The ParkZone Team

PKZ1615



ParkZone® products are distributed exclusively by
Horizon Hobby, Inc.
4105 Fieldstone Road
Champaign, IL 61822
© 2006 Horizon Hobby, Inc.
www.parkzone.com



parkzone™