



# *Serenity*<sup>™</sup>

**1-Meter  
Sailing Yacht  
Owners Manual**

**PRO BOAT**

## Notice

All instructions, warranties and other collateral documents are subject to change at the sole discretion of Horizon Hobby, Inc. For up-to-date product literature, visit <http://www.horizonhobby.com> and click on the support tab for this product.

## Meaning of Special Language

The following terms are used throughout the product literature to indicate various levels of potential harm when operating this product:

**NOTICE**: Procedures, which if not properly followed, create a possibility of physical property damage AND a little or no possibility of injury.

**CAUTION**: Procedures, which if not properly followed, create the probability of physical property damage AND a possibility of serious injury.

**WARNING**: Procedures, which if not properly followed, create the probability of property damage, collateral damage, and serious injury OR create a high probability of superficial injury.

 **WARNING**: Read the ENTIRE instruction manual to become familiar with the features of the product before operating. Failure to operate the product correctly can result in damage to the product, personal property and cause serious injury.

This is a sophisticated hobby product and NOT a toy. It must be operated with caution and common sense and requires some basic mechanical ability. Failure to operate this Product in a safe and responsible manner could result in injury or damage to the product or other property. This product is not intended for use by children without direct adult supervision. Do not attempt disassembly, use with incompatible components or augment product in any way without the approval of Horizon Hobby, Inc. This manual contains instructions for safety, operation and maintenance. It is essential to read and follow all the instructions and warnings in the manual, prior to assembly, setup or use, in order to operate correctly and avoid damage or serious injury.

## Specifications

Length .....	36.50 in (927.1mm)
Beam.....	9.0 in (228.6mm)
Height.....	63.0 in (1600mm)
Rudder Servo.....	45oz-in (Digital)
Sail Winch Servo .....	388 oz-in
Transmitter.....	Spektrum DX2M 2.4GHz
Receiver .....	MR200 2.4GHz Spektrum marine
Hull material.....	Fiberglass Composite
Battery .....	4.8V 1300mAh Ni-MH
Charger (not included) .....	Spektrum™ 150mA Wall Charger (SPM9526)

## Table of Contents

Notice.....	2
Meaning of Special Language .....	2
Specifications.....	2
Table of Contents .....	3
Recommended Accessories .....	3
General Guidelines and Safety Precautions .....	3
Railing Installation.....	4
Installing the Ballast.....	6
Sail Installation.....	7
Rigging Guide .....	11
Charging the Receiver Battery.....	12
Transmitter Battery Installation and Checking the Controls .....	13
Sailing Tips.....	15
Warranty and Repair Policy .....	17
Compliance Information for the European Union.....	19
Replacement Parts.....	20

## Recommended Accessories

- #1 Phillips screwdriver (DYN2828)
- Thin CA (DYN5400)
- 30-minute epoxy (PAAPT39)
- Spektrum 150mA wall charger (SPM9526)

## General Guidelines and Safety Precautions

It is important that you read and follow this instruction manual, along with the radio system manual before you operate this exciting boat. Failure to read and understand the manual could result in personal injury, property damage or permanent damage to your boat. It is also important to run your boat responsibly. With proper care and maintenance, you will be able to proudly enjoy your model for many years to come.

When operating the boat, stay clear of people, full-scale boats, stationary objects and wildlife. It is preferable to operate the your model in low wake, low wind conditions and in areas free of people, wildlife and objects.

Check all of the hardware for damage and loose screws before and after each run.

If at any time while operating your model you sense any abnormal function, end your operation immediately. Do not operate your boat again until you are certain the problem has been corrected.

## Railing Installation

- 1. Take out the two-piece mast, main sail boom, boat stand, sails and hardware and so on. Put the hull on the boat stand.



- 2. Install the anchor with screws using screwdriver at the bow of the boat.

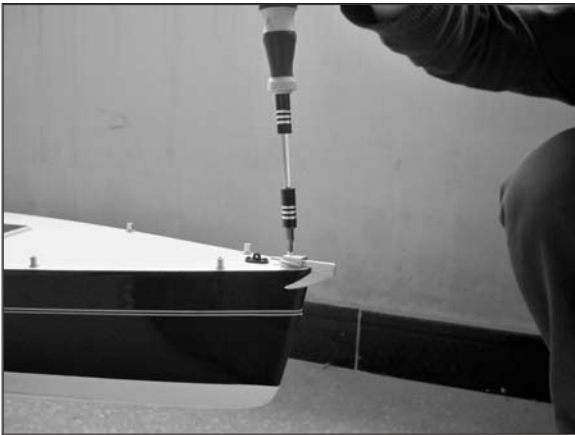

- 3. Locate the front railing and insert it into the railing stands.



- 4. Locate the stern railing and insert it into the railing stands.



- 5. Put the railing into the railing stand.



- 6. Insert the line into the hole of the railing.



- 7. Tie a knot with a line to fix the railing line and cut off the excess lines.

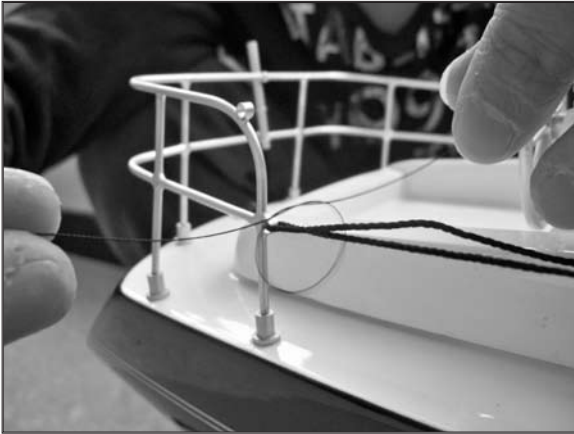

- 8. Repeat step 6 and 7 to finish all the railings and railing line installation.

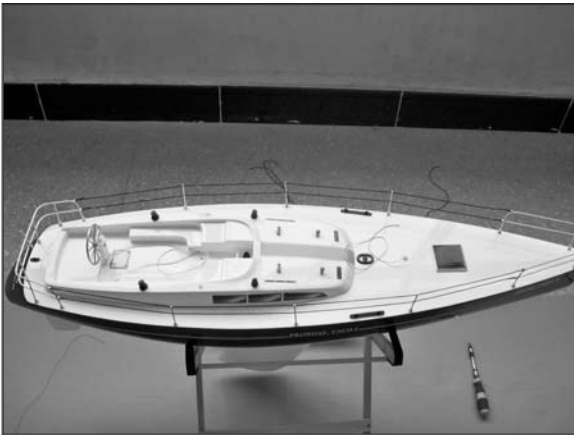

- 9. Apply a drop or two of thin CA to each of the points where the front railing fits into the railing stands on the hull.

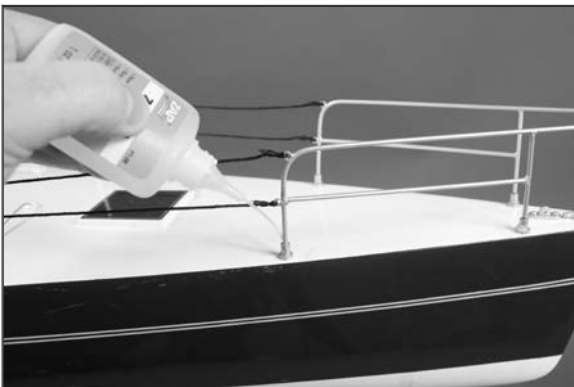

- 10. Apply a drop or two of thin CA to each of the points where the railing fits into the railing stands on the hull.



- 11. Apply a drop or two of thin CA to each of the points where the stern railing fits into the railing stands on the hull.



- 12. Apply a drop or two of thin CA to each of the knots of the line to prevent the knots from coming loose.

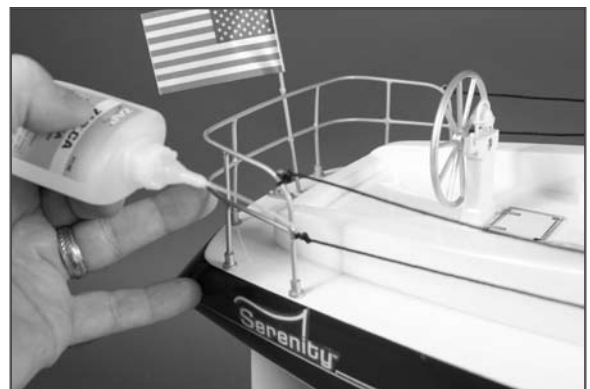

- 13. Guide the long antenna wire through the mounts on the stern railing. Slide the flag mast over the antenna.

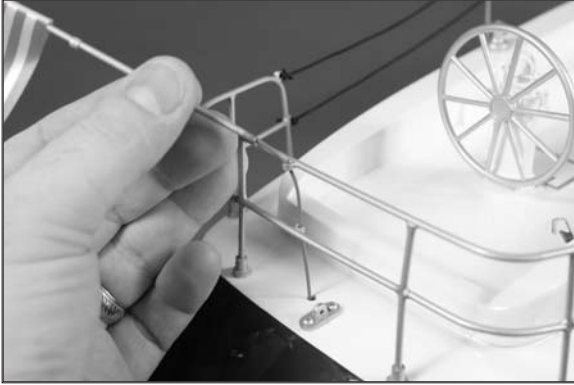

- 14. The flag mast is then inserted through the mounts and into the hull. Gently guide the antenna through and out the top of the flag mast.

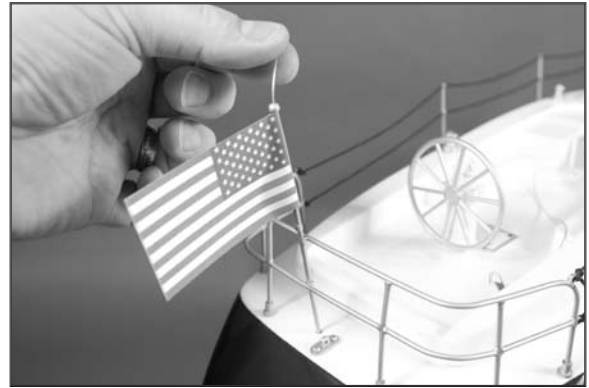

## Installing the Ballast

- 1. Remove the cover from the hull. The cover is held in position using magnets.



- 2. Remove the nylon bolt that secures the hatch cover to the hull.



- 3. Set the hatch cover aside. The cover cannot be fully removed as the line to the sail passes through the hatch cover.

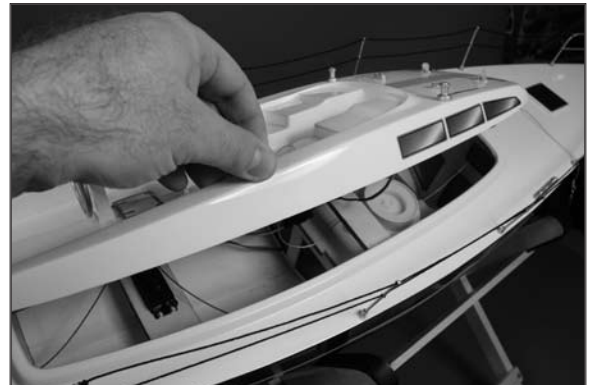

**Note:** The railing is fragile. Take care when removing the hatch and transporting the sailboat.

- 4. Pour the supplied ballast weight into the hull and into the keel of the boat. Use 30-minute epoxy to secure the weights in the keel. Use enough epoxy to cover the weights so they don't dislodge while operating the boat.

**Hint:** You can also use household paint to secure the weights in the keel. Pour enough paint into the keel to cover the weights and allow it to dry overnight.

## Sail Installation

- 1. Slide the upper and lower mast halves together.

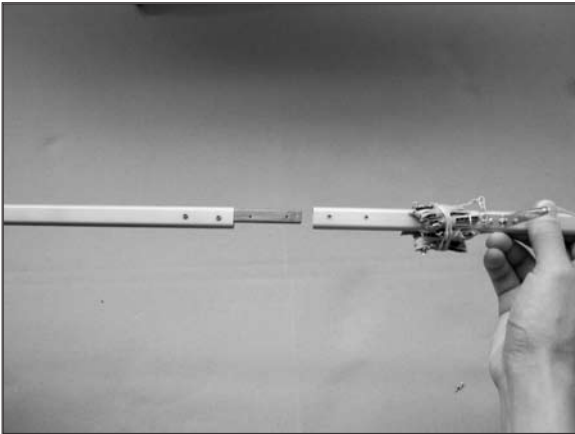

- 2. Join the two halves using four 2mm x 4mm screws.

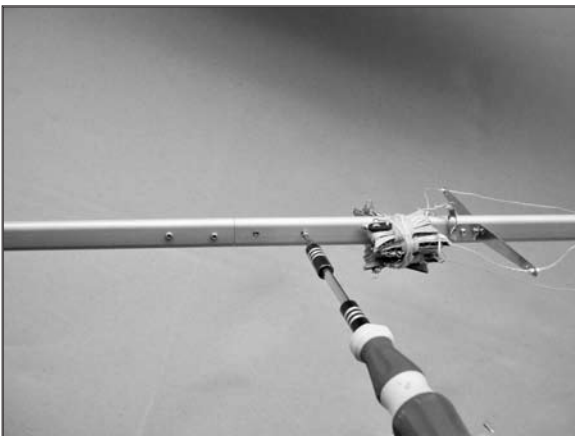

- 3. Locate the main sail boom and connect it to the main mast with a screw and nut.



- 4. Install the adjust support which connects the main mast and main sail boom.



- 5. Slide the mast assembly into the fitting on the top of the hull.



- 6. Remove the masthead crane and slide the unrolled main sail to the bottom of the mast.



- 7. Mount the masthead crane to the top of the mast.

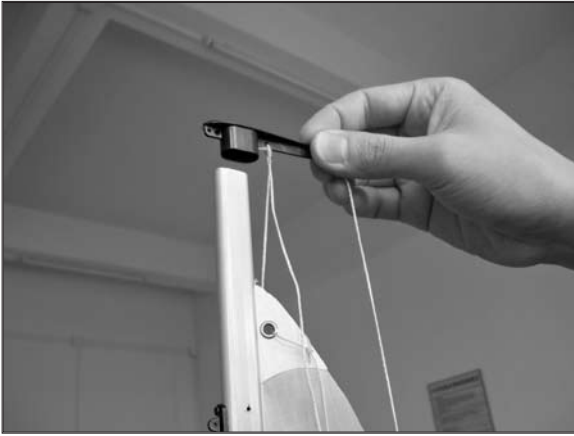

- 8. Please note the letter mark on the rolled lines.

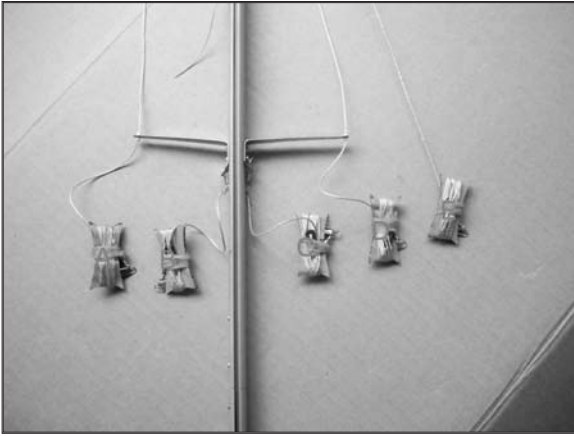

- 9. Please note the same letter mark with the lines on the deck.

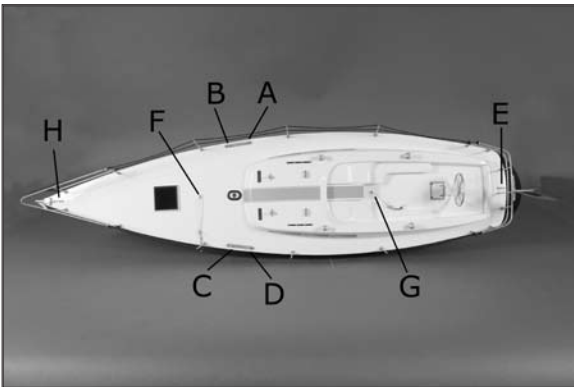

- 10. Open the rigging clip and attach it to the eye plate where the marked letter is the same as the letter on the according rigging, such as "C" to "C" as shown in the picture.



- 11. Pull up carefully on the jib stay to adjust the tension of the lines.

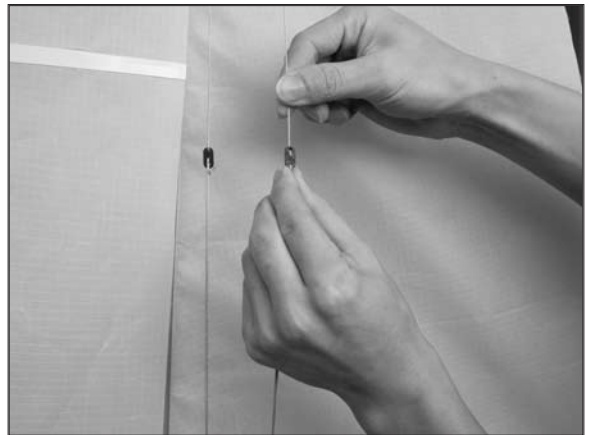

- 12. Pass the rigging line of the jib sail through the eye plate on the mast and then thread the line into the jib stay. Thread the line through the swivel and tie an overhand knot to the jib stay to secure. Connect "I" to "I" as shown in the picture.

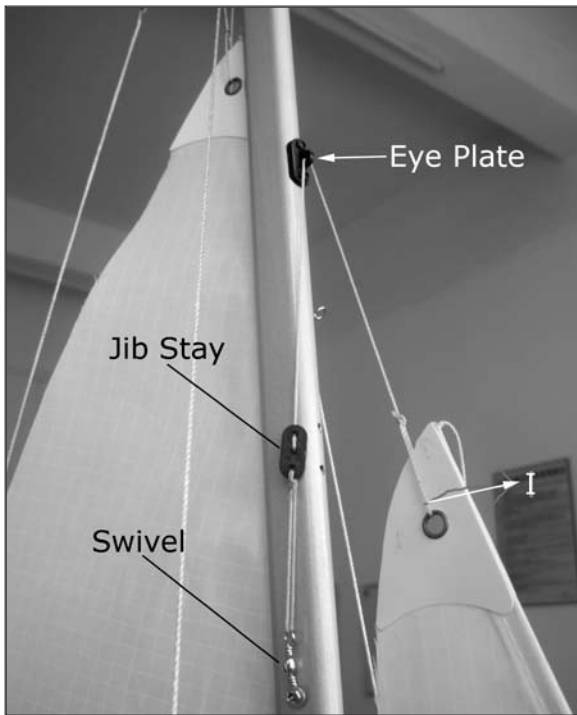

- 13. Thread the rigging lines of the top of the jib sail through the eye plate on the mast, round it on the cleat and secure it by tying a knot. Connect "K" to "K" as shown in the picture.

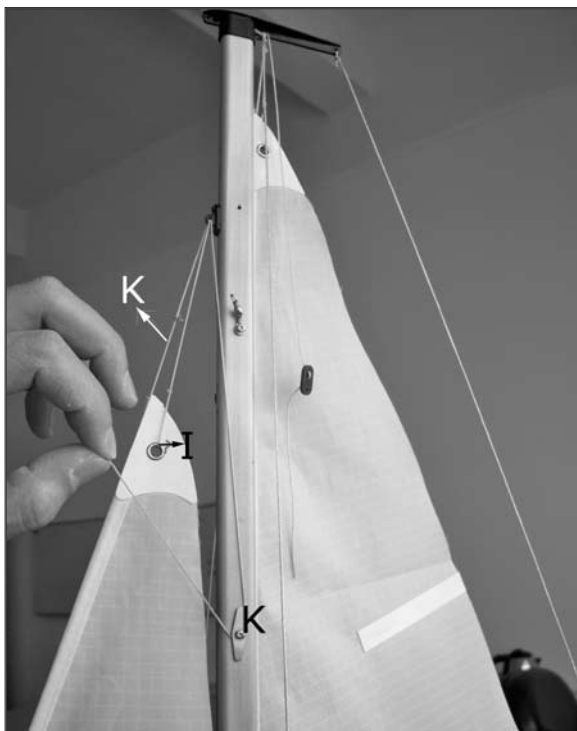

- 14. Pass the rigging line of the main sail through the hole of the masthead crane, thread the line through a jib stay and at last thread the line through the swivel, ending with tying a knot. Connect "J" to "J" as shown in the picture.

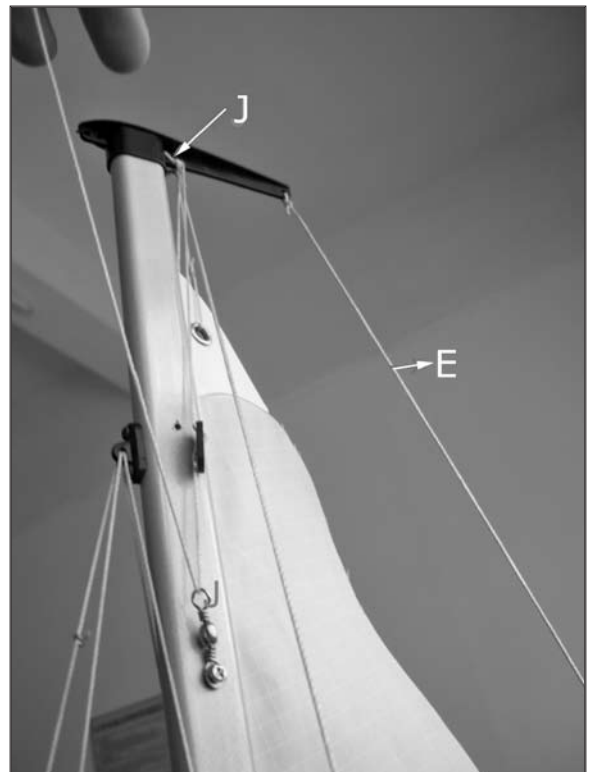

- 15. The finished installation of the rigging lines of the main sail.



- 16. Pull up the jib stay on the jib boom to adjust the tension of the lines.



- 17. Pull up the jib stay of the main boom to adjust the tension of the lines.



**Note:** Keep the main and jib boom lines loose until the radio is operational for adjustment.

- 18. The sailboat with installation finished.



**Note:** Adjust the lines so the mast is centered and perpendicular to the hull.

# Rigging Guide

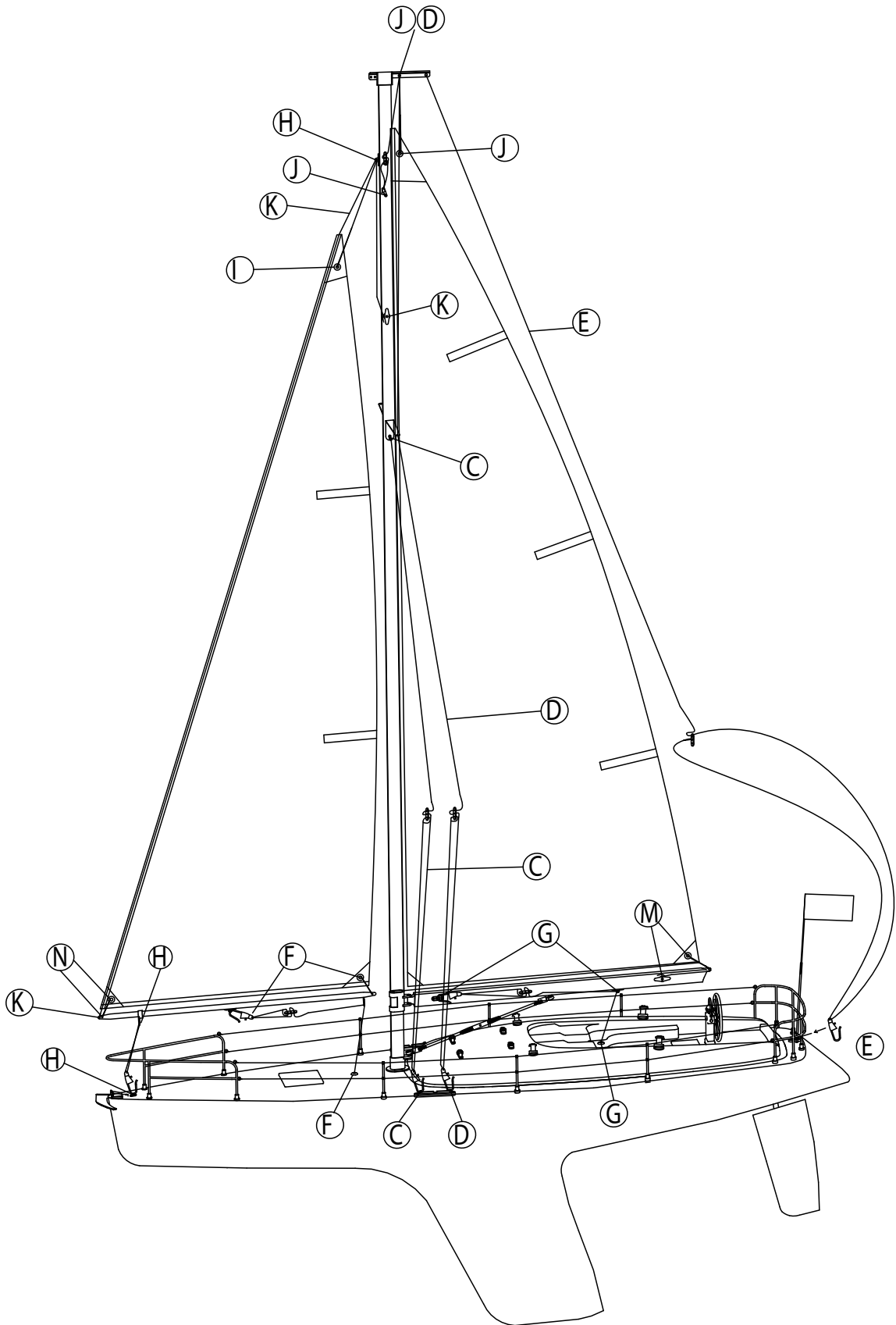

## Charging the Receiver Battery

- 1. Use a charger (we recommend the SPM9526 Spektrum 150mA wall charger) to charge the receiver battery. Allow 10–12 hours to fully charge the receiver battery when it is fully discharged.



- 2. Once the receiver battery is charged, place it in the boat.



- 3. Check the switch harness to make sure it is in the OFF position. Plug the receiver battery into the switch harness. Make sure to match the polarity of the plugs so the black and red wires align with each other.



- 4. Replace the hatch cover.

## Transmitter Battery Installation and Checking the Controls

- 1. Slide the battery cover off in the directions shown to access the battery compartment.



- 2. Install four AA-size batteries in the transmitter. Make sure to match the polarity of the batteries to the polarity molded into the battery compartment of the radio. Slide the cover back into position on the radio.



- 3. Slide the power switch on the transmitter to the ON position. Move the receiver switch to the ON position.



- 4. Move the stick on the transmitter to the right. The rear edge of the rudder will move to the right as shown. Actuate the STR (steering) reversing switch if the direction is reversed.

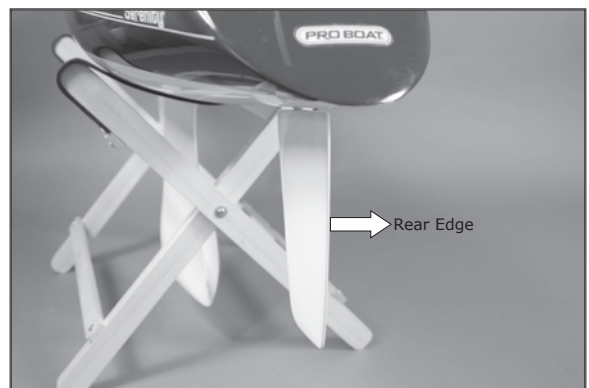

**Note:** If you find the boat is turning too quickly, you can reduce the amount of rudder by adjusting the dual rate knob on the top of the transmitter.



- 5. With the radio system on, move the left stick on your transmitter "up" and manually push the main sail and jib sail open. You should be able to open the sails to at least a 60-degree angle. If you cannot do this, it will be necessary to adjust the length of the line (allowing more slack) by adjusting the jib stays located underneath the main sail and jib sail booms.

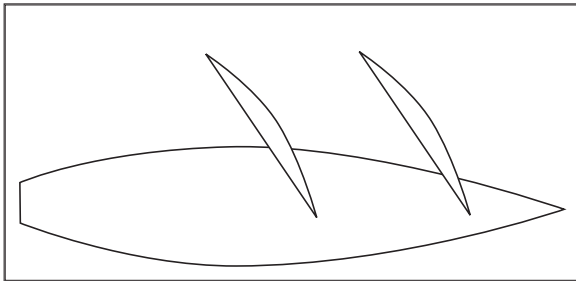

- 6. Move the left stick of your transmitter "down" to close the sails. The sails should close, with the jib sail being tighter than the main sail. There should be some slack left in the sail rigging when the sail gimbal moves the sails in.

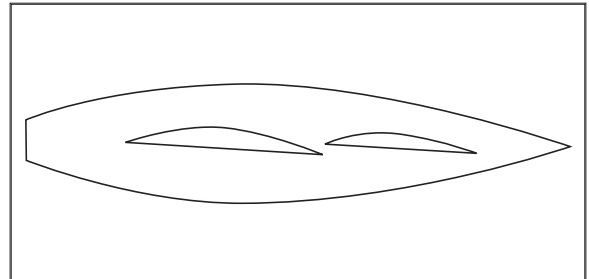

## Sailing Tips

After you have finished rigging the sails, it will be helpful to adjust the sails in order to optimize the performance of your boat. It is often necessary to briefly sail the Serenity in order to see how the sails need to be trimmed. Take your time to optimize your sailing pleasure.

- 1. Check to make sure the main boom and jib boom are in line with each other. Adjust the jib stay at the top of the jib sail to position the jib boom.



The following will help you get started in sailing. Follow the instructions and understand it takes some practice to become an accomplished yachtsman.

Do not sail if the winds are too strong. Best results will occur with winds between 5 and 12 mph.

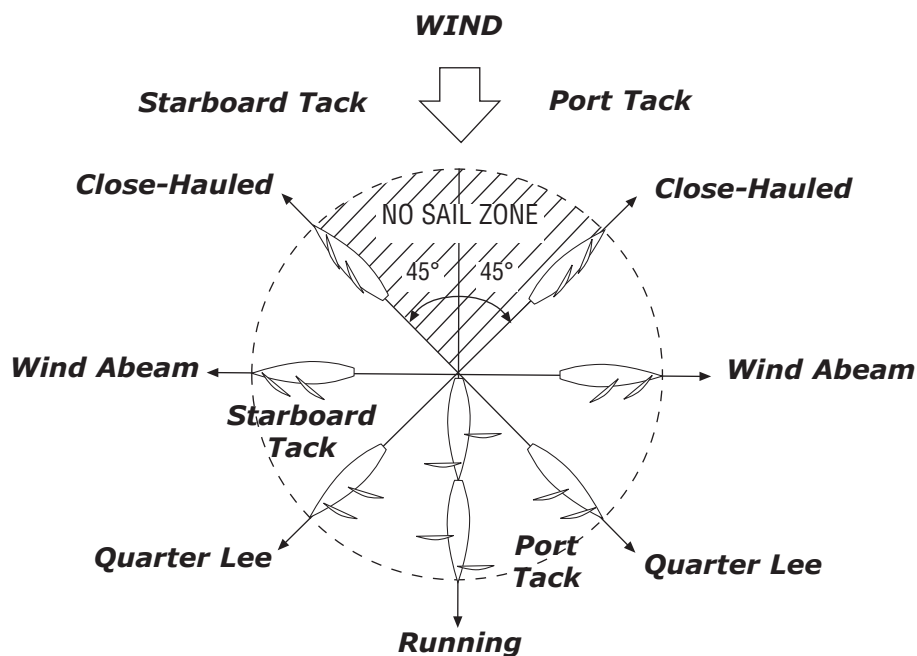

WIND



Wind Abeam  
Sails: Each at a position of 45°  
Rudder: In center position



STARBOARD TACK

Port Tack—Close-Hauled  
Sails: Keeping pulled in  
Rudder: To be held at the center as long as the sails do not shiver

Tacking  
Sails: Keeping pulled in  
Rudder: To the left

Bearing Away  
Sails: Let both out so as not to shiver  
Rudder: To the left

Tacking  
Sails: Keeping pulled in  
Rudder: To the left

Starboard Tack—Close-Hauled  
Sails: Keeping pulled in  
Rudder: To be held at the center as long as the sails do not shiver

Tacking  
Sails: Keeping pulled in  
Rudder: To the right

Port Tack—Close-Hauled  
Sails: Keeping pulled in  
Rudder: To be held at the center as long as the sails do not shiver

45°

Quarter Lee  
Sails: Letting both out a little more  
Rudder: To the left



Starboard Tack—Running  
Sails: Letting both out to their maximum position  
Rudder: In center position



Port Tack—Running  
Sails: Letting both out to their maximum position  
Rudder: In center position



Quarter Lee  
Sails: Pulling both in a little  
Rudder: In center position



Luffing Up  
Sails: Pulling in bit by bit  
Rudder: To the left



PORT TACK

START



Wind Abeam  
Sails: Each at a position of 45°  
Rudder: In center position

Luffing Up  
Sails: Pulling both in all the way  
Rudder: To the left

Sails Control

Rudder Control

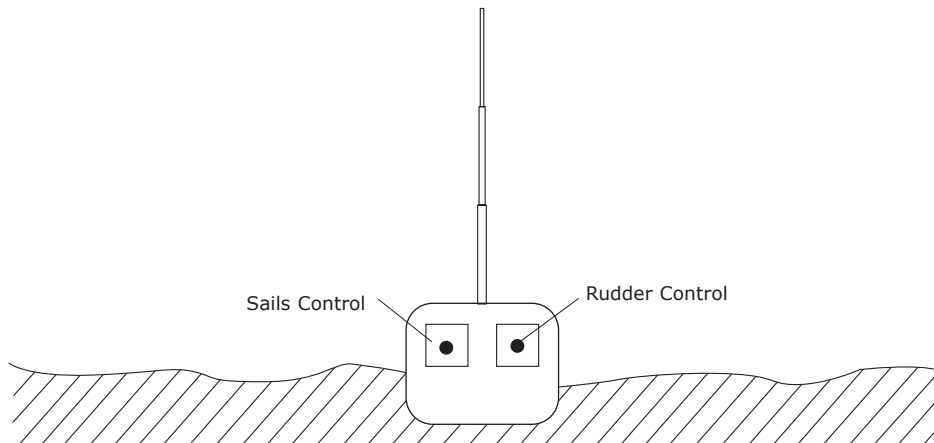

# Warranty and Repair Policy

## **Warranty Period**

---

Exclusive Warranty- Horizon Hobby, Inc., (Horizon) warrants that the Products purchased (the "Product") will be free from defects in materials and workmanship at the date of purchase by the Purchaser.

## **Limited Warranty**

---

**Horizon reserves the right to change or modify this warranty without notice and disclaims all other warranties, express or implied.**

(a) This warranty is limited to the original Purchaser ("Purchaser") and is not transferable. REPAIR OR REPLACEMENT AS PROVIDED UNDER THIS WARRANTY IS THE EXCLUSIVE REMEDY OF THE PURCHASER. This warranty covers only those Products purchased from an authorized Horizon dealer. Third party transactions are not covered by this warranty. Proof of purchase is required for all warranty claims.

(b) Limitations- HORIZON MAKES NO WARRANTY OR REPRESENTATION, EXPRESS OR IMPLIED, ABOUT NON-INFRINGEMENT, MERCHANTABILITY OR FITNESS FOR A PARTICULAR PURPOSE OF THE PRODUCT. THE PURCHASER ACKNOWLEDGES THAT THEY ALONE HAVE DETERMINED THAT THE PRODUCT WILL SUITABLY MEET THE REQUIREMENTS OF THE PURCHASER'S INTENDED USE.

(c) Purchaser Remedy- Horizon's sole obligation hereunder shall be that Horizon will, at its option, (i) repair or (ii) replace, any Product determined by Horizon to be defective. In the event of a defect, these are the Purchaser's exclusive remedies. Horizon reserves the right to inspect any and all equipment involved in a warranty claim. Repair or replacement decisions are at the sole discretion of Horizon. This warranty does not cover cosmetic damage or damage due to acts of God, accident, misuse, abuse, negligence, commercial use, or modification of or to any part of the Product. This warranty does not cover damage due to improper installation, operation, maintenance, or attempted repair by anyone other than Horizon. Return of any Product by Purchaser must be approved in writing by Horizon before shipment.

## **Damage Limits**

---

HORIZON SHALL NOT BE LIABLE FOR SPECIAL, INDIRECT OR CONSEQUENTIAL DAMAGES, LOSS OF PROFITS OR PRODUCTION OR COMMERCIAL LOSS IN ANY WAY CONNECTED WITH THE PRODUCT, WHETHER SUCH CLAIM IS BASED IN CONTRACT, WARRANTY, NEGLIGENCE, OR STRICT LIABILITY.

Further, in no event shall the liability of Horizon exceed the individual price of the Product on which liability is asserted. As Horizon has no control over use, setup, final assembly, modification or misuse, no liability shall be assumed nor accepted for any resulting damage or injury. By the act of use, setup or assembly, the user accepts all resulting liability. If you as the Purchaser or user are not prepared to accept the liability associated with the use of this Product, you are advised to return this Product immediately in new and unused condition to the place of purchase.

Law: These Terms are governed by Illinois law (without regard to conflict of law principals).

## **Warranty Services**

### ***Questions, Assistance, and Repairs***

---

Your local hobby store and/or place of purchase cannot provide warranty support or repair. Once assembly, setup or use of the Product has been started, you must contact Horizon directly. This will enable Horizon to better answer your questions and service you in the event that you may need any assistance. For questions or assistance, please direct your email to [productsupport@horizonhobby.com](mailto:productsupport@horizonhobby.com), or call 877.504.0233 toll free to speak to a Product Support representative. You may also find information on our website at [www.horizonhobby.com](http://www.horizonhobby.com).

### ***Inspection or Repairs***

---

If this Product needs to be inspected or repaired, please use the Horizon Online Repair Request submission process found on our website or call Horizon to obtain a Return Merchandise Authorization (RMA) number. Pack the Product securely using a shipping carton. Please note that original boxes may be included, but are not designed to withstand the rigors of shipping without additional protection. Ship via a carrier that provides tracking and insurance for lost or damaged parcels, as Horizon is not responsible for merchandise until it arrives and is accepted at our facility. An Online Repair Request is available at [www.horizonhobby.com](http://www.horizonhobby.com) <http://www.horizonhobby.com> under the Repairs tab. If you do not have internet access, please contact Horizon Product Support to obtain a RMA number along with instructions for submitting your product for repair. When calling Horizon, you will be asked to provide your complete name, street address, email address and phone number where you can be reached during business hours. When sending product into Horizon, please include your RMA number, a list

of the included items, and a brief summary of the problem. A copy of your original sales receipt must be included for warranty consideration. Be sure your name, address, and RMA number are clearly written on the outside of the shipping carton.

**Notice: Do not ship batteries to Horizon. If you have any issue with a battery, please contact the appropriate Horizon Product Support office.**

### **Warranty Inspection and Repairs**

**To receive warranty service, you must include your original sales receipt** verifying the proof-of-purchase date. Provided warranty conditions have been met, your Product will be repaired or replaced free of charge. Repair or replacement decisions are at the sole discretion of Horizon.

### **Non-Warranty Repairs**

**Should your repair not be covered by warranty the repair will be completed and payment will be required without notification or estimate of the expense unless the expense exceeds 50% of the retail purchase cost.** By submitting the item for repair you are agreeing to payment of the repair without notification. Repair estimates are available upon request. You must include this request with your repair. Non-warranty repair estimates will be billed a minimum of ½ hour of labor. In addition you will be billed for return freight. Horizon accepts money orders and cashiers checks, as well as Visa, MasterCard, American Express, and Discover cards. By submitting any item to Horizon for inspection or repair, you are agreeing to Horizon’s Terms and Conditions found on our website under the Repairs tab.

### **Warranty and Service Contact Information**

Country of Purchase	Horizon Hobby	Address	Phone Number/Email Address
United States of America	Horizon Service Center (Electronics and engines)	4105 Fieldstone Rd Champaign, Illinois 61822 USA	877-504-0233 Online Repair Request visit: www.horizonhobby.com/repairs
	Horizon Product Support (All other products)	4105 Fieldstone Rd Champaign, Illinois 61822 USA	877-504-0233 productsupport@horizonhobby.com
United Kingdom	Horizon Hobby Limited	Units 1-4 Ployters Rd Staple Tye Harlow, Essex CM18 7NS United Kingdom	+44 (0) 1279 641 097 sales@horizonhobby.co.uk
Germany	Horizon Technischer Service	Hamburger Str. 10 25335 Elmshorn Germany	+49 4121 46199 66 service@horizonhobby.de
France	Horizon Hobby SAS	14 Rue Gustave Eiffel Zone d'Activité du Réveil Matin 91230 Montgeron	+33 (0) 1 60 47 44 70 infofrance@horizonhobby.com

### **Customer Service Information**

Country of Purchase	Horizon Hobby	Address	Phone Number/Email Address
United States	Sales	4105 Fieldstone Rd Champaign, Illinois 61822 USA	(800) 338-4639 sales@horizonhobby.com
United Kingdom	Horizon Hobby Limited	Units 1-4 Ployters Rd Staple Tye Harlow, Essex CM18 7NS United Kingdom	+44 (0) 1279 641 097 sales@horizonhobby.co.uk
Germany	Horizon Hobby GmbH	Hamburger Str. 10 25335 Elmshorn Germany	+49 4121 46199 60 service@horizonhobby.de
France	Horizon Hobby SAS	14 Rue Gustave Eiffel Zone d'Activité du Réveil Matin 91230 Montgeron	+33 (0) 1 60 47 44 70 infofrance@horizonhobby.com

# Regulatory Information

## FCC Information

This device complies with part 15 of the FCC rules. Operation is subject to the following two conditions: (1) This device may not cause harmful interference, and (2) this device must accept any interference received, including interference that may cause undesired operation. Caution: Changes or modifications not expressly approved by the party responsible for compliance could void the user's authority to operate the equipment. This product contains a radio transmitter with wireless technology which has been tested and found to be compliant with the applicable regulations governing a radio transmitter in the 2.400GHz to 2.4835GHz frequency range.

### Antenna Separation Distance

When operating your transmitter, please be sure to maintain a separation distance of at least 5 cm between your body (excluding fingers, hands, wrists, ankles and feet) and the antenna to meet RF exposure safety requirements as determined by FCC regulations. The illustrations below show the approximate 5 cm RF exposure area and typical hand placement when operating your transmitter.

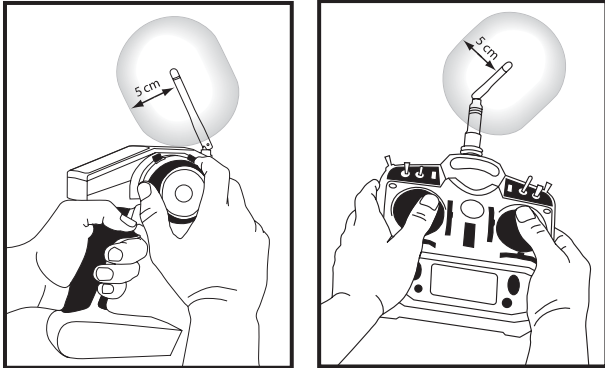

## Compliance Information for the European Union

AT	BG	CY	CZ	DE
DK	ES	FI	FR	GR
HU	IE	IT	LT	LU
LV	MT	NL	PL	PT
RO	SE	SI	SK	UK

## CE DECLARATION OF CONFORMITY

(in accordance with ISO/IEC 17050-1)

No. HH2011030701

Product(s): PRB Serenity 1 Meter Sailboat RTR  
Item Number(s): PRB3450

Equipment class: 2

The object of declaration described above is in conformity with the requirements of the specifications listed below, following the provisions of the European R&TTE directive 1999/5/EC:

EN 300-328 V1.7.1  
EN 301 489-1 V1.7.1: 2006  
EN 301 489-17 V1.3.2: 2008  
EN 60950-1:2006+A11

Signed for and on behalf of:  
Horizon Hobby, Inc.  
Champaign, IL USA  
March 7, 2011

Steven A. Hall

Vice President  
International Operations and Risk Management  
Horizon Hobby, Inc.



### INSTRUCTIONS FOR DISPOSAL OF WEEE BY USERS IN THE EUROPEAN UNION

This product must not be disposed of with other waste. Instead, it is the user's responsibility to dispose of their waste equipment by handing it over to a designated collection point for the recycling of waste electrical and electronic equipment. The separate collection and recycling of your waste equipment at the time of disposal will help to conserve natural resources and ensure that it is recycled in a manner that protects human health and the environment. For more information about where you can drop off your waste equipment for recycling, please contact your local city office, your household waste disposal service or where you purchased the product.



## Replacement Parts

PRB3451	Hull	PRB3467	Railing (Front)
PRB3452	Switch Cover and Nut	PRB3468	Railing (Rear)
PRB3453	Capstan (4 pc)	PRB3469	Mast
PRB3454	Pulley Sets	PRB3470	Boom (Front and Rear)
PRB3455	Railing Stand (16 pc)	PRB3471	Boom Turnbuckle
PRB3456	Jack Stays (4 pc)	PRB3472	Spreader
PRB3457	Steering Wheel Set	PRB3473	Jib Stay (7 pc)
PRB3458	Rudder with Arm	PRB3474	Snaps (10 pc)
PRB3459	Anchor	PRB3475	Main Sail
PRB3460	Balloon with Strap	PRB3476	Jib Sail
PRB3461	Rigging Line	PRB3477	Boat Stand
PRB3462	Railing Line	PRB3478	4.8V Ni-MH Battery
PRB3463	Winch Retaining Ring	PRB3479	Switch Harness
PRB3464	Ballast	PRB3480	Sail Winch Servo
PRB3465	Hatch	SPMMR200	Receiver
PRB3466	Railing Post (6 pc)	SPMR2200	Transmitter



© 2011 Horizon Hobby, Inc.  
horizonhobby.com  
www.proboatmodels.com

*The Spektrum trademark is used with permission of Bachmann Industries, Inc.*

*All other marks are trademarks or registered trademarks of Horizon Hobby, Inc.*